

Celle® Chairs

Prices effective December 7, 2009
Published February 2010

Introduction	page 2
Celle® Chairs	3
Work Chair	5
Accessories	9
Appendices	
To view and/or print price book appendices, select the appropriate price book from www.HermanMiller.com .	

Introduction

A Note on the Organization of This Book

There are a few signals that will help you understand the organization of this book. Once you know them, you should be able to find your way around easily.

Like a newspaper, this book is formatted with columns of text and illustrations that run vertically.

Information wraps from one column to the next and continues for as many pages as it needs to.

Black bars are clues.

A black bar at the top of a page signals the start of information about a product.

This information is divided into two sections, each signaled by a black bar. Product Information includes a description, additional notes, and dimensional drawings. Specification Information, which always begins at the top of a column, includes a series of steps. Each step represents a decision you need to make in order to complete your product number. Steps must be followed sequentially. The number of pages needed to complete information on a product varies; some will be complete in one page; others may fill three or four pages. Just continue going through the steps until you run into the next product, signaled by the black bar at the top of the page.

Black tabs running along the outside edge of the page help you locate what section you are in or what section you want to go to. You can thumb forwards or backwards to find a section; tabs and text appear on both sides of the page.

The additional pages in the back of the book include the appendices and indices. They are signaled by a long black bar running along the outside edge of the page.

The index is presented two ways.

The first index is in alphabetical order by product name. It can be helpful if you are new to the products and numbering scheme or if you are looking for a type of product, such as work chair or round table.

The second index is by product number. It lists, in alphanumeric order, the base product number, typically a five-digit number.

General Information

This book is effective December 7, 2009, subject to change without notice. Products may be purchased from authorized Herman Miller dealers who will quote prices upon request. For more information about our products and services or to see a list of dealers, visit www.HermanMiller.com.

All prices are list prices. Additional services, such as planning services, design, storage, and installation, are not included and must be added to these prices when the additional services are requested.

Illustrations, specifications, and prices are based on the latest information at the time of publication. The right is reserved to make changes at any time without notice in prices, fabrics, finishes, materials, specifications, and models, and also to discontinue models and finishes.

Dimensions shown in the drawings are engineering drawing dimensions rounded up to the nearest $\frac{1}{8}$ ". Product is shipped set up or knocked down. Products that include "Shipped knocked down" in the description require some assembly. If this statement does not appear in the description, the product is shipped assembled.

Service problems are normally handled by a Herman Miller authorized dealer. Where this cannot be accomplished on a local level, service problems should be referred to the Customer Care Representative for your region, Herman Miller, Inc., Zeeland, Michigan 49464.

20-Day or Less/Assigned Lead-Time Shipments

All products and options in this price book not designated by an Assigned Program icon  will ship in **20 business days or less** after being acknowledged by Herman Miller.

Products and options designated by an  are on the assigned lead-time program and may ship in 20 days, less than 20 days, or more than 20 days from order acknowledgement.

Work Chair

Accessories

Work Chair

- CJ111
- CJ112
- CJ113
- CJ121
- CJ122
- CJ123
- CJ131
- CJ132
- CJ133



Product Information

Description

This chair has a Cellular Suspension™ seat and back material that is lightweight and breathable. The material evenly distributes the user's weight over the seat and allows the back to provide flexible and continuous support. The Harmonic™ tilt provides continuous balance and lets the body recline naturally, pivoting at the ankles, knees, and hips. The chair has a 5-star base and 3 height-adjustment options: the low-height option has a seat-height range of 15" to 19"; the standard-height option has a seat-height range of 15 1/2" to 20 1/4"; the high-height option has a seat-height range of 16 1/2" to 21 1/4".

Tilt options include a standard tilt, tilt limiter, and tilt limiter and seat angle. The tilt limiter allows the user to set the tilt range to limit the amount of recline. The tilt limiter and seat angle allows the user to select the tilt range and either a horizontal or 5° forward seat angle.

Back options include a standard version and a user-adjustable lumbar support version. The adjustable lumbar support adjusts 4" in height and 1" in depth. Both back options include passive PostureFit® at the base of the back, below the beltline, that helps achieve healthier posture and improved lower back comfort.

Upholstered options include an upholstered contoured foam cushion seat with a Cellular Suspension™ back or upholstered back, and a smooth upholstered seat pad with a Cellular Suspension back or upholstered back.

Seat options include a 15 1/2" fixed seat depth or an adjustable seat depth that adjusts from 15 1/2" to 18".

Arm choices include no arms, fixed arms, or 3-dimensional adjustable arms. Each arm adjusts 4" vertically and 1" horizontally. Armpads pivot 11° outward and 11° inward.

A fire-retardant chair meets CAL 133 requirements. The chair's seat assembly, back, tilt covers, and upholstered seat and back pads are manufactured with a fire-retardant additive. The additive does not meet Herman Miller's Design for the Environment criteria.

Notes

Chair is tested and warranted for use by persons 300 pounds and under. For information on casters and glides, see Casters and Glides in Appendices.

Customer's Own Material (COM) for upholstered cushion seat requires the following:

Seat option—COM

UC—.81 yards

Dimensions

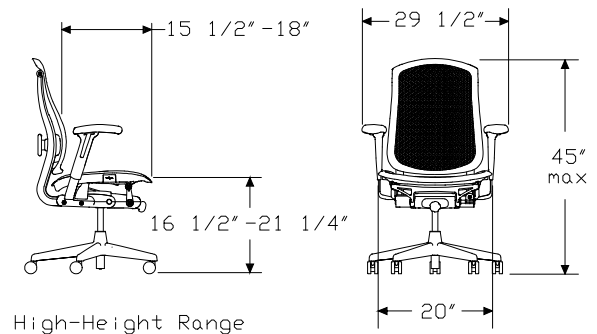
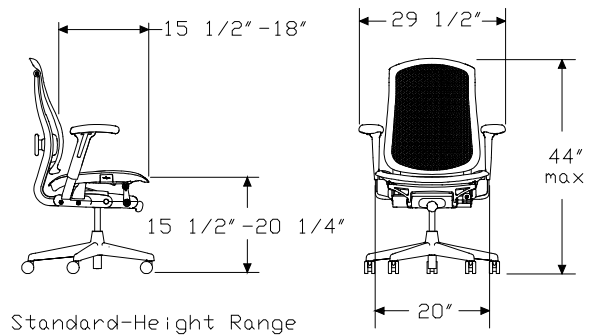
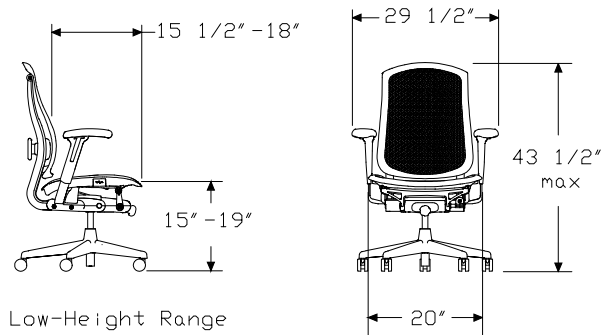

Specification Information

Step 1.

CJ1

Step 2. Height Adjustment

- 1** low-height range
- 2** standard-height range
- 3** high-height range

Step 3. Tilt

- 1** standard tilt
- 2** tilt limiter
- 3** tilt limiter and seat angle

Step 4. Arms

- N** no arms
- P** fixed arms
- A** adjustable arms

Step 5. Seat-Depth Adjustment

- F** fixed seat depth
- A** adjustable seat depth

Step 6. Seat Material

- CC** Cellular Suspension™ seat and back
- SC** smooth upholstered seat, Cellular Suspension™ back
- UC** upholstered cushion seat, Cellular Suspension™ back
- SF** smooth upholstered seat, upholstered back
- UF** upholstered cushion seat, upholstered back

Step 7. Fire Retardancy

For not fire retardant (), skip this step.*

- FR** fire retardant A

Prices for Steps 1-7.

			CC*	CCFR	SC*	SCFR	UC*	UCFR	SF*
CJ111	N	F	\$564	624	584	644	584	644	634
		A	\$614	674	634	694	634	694	684
	P	F	\$624	684	644	704	644	704	694
		A	\$674	734	694	754	694	754	744
	A	F	\$694	754	714	774	714	774	764
		A	\$744	804	764	824	764	824	814
CJ112	N	F	\$594	654	614	674	614	674	664
		A	\$644	704	664	724	664	724	714
	P	F	\$654	714	674	734	674	734	724
		A	\$704	764	724	784	724	784	774
	A	F	\$724	784	744	804	744	804	794
		A	\$774	834	794	854	794	854	844

	A	F	\$724	784	744	804	744	804	794
		A	\$774	834	794	854	794	854	844

CJ113	N	F	\$629	689	649	709	649	709	699
		A	\$679	739	699	759	699	759	749

	P	F	\$689	749	709	769	709	769	759
		A	\$739	799	759	819	759	819	809

	A	F	\$759	819	779	839	779	839	829
		A	\$809	869	829	889	829	889	879

CJ121	N	F	\$564	624	584	644	584	644	634
		A	\$614	674	634	694	634	694	684

	P	F	\$624	684	644	704	644	704	694
		A	\$674	734	694	754	694	754	744

	A	F	\$694	754	714	774	714	774	764
		A	\$744	804	764	824	764	824	814

CJ122	N	F	\$594	654	614	674	614	674	664
		A	\$644	704	664	724	664	724	714

	P	F	\$654	714	674	734	674	734	724
		A	\$704	764	724	784	724	784	774

	A	F	\$724	784	744	804	744	804	794
		A	\$774	834	794	854	794	854	844

CJ123	N	F	\$629	689	649	709	649	709	699
		A	\$679	739	699	759	699	759	749

	P	F	\$689	749	709	769	709	769	759
		A	\$739	799	759	819	759	819	809

	A	F	\$759	819	779	839	779	839	829
		A	\$809	869	829	889	829	889	879

CJ131	N	F	\$604	664	624	684	624	684	674
		A	\$654	714	674	734	674	734	724

	P	F	\$664	724	684	744	684	744	734
		A	\$714	774	734	794	734	794	784

	A	F	\$734	794	754	814	754	814	804
		A	\$784	844	804	864	804	864	854

CJ132	N	F	\$634	694	654	714	654	714	704
		A	\$684	744	704	764	704	764	754

	P	F	\$694	754	714	774	714	774	764
		A	\$744	804	764	824	764	824	814

	A	F	\$764	824	784	844	784	844	834
		A	\$814	874	834	894	834	894	884

CJ133	N	F	\$669	729	689	749	689	749	739
		A	\$719	779	739	799	739	799	789

	P	F	\$729	789	749	809	749	809	799
		A	\$779	839	799	859	799	859	849
	A	F	\$799	859	819	879	819	879	869
		A	\$849	909	869	929	869	929	919
						SFFR	UF*	UFFR	
CJ111	N	F				\$694	634	694	
		A				\$744	684	744	
	P	F				\$754	694	754	
		A				\$804	744	804	
	A	F				\$824	764	824	
		A				\$874	814	874	
CJ112	N	F				\$724	664	724	
		A				\$774	714	774	
	P	F				\$784	724	784	
		A				\$834	774	834	
	A	F				\$854	794	854	
		A				\$904	844	904	
CJ113	N	F				\$759	699	759	
		A				\$809	749	809	
	P	F				\$819	759	819	
		A				\$869	809	869	
	A	F				\$889	829	889	
		A				\$939	879	939	
CJ121	N	F				\$694	634	694	
		A				\$744	684	744	
	P	F				\$754	694	754	
		A				\$804	744	804	
	A	F				\$824	764	824	
		A				\$874	814	874	
CJ122	N	F				\$724	664	724	
		A				\$774	714	774	
	P	F				\$784	724	784	
		A				\$834	774	834	
	A	F				\$854	794	854	
		A				\$904	844	904	
CJ123	N	F				\$759	699	759	
		A				\$809	749	809	
	P	F				\$819	759	819	
		A				\$869	809	869	
	A	F				\$889	829	889	
		A				\$939	879	939	

CJ131	N	F	\$734	674	734
		A	\$784	724	784
	P	F	\$794	734	794
		A	\$844	784	844
	A	F	\$864	804	864
		A	\$914	854	914
CJ132	N	F	\$764	704	764
		A	\$814	754	814
	P	F	\$824	764	824
		A	\$874	814	874
	A	F	\$894	834	894
		A	\$944	884	944
CJ133	N	F	\$799	739	799
		A	\$849	789	849
	P	F	\$859	799	859
		A	\$909	849	909
	A	F	\$929	869	929
		A	\$979	919	979
Step 8. Back Support Option					
N2	no additional support				+\$0
AJ	adjustable lumbar support				+\$45
Step 9. Base/Frame Finish					
3G	brownstone				+\$0
G1	graphite				+\$0
Step 10. Casters/Glides					
BB	2 1/2" hard caster, black yoke, carpet				+\$0
GF	2 1/2" glide, hard floors or carpet				+\$0
C7	2 1/2" caster, black yoke, hard floors or carpet				+\$40
C9	2 1/2" braking caster, black yoke, hard floors or carpet				+\$40
Step 11. Seat Finish					
<i>For Cellular Suspension™ seat and back (CC), smooth upholstered seat, Cellular Suspension™ back (SC), or smooth upholstered seat, upholstered back (SF) with not fire retardant</i>					
3G	brownstone				+\$0
DM	champagne				+\$0
G1	graphite				+\$0
XG	cabernet				+\$0
ZN	blue fog				+\$0
91	white				+\$10

For Cellular Suspension™ seat and back (CC), smooth upholstered seat, Cellular Suspension™ back (SC), or smooth upholstered seat, upholstered back (SF) with fire retardant (FR)

DM	champagne A	+\$0
G1	graphite A	+\$0

Step 12. Back Finish

For not fire retardant

3G	brownstone	+\$0
DM	champagne	+\$0
G1	graphite	+\$0
XG	cabernet	+\$0
ZN	blue fog	+\$0
91	white	+\$10

For fire retardant (FR)

DM	champagne A	+\$0
G1	graphite A	+\$0

Step 13. Armpad Finish

For fixed arms (P) or adjustable arms (A)

3G	brownstone	+\$0
BK	black	+\$0

Step 14. Fabric Seat

See application chart and textiles list for material usage and numbers. First 2 digits of number indicate material; remaining 2 digits indicate color.

For smooth upholstered seat, Cellular Suspension™ back (SC), smooth upholstered seat, upholstered back (SF), or upholstered cushion seat, upholstered back (UF)

Price Category 3	+\$20
------------------	-------

For upholstered cushion seat, Cellular Suspension™ back (UC) with not fire retardant

Price Category 1	+\$0
Price Category 2	+\$10
Price Category 3	+\$20
Price Category 4	+\$35
Price Category 9	+\$265
Price Category B	+\$40
Price Category E	+\$90
Price Category F	+\$112
Price Category G	+\$160
Price Category H	+\$200

For upholstered cushion seat, Cellular Suspension™ back (UC) with fire retardant (FR)

Price Category 1	+\$0
Price Category 2	+\$10
Price Category 3	+\$20
Price Category 4	+\$35
Price Category 9	+\$265

Step 15. Fabric Back

See application chart and textiles list for material usage and numbers. First 2 digits of number indicate material; remaining 2 digits indicate color.

For smooth upholstered seat, upholstered back (SF) or upholstered cushion seat, upholstered back (UF)

Price Category 3	+\$40
------------------	-------

For upholstered cushion seat, upholstered back (UF) with not fire retardant

Price Category 1	+\$0
Price Category 2	+\$20
Price Category 3	+\$40

Arm Kit

CJ900

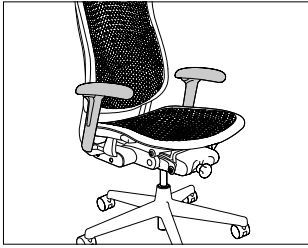

Product Information

Description

These arms retrofit to a Celle® work chair. They adjust 4" vertically, 1" horizontally, and pivot the armpads 11° outward and 11° inward.

Specification Information

Step 1.

CJ900A \$130

Step 2. Frame Finish

3G brownstone +\$0

G1 graphite +\$0

Step 3. Armpad Finish

3G brownstone +\$0

BK black +\$0

Celle® Accessories

For more information about our products and services or to see a list of dealers, please visit us at www.HermanMiller.com or call (800) 851 1196.

This book is recyclable. Printed in U.S.A. on recycled paper.

© 2010 Herman Miller, Inc., Zeeland, Michigan

© HermanMiller, , Abak, Action Office, Aeron, Ambi, Ardea, Aside, Avive, Babble, C2, Caper, Celle, Co/Struc, DOT, Eames, Embody, Equa 2, Ergon 3, Ethospace, Fine-Tune, FlexFront, Formcoat, Ground Cloth, Herman Miller for Healthcare, Herman Miller Options, Intersect, Kinemat, Leaf, Lifework, Limerick, Meridian, Mirra, Passage, Pedastool, Pellicle, Perspectives, PostureFit, Prospects, Quadrant, Reaction, Resolve, RoomTune, Scooter, Stoa, Teneo, V-Wall, Vary Easy, Vivo, and Z-Axis are among the registered trademarks of Herman Miller, Inc., and its owned subsidiaries.

TM About Face, AireWeave, Airia, Arrio, Backfit, Boomerang, Bubbletack, Burdick Group, Celeste, Cellular Suspension, CLT, CoActive, Cognita, Compass, Cygnus, Enchord, EnhancedAccess, E-Wall, Flex-Edge, Flute, Harmonic, Herman Miller for the Home, Herman Miller International Collection, Herman Miller Select, Hopsak 2, Intent, Iota, Keyless Entry, Latitude, Lyris, Multiscrim, My Studio Environments, Nelson, Pixelated Support, Programmable Environments, Q, Rapunzel, Recline Selector, Sense, Setu, Stackable, Stackable Storage, The Be Collection, Thinking is good for you, TriFlex, Tu, and Twist are among the trademarks of Herman Miller, Inc., and its owned subsidiaries.

SM TAP, Textile Alliance Program and Thoughtpile are among the service marks of Herman Miller, Inc.

Chemsurf is a registered trademark of Wilsonart International.

Corian is a registered trademark of DuPont.

FLEXNET is a trademark of Milliken & Co.

Floor Saver GlideTM is a trademark of Carpin Manufacturing Inc.

Geiger is a registered trademark of Geiger International.

Goetz is a trademark of Mark W. Goetz.

Hang-It-All is a registered trademark of Lucia Eames Demetrios, d.b.a. Eames Office.

Holophane is a registered trademark of Holophane.

Ingeo is a trademark of Cargill Dow LLC.

Microsoft and Natural Keyboard are registered trademarks of Microsoft Corporation.

Noguchi[®] is a registered trademark of The Isamu Noguchi Foundation and Garden Museum.

Qt Quiet technology and Qt are trademarks of Cambridge Sound Management, Inc.