

Ergon 3[®] Chairs

Prices effective December 7, 2009

Introduction	page 2
Ergon 3[®] Chairs	3
Work Chair	5
Accessories	8
Appendices	
To view and/or print price book appendices, select the appropriate price book from www.HermanMiller.com .	



Introduction

A Note on the Organization of This Book

There are a few signals that will help you understand the organization of this book. Once you know them, you should be able to find your way around easily.

Like a newspaper, this book is formatted with columns of text and illustrations that run vertically.

Information wraps from one column to the next and continues for as many pages as it needs to.

Black bars are clues.

A black bar at the top of a page signals the start of information about a product.

This information is divided into two sections, each signaled by a black bar. Product Information includes a description, additional notes, and dimensional drawings. Specification Information, which always begins at the top of a column, includes a series of steps. Each step represents a decision you need to make in order to complete your product number. Steps must be followed sequentially. The number of pages needed to complete information on a product varies; some will be complete in one page; others may fill three or four pages. Just continue going through the steps until you run into the next product, signaled by the black bar at the top of the page.

Black tabs running along the outside edge of the page help you locate what section you are in or what section you want to go to. You can thumb forwards or backwards to find a section; tabs and text appear on both sides of the page.

The additional pages in the back of the book include the appendices and indices. They are signaled by a long black bar running along the outside edge of the page.

The index is presented two ways.

The first index is in alphabetical order by product name. It can be helpful if you are new to the products and numbering scheme or if you are looking for a type of product, such as work chair or round table.

The second index is by product number. It lists, in alphanumeric order, the base product number, typically a five-digit number.

General Information

This book is effective December 7, 2009, subject to change without notice. Products may be purchased from authorized Herman Miller dealers who will quote prices upon request. For more information about our products and services or to see a list of dealers, visit www.HermanMiller.com.

All prices are list prices. Additional services, such as planning services, design, storage, and installation, are not included and must be added to these prices when the additional services are requested.

Illustrations, specifications, and prices are based on the latest information at the time of publication. The right is reserved to make changes at any time without notice in prices, fabrics, finishes, materials, specifications, and models, and also to discontinue models and finishes.

Dimensions shown in the drawings are engineering drawing dimensions rounded up to the nearest $\frac{1}{8}$ ". Product is shipped set up or knocked down. Products that include "Shipped knocked down" in the description require some assembly. If this statement does not appear in the description, the product is shipped assembled.

Service problems are normally handled by a Herman Miller authorized dealer. Where this cannot be accomplished on a local level, service problems should be referred to the Customer Care Representative for your region, Herman Miller, Inc., Zeeland, Michigan 49464.

20-Day or Less/Assigned Lead-Time Shipments

All products and options in this price book not designated by an Assigned Program icon  will ship in **20 business days or less** after being acknowledged by Herman Miller.

Products and options designated by an  are on the assigned lead-time program and may ship in 20 days, less than 20 days, or more than 20 days from order acknowledgement.

Work Chair

Accessories

Work Chair

EE122
EE123

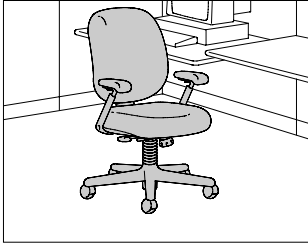

Product Information

Description

This chair is available in 3 sizes and has deeply contoured seat and back cushions with thick foam padding. It has a 5-star base, pneumatic seat-height adjustment, and back-height adjustment. All chair sizes have high backs; size B is also available in a mid-back.

Tilt options include a knee-tilt swivel that allows the user to lock the seat angle in a horizontal position, or a knee-tilt swivel with forward angle that allows the user to select a horizontal or 5° forward seat angle; the seat angle can be locked in either position.

Back options include a nonadjustable back angle, or an adjustable back angle that has a 10° tilt range from an upright position.

Arm choices include no arms, fixed arms, or adjustable arms that adjust 4" vertically with armpads that adjust 3/4" horizontally and pivot outward and inward over a 25° range.

Fire-retardant chair meets CAL 133 requirements; this chair is manufactured with cushions covered with a fire-barrier material and is upholstered in approved fire-retardant fabrics.

Notes

To help determine chair size, see Ergon 3® Chair Size/Fit Reference in Appendices. A-, B-, and C-size chairs are tested and warranted for use by persons 300 pounds and under.

Knee tilt option (2) is not available on C-size chairs.

For information on casters and glides, see Casters and Glides in Appendices.

Customer's Own Material (COM) requires 1½ yards for sizes A, B, and B mid-back and 1⅔ yards for size C; add ¾ yard to chair with fabric-back outer shells. Customer's Own Leather (COL) requires 24 square feet for all sizes; add 8 square feet to chair with leather-back outer shells (FB option) and an additional 8 square feet when specifying upholstered armpads. See Order Information in Appendices.

Dimensions

Knee Tilt With Forward Angle

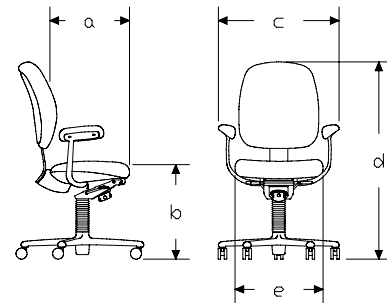

	Size A	Size B Mid-Back	Size B	Size C
a	15 3/4	16 3/4	16 3/4	18 1/2
b	15 1/2 - 20 1/2	16 - 20 3/4	16 - 20 3/4	16 - 21
c	25 1/2	26 1/2	26 1/2	27 3/4
d	41 max	40 max	44 3/4 max	45 1/4 max
e	19	20 1/4	20 1/4	21 1/2

All dimensions are in inches.

Swivel

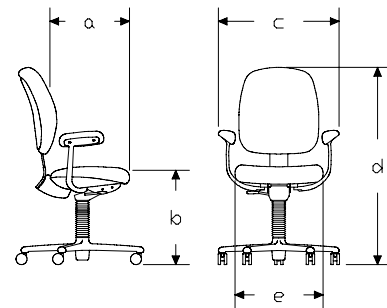

	Size A	Size B Mid-Back	Size B	Size C
a	15 3/4	16 3/4	16 3/4	18 1/2
b	15 1/2 - 20 1/2	16 - 21	16 - 21	16 1/2 - 21 1/2
c	25 1/2	26 1/2	26 1/2	27 3/4
d	41 max	41 1/4 max	45 max	45 3/4 max
e	19	20 1/4	20 1/4	21 1/2

All dimensions are in inches.

Specification Information

Step 1.

EE12

Step 2. Tilt

- 2** knee tilt
- 3** knee tilt with forward angle

Step 3. Arms

- N** no arms
- P** fixed arms, vinyl
- L** fixed arms, leather
- A** adjustable arms, vinyl
- R** adjustable arms, leather

Step 4. Size/Back Height

For knee tilt (2)

- A** a size and high back
- K** b size and mid-back
- B** b size and high back

For knee tilt with forward angle (3)

- A** a size and high back
- K** b size and mid-back
- B** b size and high back
- C** c size and high back

Step 5. Fire Retardancy

For not fire retardant (), skip this step.*

For no arms (N), fixed arms, vinyl (P), or adjustable arms, vinyl (A)

FR fire retardant

For fixed arms, leather (L) or adjustable arms, leather (R), skip this step.

Prices for Steps 1-5.

			*	FR
EE122	N	A	\$835	899
		K	\$835	899
		B	\$835	899
P	A	\$963	1029	
	K	\$963	1029	
	B	\$963	1029	
L	A	\$963	—	
	K	\$963	—	
	B	\$963	—	

A	A	\$1064	1130	
	K	\$1064	1130	
	B	\$1064	1130	
R	A	\$1064	—	
	K	\$1064	—	
	B	\$1064	—	
EE123	N	A	\$894	958
		K	\$894	958
		B	\$894	958
	C	\$894	958	
P	A	\$1023	1088	
	K	\$1023	1088	
	B	\$1023	1088	
	C	\$1023	1088	
L	A	\$1023	—	
	K	\$1023	—	
	B	\$1023	—	
	C	\$1023	—	
A	A	\$1123	1211	
	K	\$1123	1211	
	B	\$1123	1211	
	C	\$1123	1211	
R	A	\$1123	—	
	K	\$1123	—	
	B	\$1123	—	
	C	\$1123	—	

Step 6. Back Angle

- N4** not adjustable +\$0
- AJ** adjustable +\$115

Step 7. Base Finish/Frame and Outer Shell Finish

- BU** black umber +\$0
- MT** medium tone +\$0

Step 8. Casters/Glides

- BB** 2½" hard caster, black yoke, carpet +\$0
- GE** 2" glide, hard floors or carpet +\$0
- C7** 2½" caster, black yoke, hard floors or carpet +\$40
- C9** 2½" braking caster, black yoke, hard floors or carpet +\$40

Step 9. Outer Shell Finish

- U6** nonupholstered +\$0
- FB** fabric back +\$160

Step 10. Armpad Finish

For fixed arms, vinyl (P) or adjustable arms, vinyl (A)

BK black +\$0

MT medium tone +\$0

For fixed arms, leather (L) or adjustable arms, leather (R)

AT upholstered armpad, leather +\$40

Step 11. Fabric

See application chart and textiles list for fabric usage and numbers. First 2 digits of number indicate fabric line; remaining digit(s) indicate fabric color.

ColorGuard vinyl and continuum fabrics not available on FB outer shell.

For fixed arms, leather (L) or adjustable arms, leather (R)

Price Category 7 +\$180

For no arms (N), fixed arms, vinyl (P), or adjustable arms, vinyl (A) with not fire retardant

Price Category 1 +\$0

Price Category 2 +\$25

Price Category 3 +\$50

Price Category 4 +\$80

Price Category 7 +\$180

Price Category B +\$56

Price Category E +\$140

Price Category F +\$194

Price Category G +\$250

Price Category H +\$335

For no arms (N), fixed arms, vinyl (P), or adjustable arms, vinyl (A) with fire retardant (FR)

Price Category 1 +\$0

Price Category 2 +\$25

Price Category 3 +\$50

Adjustable Arm Kit

EE900

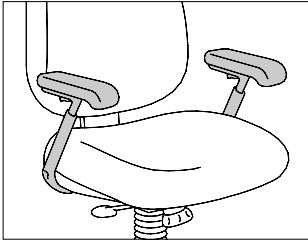

Ergon 3® Accessories

Product Information

Description
 These arms retrofit to an Ergon 3® chair. They adjust 4" vertically with armpads that adjust 3/4" horizontally and pivot outward and inward over a 25° range. Attachment hardware is included.
 Fire-retardant arms meet CAL 133 requirements.

Notes
 Customer's Own Leather (COL) requires 8 square feet. See Order Information in Appendices.

Dimensions

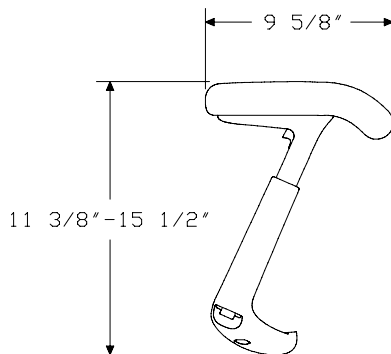

Specification Information

Step 1.

EE900A

Step 2. Armpad Upholstery

N nonupholstered armpads
F upholstered armpads, leather

Step 3. Fire Retardancy

For not fire retardant (), skip this step.*

For nonupholstered armpads (N)

FR fire retardant

For upholstered armpads, leather (F), skip this step.

Prices for Steps 1-3.

	*	FR
EE900A N	\$241	254
F	\$290	—

Step 4. Frame Finish

BU black umber +\$0
MT medium tone +\$0

Step 5. Armpad Finish

For nonupholstered armpads (N)

BK black +\$0
MT medium tone +\$0

Step 6. Armpad Leather

For upholstered armpads, leather (F) with not fire retardant
See application chart and textiles list for fabric usage and numbers. First 2 digits of number indicate leather line; remaining digit(s) indicate leather color.

Price Category 7 +\$0

Foot Pillow

EE900



Product Information

Description

This pillow elevates and supports feet. It can be used with any work chair.

Notes

Customer's Own Material (COM) requires 1 yard. Customer's Own Leather (COL) requires 7 square feet. See Order Information in Appendices.

Dimensions

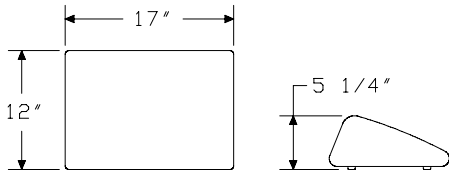

Specification Information

Step 1.

EE9003 \$223

Step 2. Fabric

See application chart and textiles list for fabric usage and numbers. First 2 digits of number indicate fabric line; remaining digit(s) indicate fabric color.

Price Category 1	+\$0
Price Category 4	+\$12
Price Category 7	+\$20
Price Category 9	+\$98

Ergon 3® Accessories

For more information about our products and services or to see a list of dealers, please visit us at www.HermanMiller.com or call (800) 851 1196.

This book is recyclable. Printed in U.S.A. on recycled paper.

© 2009 Herman Miller, Inc., Zeeland, Michigan

© HermanMiller, , Abak, Action Office, Aeron, Ambi, Ardea, Aside, Avive, Babble, C2, Caper, Celle, Co/Struc, DOT, Eames, Embody, Equa 2, Ergon 3, Ethospace, Fine-Tune, FlexFront, Formcoat, Ground Cloth, Herman Miller for Healthcare, Herman Miller Options, Intersect, Kinemat, Leaf, Lifework, Limerick, Meridian, Mirra, Passage, Pedastool, Pellicle, Perspectives, PostureFit, Prospects, Quadrant, Reaction, Resolve, RoomTune, Scooter, Stoa, Teneo, V-Wall, Vary Easy, Vivo, and Z-Axis are among the registered trademarks of Herman Miller, Inc., and its owned subsidiaries.

™ About Face, AireWeave, Airia, Arrio, Backfit, Boomerang, Bubbletack, Burdick Group, Celeste, Cellular Suspension, CLT, CoActive, Cognita, Compass, Cygnus, Enchord, EnhancedAccess, E-Wall, Flex-Edge, Flute, Harmonic, Herman Miller for the Home, Herman Miller International Collection, Herman Miller Select, Hopsak 2, Intent, Iota, Keyless Entry, Latitude, Lyris, Multiscrim, My Studio Environments, Nelson, Pixelated Support, Programmable Environments, Q, Rapunzel, Recline Selector, Sense, Setu, Stackable, Stackable Storage, The Be Collection, Thinking is good for you, TriFlex, Tu, and Twist are among the trademarks of Herman Miller, Inc., and its owned subsidiaries.

SM TAP, Textile Alliance Program and Thoughtpile are among the service marks of Herman Miller, Inc.

Chemsurf is a registered trademark of Wilsonart International.

Corian is a registered trademark of DuPont.

FLEXNET is a trademark of Milliken & Co.

Floor Saver Glide™ is a trademark of Carpin Manufacturing Inc.

Geiger is a registered trademark of Geiger International.

Goetz is a trademark of Mark W. Goetz.

Hang-It-All is a registered trademark of Lucia Eames Demetrios, d.b.a. Eames Office.

Holophane is a registered trademark of Holophane.

Ingeo is a trademark of Cargill Dow LLC.

Microsoft and Natural Keyboard are registered trademarks of Microsoft Corporation.

Noguchi® is a registered trademark of The Isamu Noguchi Foundation and Garden Museum.

Qt Quiet technology and Qt are trademarks of Cambridge Sound Management, Inc.