

# My Studio Environments™

Prices effective December 7, 2009

<b>Introduction</b>	<b>page 2</b>
<b>My Studio Environments™</b>	<b>3</b>
Infrastructure	5
Walls	5
Energy Distribution	20
Cladding	31
Work Surfaces	48
Display Components	63
Storage	66
<b>Indices</b>	<b>99</b>
By Name	99
By Number	101
<b>Appendices</b>	
To view and/or print price book appendices, select the appropriate price book from <a href="http://www.HermanMiller.com">www.HermanMiller.com</a> .	



# Introduction

## A Note on the Organization of This Book

There are a few signals that will help you understand the organization of this book. Once you know them, you should be able to find your way around easily.

### Like a newspaper, this book is formatted with columns of text and illustrations that run vertically.

Information wraps from one column to the next and continues for as many pages as it needs to.

### Black bars are clues.

A black bar at the top of a page signals the start of information about a product.

This information is divided into two sections, each signaled by a black bar. Product Information includes a description, additional notes, and dimensional drawings. Specification Information, which always begins at the top of a column, includes a series of steps. Each step represents a decision you need to make in order to complete your product number. Steps must be followed sequentially. The number of pages needed to complete information on a product varies; some will be complete in one page; others may fill three or four pages. Just continue going through the steps until you run into the next product, signaled by the black bar at the top of the page.

Black tabs running along the outside edge of the page help you locate what section you are in or what section you want to go to. You can thumb forwards or backwards to find a section; tabs and text appear on both sides of the page.

The additional pages in the back of the book include the appendices and indices. They are signaled by a long black bar running along the outside edge of the page.

### The index is presented two ways.

The first index is in alphabetical order by product name. It can be helpful if you are new to the products and numbering scheme or if you are looking for a type of product, such as work chair or round table.

The second index is by product number. It lists, in alphanumeric order, the base product number, typically a five-digit number.

## General Information

This book is effective December 7, 2009, subject to change without notice. Products may be purchased from authorized Herman Miller dealers who will quote prices upon request. For more information about our products and services or to see a list of dealers, visit [www.HermanMiller.com](http://www.HermanMiller.com).

All prices are list prices. Additional services, such as planning services, design, storage, and installation, are not included and must be added to these prices when the additional services are requested.

Illustrations, specifications, and prices are based on the latest information at the time of publication. The right is reserved to make changes at any time without notice in prices, fabrics, finishes, materials, specifications, and models, and also to discontinue models and finishes.

Dimensions shown in the drawings are engineering drawing dimensions rounded up to the nearest  $\frac{1}{8}$ ". Product is shipped set up or knocked down. Products that include "Shipped knocked down" in the description require some assembly. If this statement does not appear in the description, the product is shipped assembled.

Service problems are normally handled by a Herman Miller authorized dealer. Where this cannot be accomplished on a local level, service problems should be referred to the Customer Care Representative for your region, Herman Miller, Inc., Zeeland, Michigan 49464.

### 20-Day or Less/Assigned Lead-Time Shipments

All products and options in this price book not designated by an Assigned Program icon  will ship in **20 business days or less** after being acknowledged by Herman Miller.

Products and options designated by an  are on the assigned lead-time program and may ship in 20 days, less than 20 days, or more than 20 days from order acknowledgement.

**Infrastructure**

**Work Surfaces**

**Display Components**

**Storage**



# Center Wall Frame

NT110.

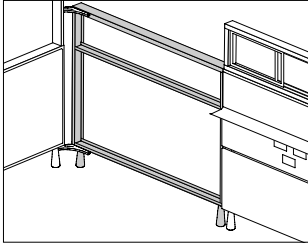

### Product Information

#### Description

This 46"-high frame holds individual cladding on both sides and creates the center wall of an office. It accepts easels, ledges, center wall cladding, and a transom. Each frame has an optional smooth top cap and two 4"-high glides with 2" of leveling adjustment; glides are fog grey (LY).

The powered frame has an electrical harness that distributes double-sided, 4-circuit power in the electrical zone. The electrical zone is 11" high and is located 22" from the floor. Electrical components are UL listed for USA and Canada.

#### Notes

Center wall frames connect in a straight line. Order center wall attachment hardware (NT111.) separately.

Side wall frames connect to a center wall frame at 12" increments. Order side wall frame (NT120.) separately.

Order ledges separately:

- Inside ledge (NT117.)
- Outside ledge (NT118.)

Order center wall cladding separately:

- Center wall aisle cladding (NT142.)
- Center wall display zone cladding (NT143.)
- Center wall lower cladding (NT140.)
- Center wall power/data cladding (NT141.)

Center wall transom can be added to the top of a center wall frame.

Specify frame with no top cap (NT110.A) and order center wall transom (NT112.) separately.

For applications without center wall transom, specify top cap (NT110.B).

To access power on center wall, order center wall power/data cladding (NT141.) separately.

For powered frame with access, order receptacles (NT176. or NT177.) separately.

For hard-wired frame, specify nonpowered center wall frame (NT110.N).

To manage and separate voice/data cables within center wall frame, order cable manager (NT178.) separately.

### Dimensions

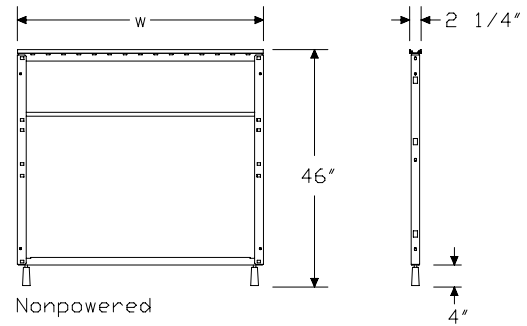

Nonpowered

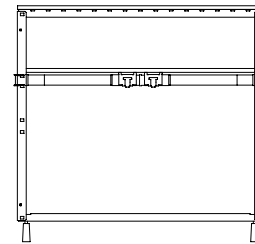

Powered



# Center Wall Attachment Hardware

NT111.

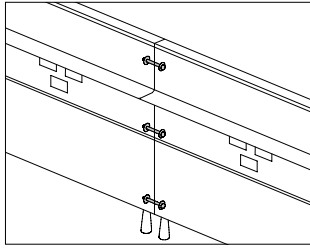

### Product Information

#### Description

These 3 bolts connect 2 center wall frames in a straight line.

#### Dimensions

### Specification Information

#### Step 1.

NT111. A

\$11

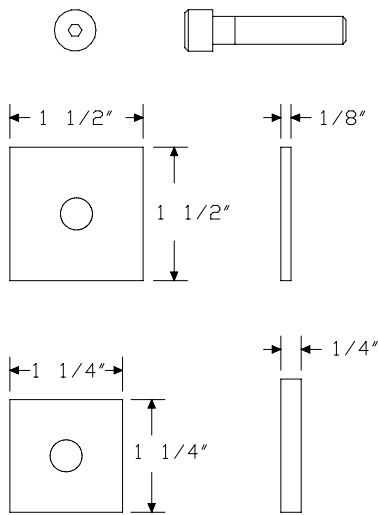

# Center Wall Transom

NT112.

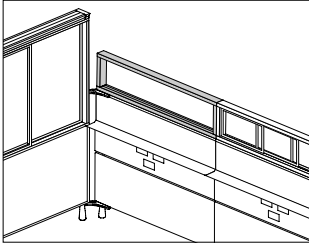

My Studio Environments™ Infrastructure

## Product Information

### Description

This 11"-high transom attaches to the top of a center wall frame. It extends the center-wall height and accepts transom shutters. The transom includes a grooved shutter track that finishes off the top of a center wall frame.

### Notes

To attach center wall transom, order center wall frame with no top cap (NT110.A).

Specify width of center wall transom to match width of center wall frame.

Order optional transom shutters (NT144.) separately.

To retrofit center wall frame to accept a center wall transom, remove center wall's smooth frame top cap and attach transom and grooved shutter track.

### Dimensions

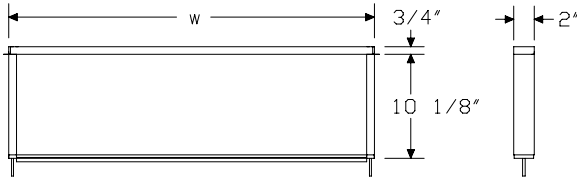

## Specification Information

### Step 1.

**NT112.11**  A

### Step 2. Width

**36** 36" wide  A

**48** 48" wide  A

### Prices for Steps 1-2.

<b>NT112.11</b>	<b>36</b>	\$130
	<b>48</b>	\$145

### Step 3. Transom Finish

**91** white  A +\$0

**CN** metallic champagne  A +\$0

**EH** metallic bronze  A +\$0

**G1** graphite  A +\$0

**MS** metallic silver  A +\$0

### Step 4. Shutter Track Finish

**CL** cool grey neutral  A +\$0

**WN** warm grey neutral  A +\$0

Center Wall Finished End

NT115.

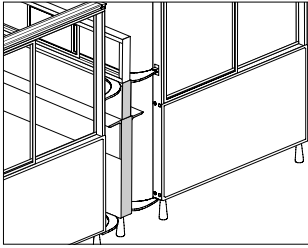

**Product Information**

**Description**

This tiered cover finishes the exposed end of a center wall frame and has a painted surface. It includes 2 plastic end caps for the inside ledge; end caps are fog grey (LY).

**Notes**

4 trim strips are optional and can be used to provide a finished look for side wall at the end of a run.

**Dimensions**

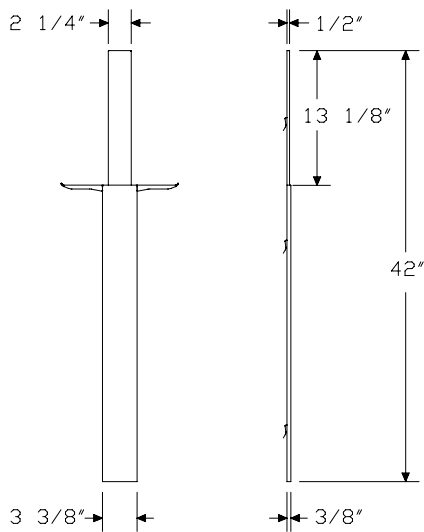

**Specification Information**

**Step 1.**

**NT115.** [A] \$79

**Step 2. Finished End Finish**

**91** white [A] +\$0  
**CN** metallic champagne [A] +\$0  
**EH** metallic bronze [A] +\$0  
**G1** graphite [A] +\$0  
**MS** metallic silver [A] +\$0

**Step 3. Side Wall Trim Finish**

**NN** no trim [A] +\$0  
**CL** cool grey neutral [A] +\$0  
**WN** warm grey neutral [A] +\$0

# Inside Ledge

NT117.

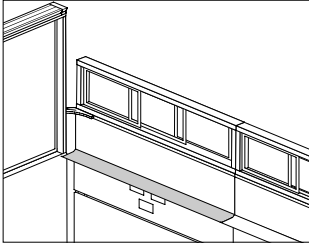

My Studio Environments™ Infrastructure

## Product Information

### Description

This 4"-deep aluminum shelf attaches to the interior side of a center wall to provide a display area or storage for small items. It sits above the center wall power/data cladding, supports the easel, and holds the center wall display zone cladding.

### Notes

Specify width of ledge to match width of center wall.

### Dimensions

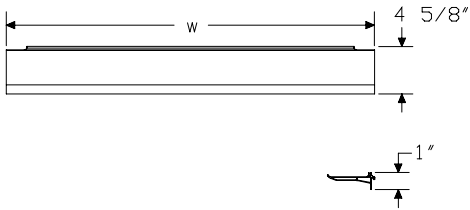

## Specification Information

### Step 1.

**NT117.** A

### Step 2. Width

**36** 36" wide A

**48** 48" wide A

### Prices for Steps 1-2.

<b>NT117. 36</b>	\$41
<b>48</b>	\$50

# Outside Ledge

NT118.

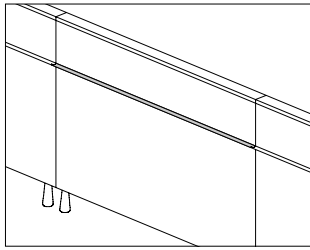

### Product Information

#### Description

This aluminum trim finishes the aisle side of a center wall.

#### Notes

Specify width of ledge to match width of center wall.

#### Dimensions

### Specification Information

#### Step 1.

**NT118.**  A

#### Step 2. Width

**36** 36" wide  A

**48** 48" wide  A

#### Prices for Steps 1-2.

<b>NT118. 36</b>	\$41
<b>48</b>	\$50

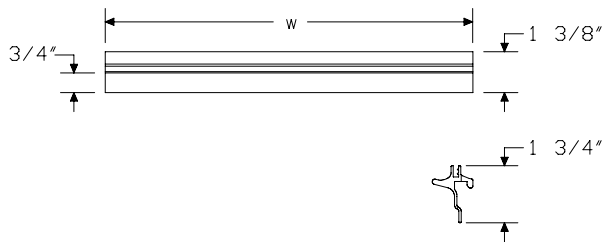

# Side Wall Frame

NT120.

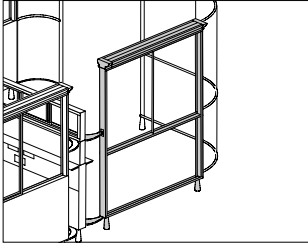

My Studio Environments™ Infrastructure

## Product Information

### Description

This frame connects to a center wall frame at a 90° angle. It holds side wall cladding and side wall shutters. The frame has 6 frame hole plugs, two 4"-high glides with 2" of leveling adjustment, and 2 offset brackets for attaching the side wall frame to the center wall frame. Glides and offset brackets are fog grey (LY). Shipped knocked down.

### Notes

For 6'-wide offices, specify 54"-wide side wall. For 8'-wide offices, specify 78"-wide side wall.

Side wall frames connect to a center wall frame at 12" increments.

Order side wall cladding (NT150.) or side wall shutter (NT152.) separately.

For 46"-high side wall, order optional tool rail (NT413.) separately. For 68"-high side wall, order optional rolling tool rail (NT412.) separately.

## Dimensions

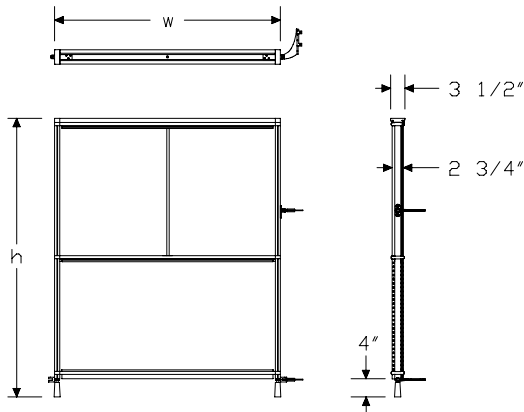

## Specification Information

### Step 1.

**NT120.**  A

### Step 2. Height

**46** 46" high  A

**68** 68" high  A

### Step 3. Width

**54** 54" wide  A

**78** 78" wide  A

### Prices for Steps 1-3.

	<b>54</b>	<b>78</b>
<b>NT120. 46</b>	\$478	555
<b>68</b>	\$575	653

### Step 4. Finish

<b>CN</b>	metallic champagne <input type="checkbox"/> A	+ \$0
<b>EH</b>	metallic bronze <input type="checkbox"/> A	+ \$0
<b>MS</b>	metallic silver <input type="checkbox"/> A	+ \$0

# Wall Start, Side Wall

NT124.

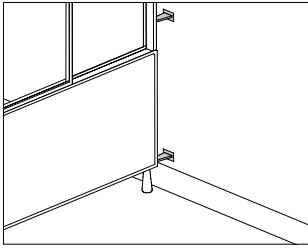

### Product Information

#### Description

This bracket attaches a side wall to an architectural wall or column at a 90° angle. It is used in place of offset brackets. Package contains 2 brackets. Attachment hardware is included for attaching the wall start bracket to a side wall.

Wall start provides a 4" gap between the architectural wall and side wall. This allows for proper attachment of a bookcase or surface support. The gap is also consistent with the gap between a side wall and center wall.

#### Notes

Specify 1 wall start per side wall.

Hardware to attach wall start to architectural wall must be field supplied.

#### Dimensions

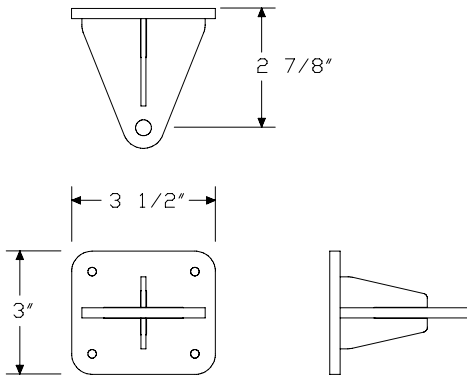

### Specification Information

#### Step 1.

**NT124.** [A] \$91

#### Step 2. Finish

<b>CN</b>	metallic champagne [A]	+\$0
<b>EH</b>	metallic bronze [A]	+\$0
<b>MS</b>	metallic silver [A]	+\$0

# Seismic Anchor Kit

NT119.

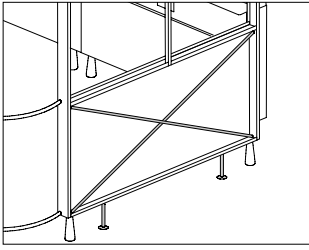

My Studio Environments™ Infrastructure

## Product Information

**Description**  
 This hardware kit secures My Studio Environments to the floor in regions where seismic bracing is required by local code. It attaches to a side wall frame (between the side wall cladding) and includes 2 cross-braces and 2 floor anchors. One kit is required for each side wall frame.

**Notes**  
 Specify width of anchor to match width of side wall frame.  
 Seismic anchor required when using 81"-high streetside frames in portions of southern California.

## Dimensions

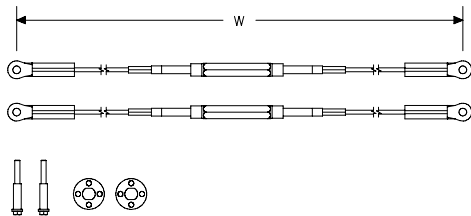

## Specification Information

**Step 1.**

**NT119.W** A

**Step 2. Application**

**54** for 54"-wide side wall A

**78** for 78"-wide side wall A

**Prices for Steps 1-2.**

<b>NT119.W 54</b>	<b>\$330</b>
<b>78</b>	<b>\$345</b>

# Streetside Curved Frame

NT130.

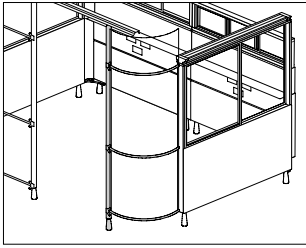

### Product Information

#### Description

This frame connects to a side wall frame and a streetside straight frame. It holds individual cladding on the outside of the frame. The frame has a 4"-high glide with 2" of leveling adjustment; the glide is fog grey (LY). Butterfly clips are included for attachment. Shipped knocked down.

#### Notes

46"-high curved frame includes a top trim piece.

81"-high curved frames must use a header (NT134.); order separately.

Connect curved frame as follows:

Side Wall—Curved Frame—Straight Frame

46" high—46" high—46" high

68" high—68" high—68" high

68" high—81" high—81" high

For 46"-high curved frame, specify position as follows:

- When inside office facing the doorway, specify left-hand position for curved frame on left side of office opening
- When inside office facing the doorway, specify right-hand position for curved frame on right side of office opening

68"- and 81"-high curved frames have a top horizontal rail with holes for attaching a coat hook.

#### Dimensions

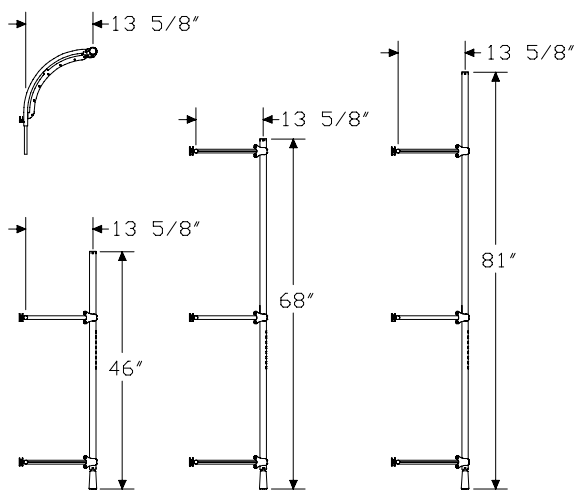

### Specification Information

#### Step 1.

**NT130.**  A

#### Step 2. Height

**46** 46" high  A

**68** 68" high  A

**81** 81" high  A

#### Step 3. Position

*For 46" high (46)*

**L** left-hand position  A

**R** right-hand position  A

*For 68" high (68) or 81" high (81)*

**N** nonhanded  A

#### Prices for Steps 1-3.

	L	N	R
<b>NT130. 46</b>	\$295	—	295
<b>68</b>	—	\$314	—
<b>81</b>	—	\$332	—

#### Step 4. Finish

**CN** metallic champagne  A +\$0

**EH** metallic bronze  A +\$0

**MS** metallic silver  A +\$0

# Streetside Straight Frame

NT131.

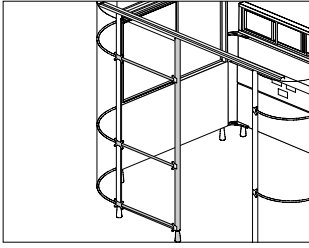

My Studio Environments™ Infrastructure

## Product Information

### Description

This frame connects to a streetside curved frame or to another streetside straight frame. It holds individual cladding on the outside of the frame. The frame has a 4"-high glide with 2" of leveling adjustment; the glide is fog grey (LY). Butterfly clips are included for attachment. Shipped knocked down.

### Notes

Specify height of straight frame to match height of connecting curved frame or straight frame.

46"-high straight frame includes a top trim piece.

81"-high straight frames must use a header (NT134.); order separately.

When door is used, header attaches to 81"-high straight frame.

### Dimensions

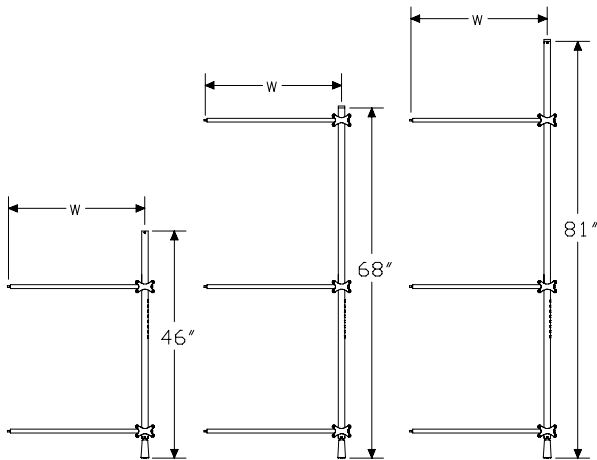

## Specification Information

### Step 1.

**NT131.**  A

### Step 2. Height

**46** 46" high  A

**68** 68" high  A

**81** 81" high  A

### Step 3. Width

**24** 24" wide  A

**28** 28" wide  A

### Prices for Steps 1-3.

	24	28
<b>NT131. 46</b>	\$358	373
<b>68</b>	\$377	398
<b>81</b>	\$377	407

### Step 4. Finish

<b>CN</b>	metallic champagne <input type="checkbox"/> A	+\$0
<b>EH</b>	metallic bronze <input type="checkbox"/> A	+\$0
<b>MS</b>	metallic silver <input type="checkbox"/> A	+\$0

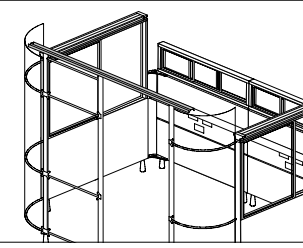

**Product Information**

**Description**  
 This painted-steel header attaches to the streetside of an office. It provides stability for an 81"-high streetside frame run and supports and guides a door. The header includes predrilled holes for attachment to streetside frames in 8', 10', 12', and 16'-wide offices. Attachment hardware is included.

**Notes**

Actual header widths are as follows:  
 Office Size—Header Size  
 8'-wide office—83"-wide header  
 10'-wide office—107"-wide header  
 12'-wide office—131"-wide header  
 16'-wide office—179"-wide header

For planning information, see Header Planning section in My Studio Environments™ Planning Guide.

**Dimensions**

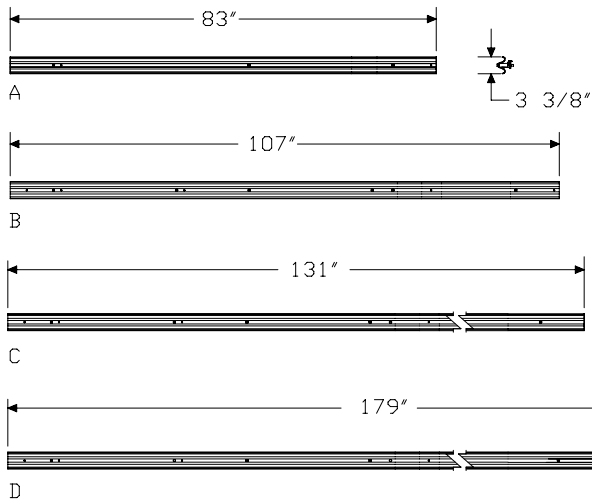

**Specification Information**

**Step 1.**

**NT134.**  A

**Step 2. Application**

- A** for 8'-wide office  A
- B** for 10'-wide office  A
- C** for 12'-wide office  A
- D** for 16'-wide office  A

**Prices for Steps 1-2.**

<b>NT134. A</b>	\$82
<b>B</b>	\$99
<b>C</b>	\$157
<b>D</b>	\$175

**Step 3. Finish**

<b>CN</b> metallic champagne <input type="checkbox"/> A	+\$0
<b>EH</b> metallic bronze <input type="checkbox"/> A	+\$0
<b>MS</b> metallic silver <input type="checkbox"/> A	+\$0

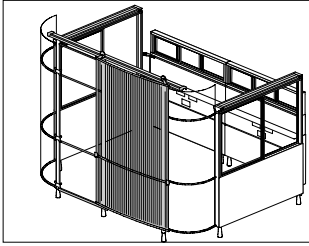

**Product Information**

**Description**

This plastic door provides enclosure and added privacy. It has a steel frame, door guide, rubber stoppers, and wheels. The door is nonhanded and opens to the left or right. The handle is approximately 29½" above the bottom of the door.

Door handle color is predetermined:

Frame Finish—Handle Finish

Metallic bronze (EH)—Warm grey neutral (WN)

Metallic champagne (CN)—Warm grey neutral (WN)

Metallic silver (MS)—Cool grey neutral (CL)

**Notes**

Specify door application to match width of adjacent straight frame (door will open past the straight frame).

68"-high door can only be used with 68"-high streetside frame; 81"-high door can only be used with 81"-high streetside frame.

For 81"-high door, order header (NT134.) separately. Header and lower guide assembly attach to adjacent streetside straight frame.

Message board (NT431.) cannot be used in 68"-high door application.

**Dimensions**

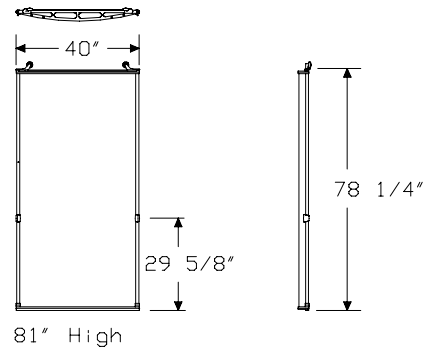
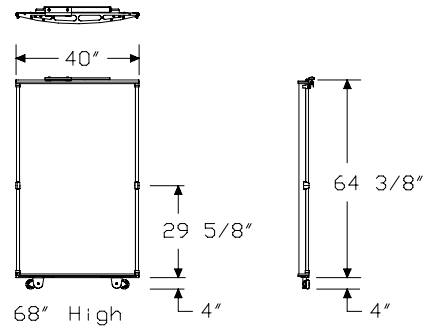

**Specification Information**

Step 1.

**NT133.**  A

Step 2. Application

**24** for 24"-wide streetside straight frame  A

**28** for 28"-wide streetside straight frame  A

Step 3. Door Height

**S** 68"-high door  A

**T** 81"-high door  A

Prices for Steps 1-3.

	<b>S</b>	<b>T</b>
<b>NT133. 24</b>	\$816	707
<b>28</b>	\$816	707

Step 4. Frame Finish

**CN** metallic champagne  A + \$0

**EH** metallic bronze  A + \$0

**MS** metallic silver  A + \$0

Step 5. Door Finish

**ZW** clear  A + \$0

# Power Harness

NT170.

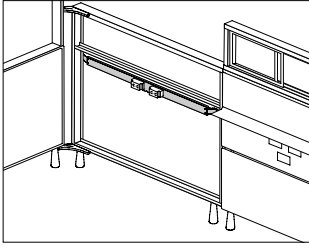

My Studio Environments™ Infrastructure

## Product Information

### Description

This harness converts a nonpowered center wall frame to a powered center wall frame. It attaches to the center rail and distributes up to 4 20-amp circuits and provides 2 receptacle locations on each side of the center wall. The harness is UL listed and CSA certified.

### Notes

Specify width of harness to match width of center wall frame.

Order 4-circuit receptacles (NT176. or NT177.) separately.

Harness must be field installed.

### Dimensions

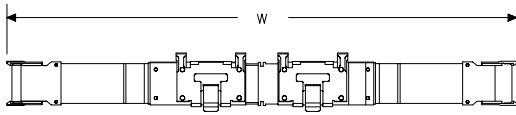

## Specification Information

### Step 1.

**NT170.** A

### Step 2. Width

**36** 36" wide A

**48** 48" wide A

### Prices for Steps 1-2.

<b>NT170. 36</b>	\$86
<b>48</b>	\$95

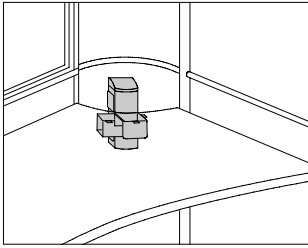

**Product Information**

**Description**

This distributor attaches to the underside of a primary surface and provides electrical and data access at surface height. It distributes up to 4 20-amp circuits and provides 2 receptacle and 2 data port locations. The distributor includes a harness that enters the center wall between the center wall lower cladding and the center wall power/data cladding. The distributor's harness plugs into the left-hand receptacle outlet of the power harness. Conduit and data cables are routed on the underside of the primary surface within a surface trough; cables are routed to the streetside corner of the primary surface. The distributor is UL listed and CSA certified.

The Chicago distributor (NNR) distributes 1 or 2 20-amp circuits. It includes a power/data distributor post enclosure, covers, and mounting hardware. J-box, receptacles, conduit, and wiring must be provided by an electrical contractor. The J-box must be ETL listed and meet standards for use in the city of Chicago.

**Notes**

- Order surface trough (NT172.) separately.
- Order 4-circuit receptacles (NT176. or NT177.) separately.

**Dimensions**

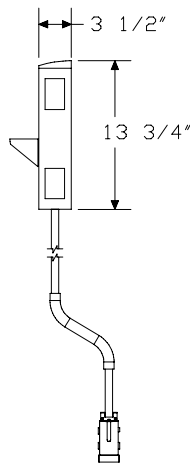

**Specification Information**

**Step 1.**

**NT171.** [A]

**Step 2. Usage**

- 54N** for 54"-wide side wall frame [A]
- 78N** for 78"-wide side wall frame [A]
- NNR** meets Chicago electrical code requirements [A]

**Prices for Steps 1-2.**

<b>NT171. 54N</b>	\$208
<b>78N</b>	\$259
<b>NNR</b>	\$194

**Step 3. Finish**

- CL** cool grey neutral [A] +\$0
- WN** warm grey neutral [A] +\$0

# Surface Trough

NT172.

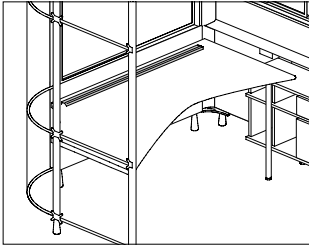

My Studio Environments™ Infrastructure

## Product Information

### Description

This plastic trough attaches to the underside of a primary surface. It is used with a power/data distributor to hold and separate conduit and voice/data cables. The trough also routes cables and extension cords along the back edge of the surface. Finish is black.

### Notes

Specify width of trough to match width of side wall frame.  
Order optional power/data distributor (NT171.) separately.

### Dimensions

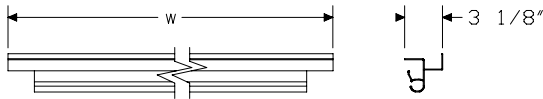

## Specification Information

### Step 1.

**NT172.** A

### Step 2. Width

**54** 54" wide A

**78** 78" wide A

### Prices for Steps 1-2.

<b>NT172. 54</b>	\$55
<b>78</b>	\$76

# Power Entry, Internal Direct Connect

NT173.

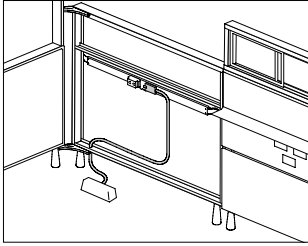

### Product Information

#### Description

This power entry connects a building's electrical supply from a wall, floor, or column to a powered center wall. It enters the center wall through cutouts in the center wall frame's bottom rail and plugs into the right-hand receptacle outlet on the power harness. The power entry includes a cable that can be field cut to the appropriate length. Due to the location of the power entry connection, only 3 receptacle locations remain available in the power harness. The power entry is UL listed and CSA certified.

#### Notes

Licensed electrician must wire power entry.

#### Dimensions

### Specification Information

#### Step 1.

**NT173.**  A

#### Step 2. Length

- 06** 6' long  A
- 12** 12' long  A
- 18** 18' long  A
- 24** 24' long  A

#### Prices for Steps 1-2.

<b>NT173. 06</b>	\$121
<b>12</b>	\$169
<b>18</b>	\$206
<b>24</b>	\$243

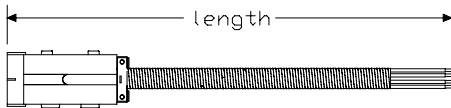

Floor Power Entry, New York City NT174.

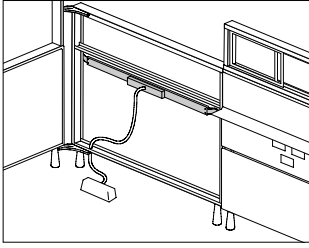

**Product Information**

**Description**  
 This power entry connects a building’s electrical supply from a wall, floor, or column into a nonpowered center wall frame. It distributes up to 4 20-amp circuits to a power harness in the adjacent center wall frame. The power entry has a 60-cubic-inch capacity and distributes power in both directions. It includes a junction box and 2 wire harnesses. The power entry does not provide receptacle access. It is UL listed for USA and Canada.

**Notes**

- Specify width of power entry to match width of center wall frame.
- Exterior wires connecting center wall frame’s junction box to building’s electrical supply must be covered.
- Licensed electrician must supply and wire conduit and conduit connector.
- Licensed electrician must wire connection to center wall frame’s electrical harness when local electrical codes require wiring connections inside junction box.
- Power entry must be field installed.

**Dimensions**

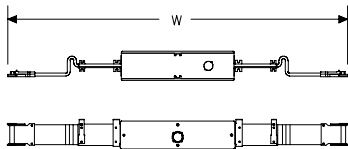

**Specification Information**

Step 1.

**NT174.** A

Step 2. Width

**36** 36" wide A

**48** 48" wide A

Prices for Steps 1-2.

<b>NT174. 36</b>	\$224
<b>48</b>	\$244

# Ceiling Power Entry

NT175.

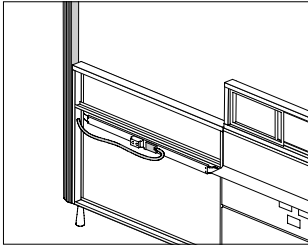

### Product Information

#### Description

This power entry connects a ceiling's electrical supply to the power harness in a center wall. It distributes up to 4 20-amp circuits. The power entry has a 10'-high pole that can be field cut to the appropriate length, ceiling trim, connecting hardware, conduit, and a factory-installed electrical harness that plugs into the right-hand receptacle outlet on the power harness. Due to the location of the power entry connection, only 3 receptacle locations remain available in the power harness. The power entry includes 2 inside ledge end caps. It is UL listed for USA and Canada.

#### Notes

When using ceiling power entry, center wall finished end is not required. 4 trim strips are optional and can be used to provide a finished look for side wall at the end of a run.

Internal electrical wires must be covered with conduit to separate electrical and data cables.

Licensed electrician must wire power entry.

For cable capacity information, see Cable Capacity Charts in Kiosk.

### Dimensions

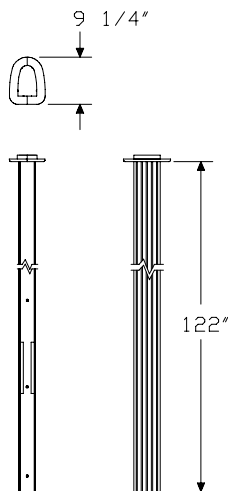

### Specification Information

#### Step 1.

**NT175.**  A

#### Step 2. Power

**N** nonpowered  A

**P** powered  A

#### Prices for Steps 1-2.

<b>NT175. N</b>	\$359
<b>P</b>	\$606

#### Step 3. Power Entry Finish

**CL** cool grey neutral  A +\$0

**WN** warm grey neutral  A +\$0

#### Step 4. Side Wall Trim Finish

**NN** no trim  A +\$0

**CL** cool grey neutral  A +\$0

**WN** warm grey neutral  A +\$0

# Receptacle, 15 Amp

NT176.

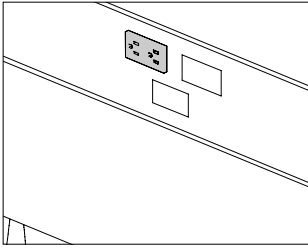

My Studio Environments™ Infrastructure

## Product Information

### Description

This duplex receptacle locks into the power harness of a center wall. It is UL listed and CSA certified. Package contains 6.

### Notes

When receptacle locks into power harness of center wall, receptacle extends approximately 1/4" from face of center wall power/data cladding.

### Dimensions

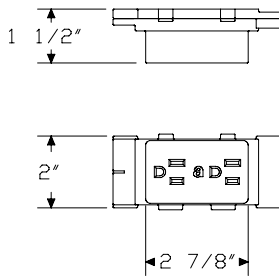

## Specification Information

### Step 1.

**NT176.**  A

### Step 2. Type

- A** duplex, circuit a  A
- B** duplex, circuit b  A
- C** duplex, circuit c  A
- BI** duplex, circuit b, isolated ground  A
- CI** duplex, circuit c, isolated ground  A
- D** duplex, circuit d, isolated ground  A
- CS** duplex, 3 circuit, circuit c, isolated ground  A

### Prices for Steps 1-2.

<b>NT176. A</b>	\$118
<b>B</b>	\$118
<b>C</b>	\$118
<b>BI</b>	\$118
<b>CI</b>	\$118
<b>D</b>	\$118
<b>CS</b>	\$118

### Step 3. Finish

<b>91</b> white <input type="checkbox"/> A	+\$0
<b>CL</b> cool grey neutral <input type="checkbox"/> A	+\$0
<b>G1</b> graphite <input type="checkbox"/> A	+\$0
<b>WN</b> warm grey neutral <input type="checkbox"/> A	+\$0

# Receptacle, 20 Amp

NT177.

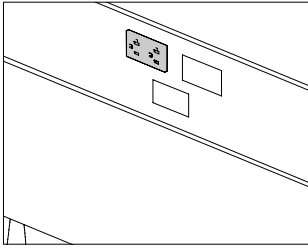

### Product Information

#### Description

This receptacle locks into a 4-circuit electrical harness to provide power to equipment with a 20-amp standard plug head or cap. It also accepts 15-amp standard plug heads or caps. The receptacle is UL listed and CSA certified; includes 1 receptacle.

#### Notes

Receptacle cannot be used with hard-wired center wall frame.  
When receptacle locks into power harness of center wall, receptacle extends approximately 1/4" from face of center wall power/data cladding.

#### Dimensions

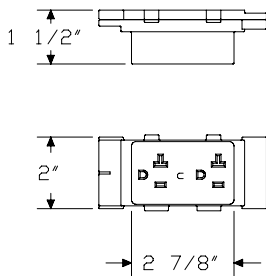

### Specification Information

#### Step 1.

**NT177.**  A

#### Step 2. Type

- AT** circuit a  A
- BT** circuit b  A
- CT** circuit c  A
- BIT** circuit b, isolated ground  A
- CIT** circuit c, isolated ground  A
- DT** circuit d, isolated ground  A

#### Prices for Steps 1-2.

<b>NT177. AT</b>	\$28
<b>BT</b>	\$28
<b>CT</b>	\$28
<b>BIT</b>	\$28
<b>CIT</b>	\$28
<b>DT</b>	\$28

#### Step 3. Finish

<b>91</b> white <input type="checkbox"/> A	+\$0
<b>CL</b> cool grey neutral <input type="checkbox"/> A	+\$0
<b>G1</b> graphite <input type="checkbox"/> A	+\$0
<b>WN</b> warm grey neutral <input type="checkbox"/> A	+\$0

# Center Wall Cable Manager

NT178.

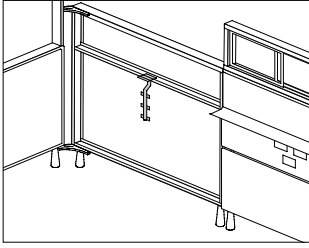

My Studio Environments™ Infrastructure

## Product Information

### Description

This plastic cable manager attaches to the center rail inside a center wall frame to manage and separate power/data cables. It has 2 holes at 3 locations to accept standard cable ties. Finish is black. Package contains 12.

### Notes

For cable capacity, see My Studio Environments™ Planning Guide.  
Cable ties must be supplied by installers.

### Dimensions

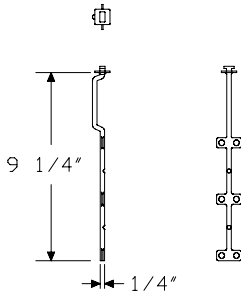

## Specification Information

### Step 1.

NT178. A

\$39

# Surface Cable Management Kit

NT179.

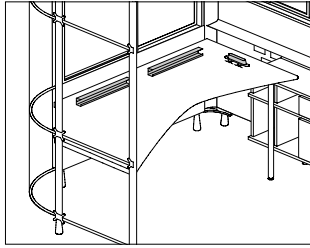

### Product Information

#### Description

This cable management kit attaches to the underside of a primary surface to hold and manage power/data cables. It includes 2 14"-wide troughs and 1 cord cleat. Finish is black.

#### Notes

To accept cables routed directly from receptacles, attach cord cleat to primary surface end that is closest to the center wall.

For additional cable management, order surface trough (NT172.) separately.

#### Dimensions

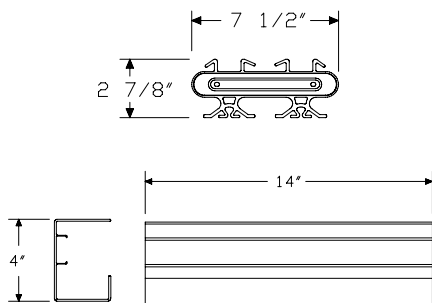

### Specification Information

#### Step 1.

NT179. A

\$45

Surface-Attached Receptacle

NT180.

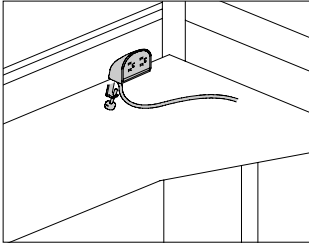

My Studio Environments™ Infrastructure

**Product Information**

**Description**

This 2-outlet receptacle attaches to the back edge of a secondary surface or primary surface without a surface trough. It provides electrical access at surface height. Cord length is 9'. Attachment hardware is included.

**Dimensions**

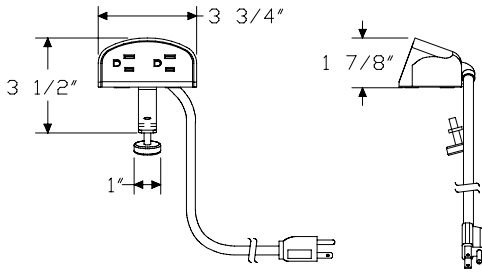

**Specification Information**

**Step 1.**

**NT180.** [A] \$105

**Step 2. Finish**

**CL** cool grey neutral [A] +\$0  
**WN** warm grey neutral [A] +\$0

# Center Wall Lower Cladding

NT140.

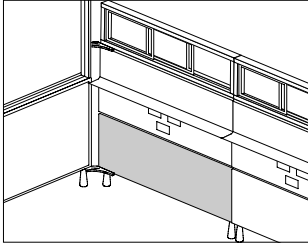

## Product Information

### Description

This 18"-high painted cladding attaches to 1 side of a center wall frame's lower zone. It includes a 1/2"-wide rubber trim along the top edge; this trim conceals the opening where a power/data distributor's conduit exits. Trim color is fog grey (LY). Attachment clips are included.

### Notes

Specify width of cladding to match width of center wall frame.

### Dimensions

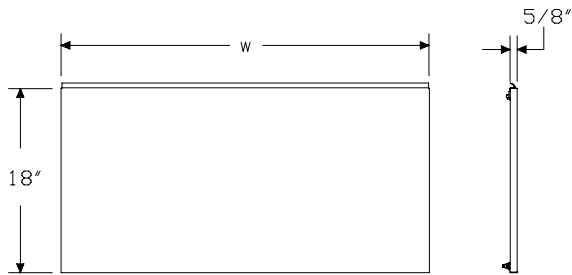

## Specification Information

### Step 1.

**NT140.**  A

### Step 2. Width

**36P** 36" wide  A

**48P** 48" wide  A

### Prices for Steps 1-2.

<b>NT140. 36P</b>	\$94
<b>48P</b>	\$104

### Step 3. Surface Finish

#### Sand Texture Paint

<b>7L</b>	dune <input type="checkbox"/> A	+\$0
<b>7M</b>	chai <input type="checkbox"/> A	+\$0
<b>7N</b>	grass <input type="checkbox"/> A	+\$0
<b>7U</b>	blue ridge <input type="checkbox"/> A	+\$0
<b>7V</b>	loden <input type="checkbox"/> A	+\$0
<b>7W</b>	napa <input type="checkbox"/> A	+\$0
<b>7Y</b>	sedona <input type="checkbox"/> A	+\$0
<b>7Z</b>	mink <input type="checkbox"/> A	+\$0
<b>8T</b>	gull <input type="checkbox"/> A	+\$0
<b>8Y</b>	moonbeam <input type="checkbox"/> A	+\$0
<b>B4</b>	blue medium <input type="checkbox"/> A	+\$0
<b>ZK</b>	cappuccino <input type="checkbox"/> A	+\$0

#### Bright Sand Texture Paint

<b>91</b>	white <input type="checkbox"/> A	+\$0
<b>CL</b>	cool grey neutral <input type="checkbox"/> A	+\$0
<b>G1</b>	graphite <input type="checkbox"/> A	+\$0
<b>WN</b>	warm grey neutral <input type="checkbox"/> A	+\$0

# Center Wall Power/Data Cladding NT141.

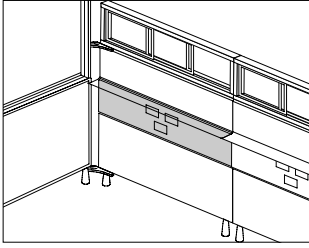

My Studio Environments™ Infrastructure

## Product Information

### Description

This 11"-high painted cladding attaches to 1 side of a center wall frame above the center wall lower cladding. It can be specified with 2 receptacle locations and 1 communication port location, which are centered on the cladding. Communication port locations are sized to hold NEMA single-gang faceplates; clips are included for the mounting hardware. The cladding includes a 1/2"-wide rubber trim along the bottom edge; this trim conceals the opening where a power/data distributor's conduit exits. Trim color is fog grey (LY). Attachment clips are included.

### Notes

Specify width of cladding to match width of center wall frame.

Order receptacles (NT176. or NT177.) separately.

To access power through power/data cladding, center wall must be powered. For nonpowered center wall frame, order power harness (NT170.) separately.

Cladding with power/data cutouts (CP) includes port covers; Chicago electrical code cladding (RP) includes a bezel.

Chicago electrical code cladding (RP) has reduced receptacle ports to accept hardwired receptacles.

## Dimensions

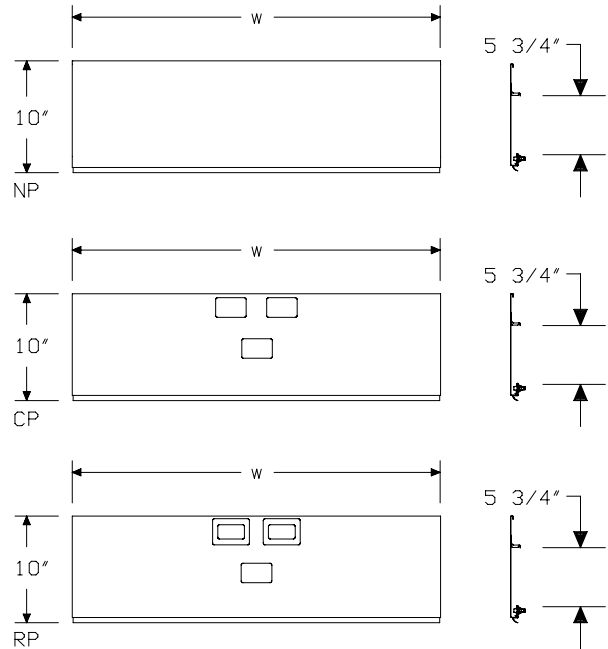

# Center Wall Power/Data Cladding

continued

## Specification Information

### Step 1.

**NT141.**  A

### Step 2. Width

**36** 36" wide  A

**48** 48" wide  A

### Step 3. Cutouts

**NP** no cutouts  A

**CP** power/data cutouts  A

**RP** power/data cutouts (meets Chicago electrical code requirements)  A

### Prices for Steps 1-3.

	NP	CP	RP
<b>NT141. 36</b>	\$87	91	97
<b>48</b>	\$95	98	105

### Step 4. Surface Finish

#### Sand Texture Paint

<b>7L</b>	dune <input type="checkbox"/> A	+\$0
<b>7M</b>	chai <input type="checkbox"/> A	+\$0
<b>7N</b>	grass <input type="checkbox"/> A	+\$0
<b>7U</b>	blue ridge <input type="checkbox"/> A	+\$0
<b>7V</b>	loden <input type="checkbox"/> A	+\$0
<b>7W</b>	napa <input type="checkbox"/> A	+\$0
<b>7Y</b>	sedona <input type="checkbox"/> A	+\$0
<b>7Z</b>	mink <input type="checkbox"/> A	+\$0
<b>8T</b>	gull <input type="checkbox"/> A	+\$0
<b>8Y</b>	moonbeam <input type="checkbox"/> A	+\$0
<b>B4</b>	blue medium <input type="checkbox"/> A	+\$0
<b>ZK</b>	cappuccino <input type="checkbox"/> A	+\$0

#### Bright Sand Texture Paint

<b>91</b>	white <input type="checkbox"/> A	+\$0
<b>CL</b>	cool grey neutral <input type="checkbox"/> A	+\$0
<b>G1</b>	graphite <input type="checkbox"/> A	+\$0
<b>WN</b>	warm grey neutral <input type="checkbox"/> A	+\$0

### Step 5.

#### Port Cover Finish

##### For power/data cutouts (CP)

<b>91</b>	white <input type="checkbox"/> A	+\$0
<b>CL</b>	cool grey neutral <input type="checkbox"/> A	+\$0
<b>G1</b>	graphite <input type="checkbox"/> A	+\$0
<b>WN</b>	warm grey neutral <input type="checkbox"/> A	+\$0

#### Bezel Finish

##### For power/data cutouts (meets Chicago electrical code requirements) (RP)

<b>91</b>	white <input type="checkbox"/> A	+\$0
<b>CL</b>	cool grey neutral <input type="checkbox"/> A	+\$0
<b>G1</b>	graphite <input type="checkbox"/> A	+\$0
<b>WN</b>	warm grey neutral <input type="checkbox"/> A	+\$0

# Center Wall Aisle Cladding

NT142.

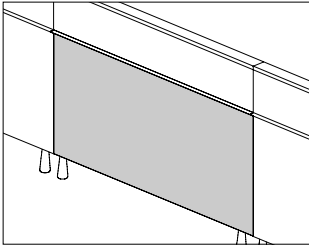

My Studio Environments™ Infrastructure

## Product Information

### Description

This 30"-high cladding attaches to the aisle side of a center wall frame's lower zone. It has a painted or veneer surface. Attachment clips are included.

### Notes

Specify width of cladding to match width of center wall frame.

Painted cladding includes 2 cutouts along bottom edge for floor power entry.

### Dimensions

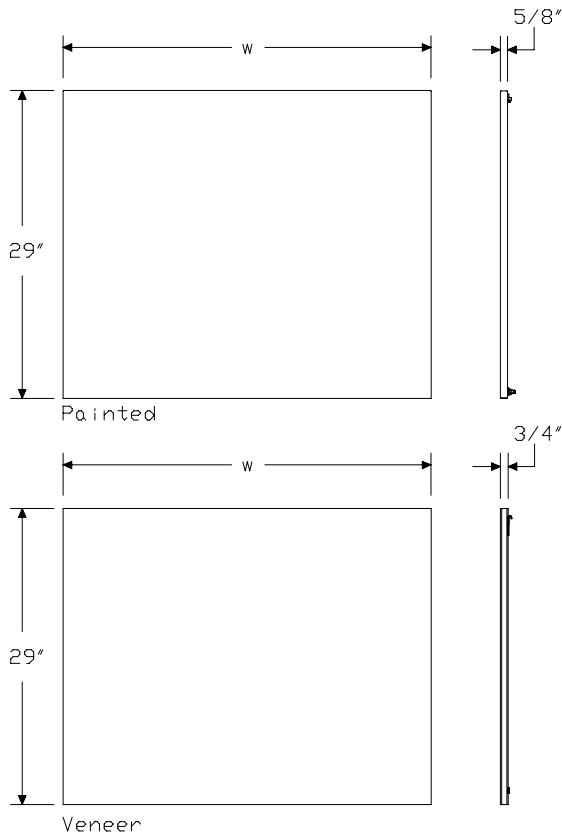

## Specification Information

### Step 1.

**NT142.**  A

### Step 2. Width

**36** 36" wide  A

**48** 48" wide  A

### Step 3. Surface Material

**P** painted  A

**W** veneer  A

### Prices for Steps 1-3.

	P	W
<b>NT142. 36</b>	\$188	304
<b>48</b>	\$248	349

### Step 4. Surface Finish

#### Sand Texture Paint

##### For painted (P)

<b>7L</b>	dune <input type="checkbox"/> A	+\$0
<b>7M</b>	chai <input type="checkbox"/> A	+\$0
<b>7N</b>	grass <input type="checkbox"/> A	+\$0
<b>7U</b>	blue ridge <input type="checkbox"/> A	+\$0
<b>7V</b>	loden <input type="checkbox"/> A	+\$0
<b>7W</b>	napa <input type="checkbox"/> A	+\$0
<b>7Y</b>	sedona <input type="checkbox"/> A	+\$0
<b>7Z</b>	mink <input type="checkbox"/> A	+\$0
<b>8T</b>	gull <input type="checkbox"/> A	+\$0
<b>8Y</b>	moonbeam <input type="checkbox"/> A	+\$0
<b>B4</b>	blue medium <input type="checkbox"/> A	+\$0
<b>ZK</b>	cappuccino <input type="checkbox"/> A	+\$0

#### Bright Sand Texture Paint

##### For painted (P)

<b>91</b>	white <input type="checkbox"/> A	+\$0
<b>CL</b>	cool grey neutral <input type="checkbox"/> A	+\$0
<b>G1</b>	graphite <input type="checkbox"/> A	+\$0
<b>WN</b>	warm grey neutral <input type="checkbox"/> A	+\$0

## Center Wall Aisle Cladding *continued*

---

### Wood Veneer

*For veneer (W)*

---

<b>2U</b>	light brown walnut <input type="checkbox"/> A	+\$0
<b>3U</b>	medium red cherry <input type="checkbox"/> A	+\$0
<b>6U</b>	chocolate brown sapele <input type="checkbox"/> A	+\$0
<b>ED</b>	aged cherry <input type="checkbox"/> A	+\$0
<b>EY</b>	light anigre <input type="checkbox"/> A	+\$0
<b>UL</b>	natural maple <input type="checkbox"/> A	+\$0
<b>UX</b>	walnut on cherry <input type="checkbox"/> A	+\$0

# Center Wall Display Zone Cladding

NT143.

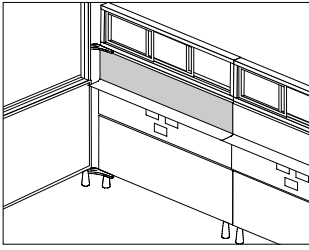

My Studio Environments™ Infrastructure

## Product Information

### Description

This 11"-high cladding attaches to the center wall frame's display zone (above the power/data cladding) and sits in the groove of the inside or outside ledge. It has a painted, tackable fabric, or marker board surface with an aluminum top edge. The painted cladding is magnetic steel; the marker board is white acrylic. Attachment clips are included.

### Notes

Specify width of cladding to match width of center wall frame.  
 Order inside ledge (NT117.) or outside ledge (NT118.) separately.  
 Fabric cladding accepts Customer's Own Material (COM). For directional, 54"-wide fabrics, order minimum of .42 yards. For information on multiple quantities or nondirectional fabrics, contact COM Department.  
 See Order Information in Appendices.

### Dimensions

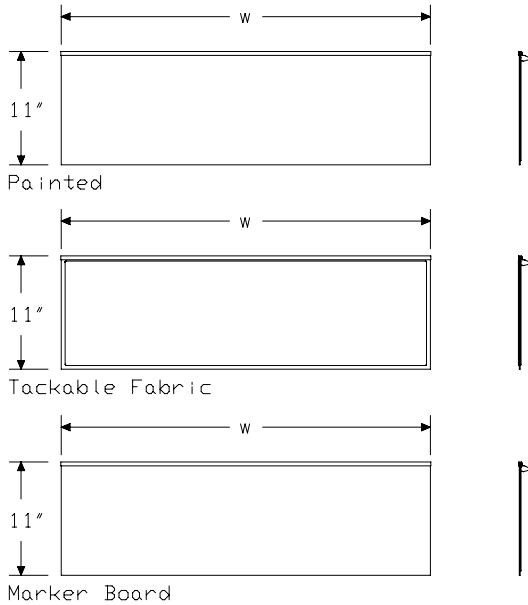

## Specification Information

### Step 1.

**NT143.**

### Step 2. Width

**36** 36" wide   
**48** 48" wide

### Step 3. Surface Material

**P** painted   
**T** tackable fabric   
**M** marker board

### Prices for Steps 1-3.

	P	T	M
<b>NT143. 36</b>	\$90	131	135
<b>48</b>	\$109	146	150

### Step 4. Surface Finish

#### Sand Texture Paint

##### For painted (P)

<b>7L</b>	dune <input type="checkbox"/>	+\$0
<b>7M</b>	chai <input type="checkbox"/>	+\$0
<b>7N</b>	grass <input type="checkbox"/>	+\$0
<b>7U</b>	blue ridge <input type="checkbox"/>	+\$0
<b>7V</b>	loden <input type="checkbox"/>	+\$0
<b>7W</b>	napa <input type="checkbox"/>	+\$0
<b>7Y</b>	sedona <input type="checkbox"/>	+\$0
<b>7Z</b>	mink <input type="checkbox"/>	+\$0
<b>8T</b>	gull <input type="checkbox"/>	+\$0
<b>8Y</b>	moonbeam <input type="checkbox"/>	+\$0
<b>B4</b>	blue medium <input type="checkbox"/>	+\$0
<b>ZK</b>	cappuccino <input type="checkbox"/>	+\$0

#### Bright Sand Texture Paint

##### For painted (P)

<b>91</b>	white <input type="checkbox"/>	+\$0
<b>CL</b>	cool grey neutral <input type="checkbox"/>	+\$0
<b>G1</b>	graphite <input type="checkbox"/>	+\$0
<b>WN</b>	warm grey neutral <input type="checkbox"/>	+\$0

##### For tackable fabric (T)

Price Category 1	+\$0
------------------	------

# Transom Shutter

NT144.

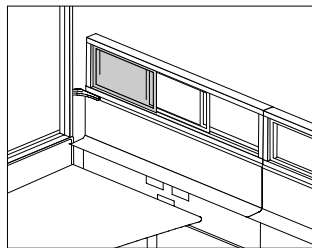

### Product Information

#### Description

This 10<sup>1</sup>/<sub>4</sub>"-high × 17<sup>1</sup>/<sub>2</sub>"-wide glass shutter sits in the track of a center wall transom. It slides along the track to provide privacy or collaboration through the center wall. The <sup>1</sup>/<sub>4</sub>"-wide plastic shutter frame has an integrated molded plastic handle.

#### Notes

For 36"-wide center wall, specify 2 shutters (shutters overlap by <sup>1</sup>/<sub>4</sub>"). For 48"-wide center wall, specify 3 shutters (shutters overlap by 3").

#### Dimensions

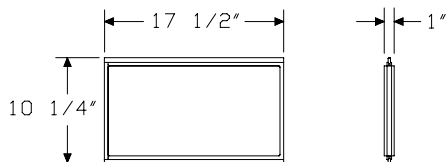

### Specification Information

#### Step 1.

**NT144.11G** [A] \$29

#### Step 2. Glass Finish

<b>34</b>	opal glaze [A]	+\$0
<b>36</b>	bronze glaze [A]	+\$0
<b>54</b>	opal mosaic [A]	+\$0
<b>56</b>	bronze mosaic [A]	+\$0

#### Step 3. Frame Finish

<b>CL</b>	cool grey neutral [A]	+\$0
<b>WN</b>	warm grey neutral [A]	+\$0

# Side Wall Cladding

NT150.

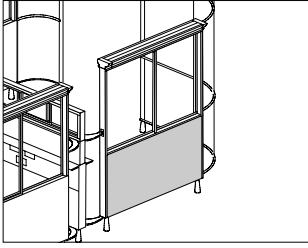

My Studio Environments™ Infrastructure

## Product Information

### Description

This 27"-high cladding attaches to 1 side of a side wall frame's lower zone. It has a painted or veneer surface. Attachment clips are included.

### Notes

Specify width of cladding to match width of side wall frame.

### Dimensions

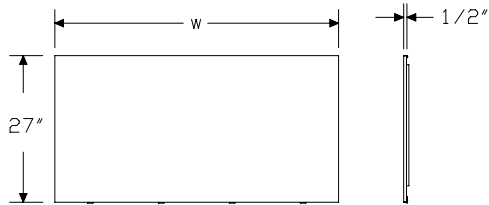

Painted

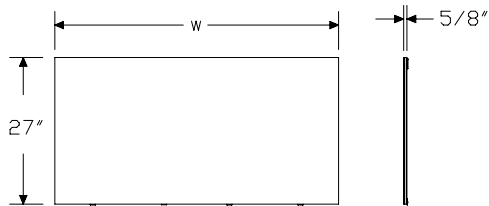

Veneer

## Specification Information

### Step 1.

**NT150.**  A

### Step 2. Width

**54** 54" wide  A

**78** 78" wide  A

### Step 3. Surface Material

**P** painted  A

**W** veneer  A

### Prices for Steps 1-3.

	P	W
<b>NT150. 54</b>	\$132	550
<b>78</b>	\$194	648

### Step 4. Surface Finish

#### Sand Texture Paint

##### For painted (P)

<b>7L</b>	dune <input type="checkbox"/> A	+\$0
<b>7M</b>	chai <input type="checkbox"/> A	+\$0
<b>7N</b>	grass <input type="checkbox"/> A	+\$0
<b>7U</b>	blue ridge <input type="checkbox"/> A	+\$0
<b>7V</b>	loden <input type="checkbox"/> A	+\$0
<b>7W</b>	napa <input type="checkbox"/> A	+\$0
<b>7Y</b>	sedona <input type="checkbox"/> A	+\$0
<b>7Z</b>	mink <input type="checkbox"/> A	+\$0
<b>8T</b>	gull <input type="checkbox"/> A	+\$0
<b>8Y</b>	moonbeam <input type="checkbox"/> A	+\$0
<b>B4</b>	blue medium <input type="checkbox"/> A	+\$0
<b>ZK</b>	cappuccino <input type="checkbox"/> A	+\$0

#### Bright Sand Texture Paint

##### For painted (P)

<b>91</b>	white <input type="checkbox"/> A	+\$0
<b>CL</b>	cool grey neutral <input type="checkbox"/> A	+\$0
<b>G1</b>	graphite <input type="checkbox"/> A	+\$0
<b>WN</b>	warm grey neutral <input type="checkbox"/> A	+\$0

## Side Wall Cladding *continued*

---

### Wood Veneer

*For veneer (W)*

<b>2U</b>	light brown walnut <input type="checkbox"/>	+\$0
<b>3U</b>	medium red cherry <input type="checkbox"/>	+\$0
<b>6U</b>	chocolate brown sapele <input type="checkbox"/>	+\$0
<b>ED</b>	aged cherry <input type="checkbox"/>	+\$0
<b>EY</b>	light anigre <input type="checkbox"/>	+\$0
<b>UL</b>	natural maple <input type="checkbox"/>	+\$0
<b>UX</b>	walnut on cherry <input type="checkbox"/>	+\$0

# Side Wall Shutter

NT152.

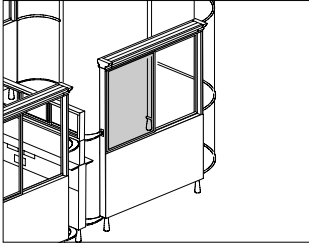

My Studio Environments™ Infrastructure

## Product Information

### Description

This glass shutter sits in the track of a side wall's center rail and is supported by the top rail. It slides along the track to provide privacy or collaboration through the side wall. 2 shutters can be used per side wall frame. The 3/4"-wide plastic shutter frame has an integrated molded plastic handle.

### Notes

Specify shutter height as follows:

- 11"-high shutter for 46"-high side wall
- 33"-high shutter for 68"-high side wall

Actual shutter widths are:

Frame Width—Shutter Width

54"-wide side wall—26 1/2" wide

78"-wide side wall—38 1/2" wide

## Dimensions

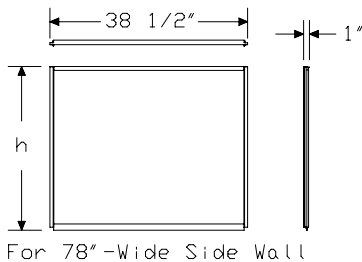
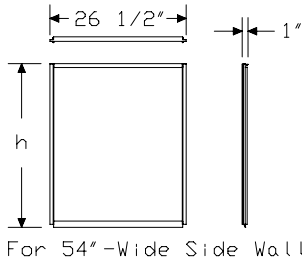

## Specification Information

### Step 1.

**NT152.**  A

### Step 2. Height

**11** 11" high  A

**33** 33" high  A

### Step 3. Usage

**54G** for 54"-wide side wall  A

**78G** for 78"-wide side wall  A

### Prices for Steps 1-3.

	<b>54G</b>	<b>78G</b>
<b>NT152. 11</b>	\$86	96
<b>33</b>	\$116	136

### Step 4. Glass Finish

**34** opal glaze  A +\$0

**36** bronze glaze  A +\$0

**54** opal mosaic  A +\$0

**56** bronze mosaic  A +\$0

### Step 5. Frame Finish

**CL** cool grey neutral  A +\$0

**WN** warm grey neutral  A +\$0

# Streetside Curved Lower Cladding

NT160.

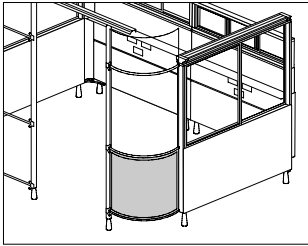

### Product Information

#### Description

This 30"-high cladding attaches to a streetside curved frame's lower zone. It has a painted or glass surface.

#### Notes

Glass cladding has a plastic frame that is  $\frac{3}{8}$ "-wide on the horizontal sides and  $\frac{1}{2}$ "-wide on the vertical sides.

#### Dimensions

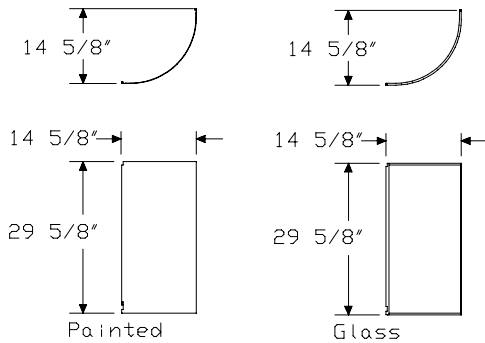

### Specification Information

#### Step 1.

**NT160.**  A

#### Step 2. Surface Material

**P** painted  A

**G** glass  A

#### Prices for Steps 1-2.

<b>NT160. P</b>	\$56
<b>G</b>	\$226

#### Step 3. Surface Finish

##### For painted (P)

<b>91</b>	white <input type="checkbox"/> A	+\$0
<b>CL</b>	cool grey neutral <input type="checkbox"/> A	+\$0
<b>CN</b>	metallic champagne <input type="checkbox"/> A	+\$0
<b>EH</b>	metallic bronze <input type="checkbox"/> A	+\$0
<b>G1</b>	graphite <input type="checkbox"/> A	+\$0
<b>MS</b>	metallic silver <input type="checkbox"/> A	+\$0
<b>WN</b>	warm grey neutral <input type="checkbox"/> A	+\$0

##### For glass (G)

<b>34</b>	opal glaze <input type="checkbox"/> A	+\$0
<b>36</b>	bronze glaze <input type="checkbox"/> A	+\$0

#### Step 4. Frame Finish

##### For glass (G)

<b>CL</b>	cool grey neutral <input type="checkbox"/> A	+\$0
<b>WN</b>	warm grey neutral <input type="checkbox"/> A	+\$0

# Streetside Curved Upper Cladding

NT161.

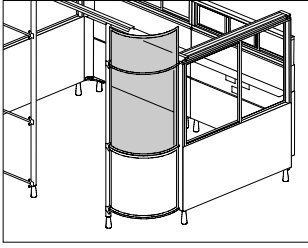

My Studio Environments™ Infrastructure

## Product Information

### Description

This cladding attaches to a streetside curved frame's upper zone. It has a painted or glass surface.

### Notes

Specify height as follows:

- 34"-high cladding for upper zone on 68"- or 81"-high streetside curved frame

- 47"-high cladding for upper zone on 81"-high streetside curved frame

Glass cladding has a plastic frame that is 3/8"-wide on the horizontal sides and 1/2"-wide on the vertical sides.

Painted cladding has a plastic trim piece to align properly with painted streetside curved lower cladding.

When painted curved upper cladding is specified, curved lower cladding must also be specified as painted.

## Dimensions

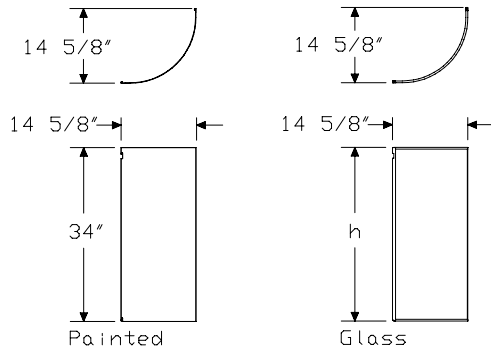

## Specification Information

### Step 1.

**NT161.**  A

### Step 2. Height

**34** 34" high  A

**47** 47" high  A

### Step 3. Surface Material

#### For 34" high (34)

**P** painted  A

**G** glass  A

#### For 47" high (47)

**G** glass  A

### Prices for Steps 1-3.

	P	G
<b>NT161. 34</b>	\$65	245
<b>47</b>	—	\$259

### Step 4. Surface Finish

#### For painted (P)

<b>91</b>	white <input type="checkbox"/> A	+\$0
<b>CL</b>	cool grey neutral <input type="checkbox"/> A	+\$0
<b>CN</b>	metallic champagne <input type="checkbox"/> A	+\$0
<b>EH</b>	metallic bronze <input type="checkbox"/> A	+\$0
<b>G1</b>	graphite <input type="checkbox"/> A	+\$0
<b>MS</b>	metallic silver <input type="checkbox"/> A	+\$0
<b>WN</b>	warm grey neutral <input type="checkbox"/> A	+\$0

#### For glass (G)

<b>34</b>	opal glaze <input type="checkbox"/> A	+\$0
<b>36</b>	bronze glaze <input type="checkbox"/> A	+\$0
<b>54</b>	opal mosaic <input type="checkbox"/> A	+\$0
<b>56</b>	bronze mosaic <input type="checkbox"/> A	+\$0

### Step 5.

#### Trim Finish

#### For painted (P)

<b>CL</b>	cool grey neutral <input type="checkbox"/> A	+\$0
<b>WN</b>	warm grey neutral <input type="checkbox"/> A	+\$0

# Streetside Curved Upper Cladding

*continued*

---

Frame Finish

*For glass (G)*

---

<b>CL</b>	cool grey neutral	<input type="checkbox"/>	A	+\$0
<b>WN</b>	warm grey neutral	<input type="checkbox"/>	A	+\$0

# Streetside Straight Lower Cladding

NT162.

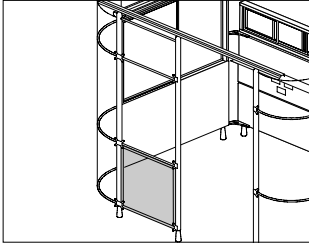

My Studio Environments™ Infrastructure

## Product Information

### Description

This 30"-high cladding attaches to a streetside straight frame's lower zone. It has a painted or glass surface.

### Notes

Specify width of cladding to match width of streetside straight frame.  
Glass cladding has a plastic frame that is  $\frac{3}{8}$ "-wide on the horizontal sides and  $\frac{1}{2}$ "-wide on the vertical sides.

### Dimensions

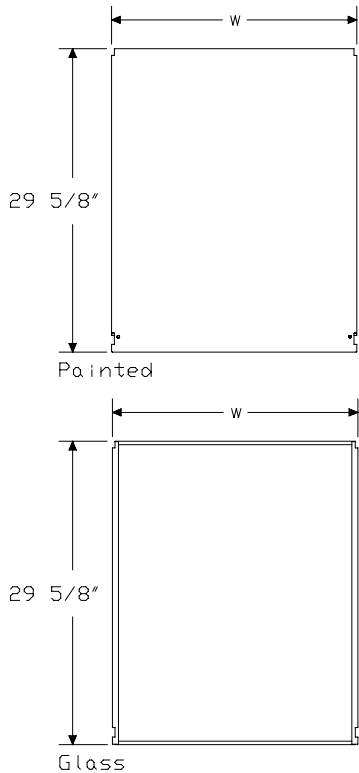

## Specification Information

### Step 1.

**NT162.**  A

### Step 2. Width

**24** 24" wide  A

**28** 28" wide  A

### Step 3. Surface Material

**P** painted  A

**G** glass  A

### Prices for Steps 1-3.

	P	G
<b>NT162. 24</b>	\$45	75
<b>28</b>	\$47	89

### Step 4. Surface Finish

#### For painted (P)

<b>91</b>	white <input type="checkbox"/> A	+\$0
<b>CL</b>	cool grey neutral <input type="checkbox"/> A	+\$0
<b>CN</b>	metallic champagne <input type="checkbox"/> A	+\$0
<b>EH</b>	metallic bronze <input type="checkbox"/> A	+\$0
<b>G1</b>	graphite <input type="checkbox"/> A	+\$0
<b>MS</b>	metallic silver <input type="checkbox"/> A	+\$0
<b>WN</b>	warm grey neutral <input type="checkbox"/> A	+\$0

#### For glass (G)

<b>34</b>	opal glaze <input type="checkbox"/> A	+\$0
<b>36</b>	bronze glaze <input type="checkbox"/> A	+\$0

### Step 5. Frame Finish

#### For glass (G)

<b>CL</b>	cool grey neutral <input type="checkbox"/> A	+\$0
<b>WN</b>	warm grey neutral <input type="checkbox"/> A	+\$0

# Streetside Straight Upper Cladding

NT163.

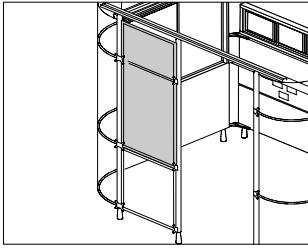

### Product Information

#### Description

This glass cladding attaches to a streetside straight frame's upper zone. It has a plastic frame that is 3/8"-wide on the horizontal sides and 1/2"-wide on the vertical sides.

#### Notes

Specify height as follows:

- 34"-high cladding for upper zone on 68"- or 81"-high streetside straight frame
  - 47"-high cladding for upper zone on 81"-high streetside straight frame
- Specify width of cladding to match width of streetside straight frame.

#### Dimensions

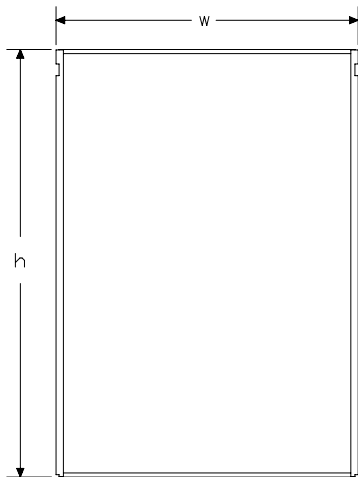

### Specification Information

#### Step 1.

**NT163.**  A

#### Step 2. Height

**34** 34" high  A

**47** 47" high  A

#### Step 3. Width

**24G** 24" wide  A

**28G** 28" wide  A

#### Prices for Steps 1-3.

	<b>24G</b>	<b>28G</b>
<b>NT163. 34</b>	\$113	119
<b>47</b>	\$141	151

#### Step 4. Glass Finish

**34** opal glaze  A +\$0

**36** bronze glaze  A +\$0

**54** opal mosaic  A +\$0

**56** bronze mosaic  A +\$0

#### Step 5. Frame Finish

**CL** cool grey neutral  A +\$0

**WN** warm grey neutral  A +\$0

# Streetside Curved Monolithic Cladding

NT164.

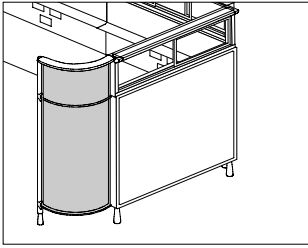

My Studio Environments™ Infrastructure

## Product Information

**Description**  
This 42"-high cladding attaches to a 46"-high streetside curved frame. It has a painted or glass surface.

**Notes**  
Glass cladding has a plastic frame that is 3/8"-wide on the horizontal sides and 1/2"-wide on the vertical sides.

## Dimensions

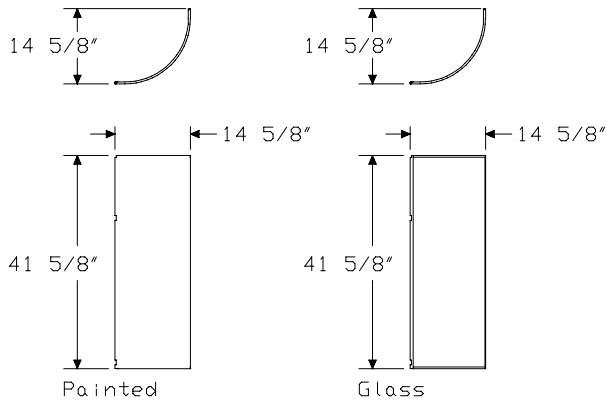

## Specification Information

### Step 1.

**NT164.42**  A

### Step 2. Surface Material

- P** painted  A
- G** glass  A

### Prices for Steps 1-2.

<b>NT164.42 P</b>	\$76
<b>G</b>	\$239

### Step 3. Surface Finish

#### For painted (P)

<b>91</b>	white <input type="checkbox"/> A	+\$0
<b>CL</b>	cool grey neutral <input type="checkbox"/> A	+\$0
<b>CN</b>	metallic champagne <input type="checkbox"/> A	+\$0
<b>EH</b>	metallic bronze <input type="checkbox"/> A	+\$0
<b>G1</b>	graphite <input type="checkbox"/> A	+\$0
<b>MS</b>	metallic silver <input type="checkbox"/> A	+\$0
<b>WN</b>	warm grey neutral <input type="checkbox"/> A	+\$0

#### For glass (G)

<b>34</b>	opal glaze <input type="checkbox"/> A	+\$0
<b>36</b>	bronze glaze <input type="checkbox"/> A	+\$0

### Step 4. Frame Finish

#### For glass (G)

<b>CL</b>	cool grey neutral <input type="checkbox"/> A	+\$0
<b>WN</b>	warm grey neutral <input type="checkbox"/> A	+\$0

# Streetside Straight Monolithic Cladding

NT165.

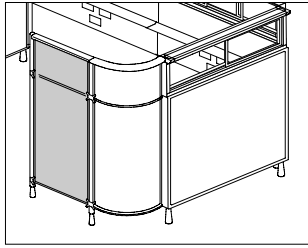

## Product Information

### Description

This 42"-high cladding attaches to a 46"-high streetside straight frame. It has a painted or glass surface.

### Notes

Specify width of cladding to match width of streetside straight frame.

Glass cladding has a plastic frame that is  $\frac{3}{8}$ "-wide on the horizontal sides and  $\frac{1}{2}$ "-wide on the vertical sides.

### Dimensions

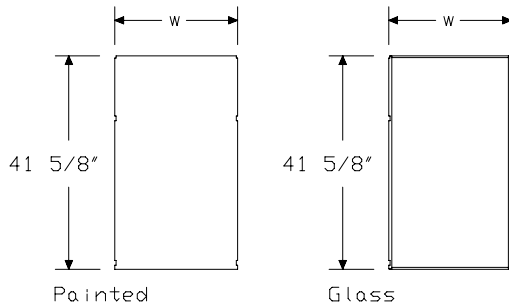

## Specification Information

### Step 1.

**NT165.42**  A

### Step 2. Width

**24** 24" wide  A

**28** 28" wide  A

### Step 3. Surface Material

**P** painted  A

**G** glass  A

### Prices for Steps 1-3.

		P	G
<b>NT165.42</b>	<b>24</b>	\$65	131
	<b>28</b>	\$67	136

### Step 4. Surface Finish

#### For painted (P)

<b>91</b>	white <input type="checkbox"/> A	+\$0
<b>CL</b>	cool grey neutral <input type="checkbox"/> A	+\$0
<b>CN</b>	metallic champagne <input type="checkbox"/> A	+\$0
<b>EH</b>	metallic bronze <input type="checkbox"/> A	+\$0
<b>G1</b>	graphite <input type="checkbox"/> A	+\$0
<b>MS</b>	metallic silver <input type="checkbox"/> A	+\$0
<b>WN</b>	warm grey neutral <input type="checkbox"/> A	+\$0

#### For glass (G)

<b>34</b>	opal glaze <input type="checkbox"/> A	+\$0
<b>36</b>	bronze glaze <input type="checkbox"/> A	+\$0

### Step 5. Frame Finish

#### For glass (G)

<b>CL</b>	cool grey neutral <input type="checkbox"/> A	+\$0
<b>WN</b>	warm grey neutral <input type="checkbox"/> A	+\$0

# Concave Primary Surface

NT220.

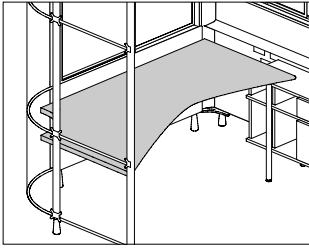

My Studio Environments™ Work Surfaces

## Product Information

### Description

This surface is positioned along a side wall and is supported by a primary surface support and a bookcase leg or support leg. It has a laminate, formcoat®, or veneer top. The laminate and veneer top surfaces have vinyl side and back edges and a vinyl profile front edge. The surface has a height range of 26½" to 31½". There is a 1" gap at the back of the surface for standard plug head and cord passage.

The surface has predrilled holes for attaching the primary surface support, power/data distributor, and surface trough. A 6½" cutout in the streetside corner accepts the power/data distributor; distributor attaches to the underside of the surface.

The solid-color laminate surfaces have vinyl side and back edges that match the specified laminate surface finish; profile front edge finish is specified separately. The zephyr laminate surfaces have predetermined vinyl side and back edge colors (see chart); profile front edge finish is specified separately. The veneer surfaces have vinyl side and back edges that match the specified vinyl profile front edge finish.

The formcoat finish is available as opaque or fleck. The opaque finish is nontransparent and has a solid-color appearance; the fleck finish is a nontransparent solid color with tiny flecks.

Zephyr laminate side and back edge colors are predetermined:

- Top Color—Side and Back Edge Color
- Canyon (D1)—Warm Grey Neutral (WN)
- Misted (DC)—Cool Grey Neutral (CL)
- Twilight (DF)—Graphite Satin (G2)
- Desert (DQ)—Warm Grey Neutral (WN)

### Notes

For additional edges, finishes, or gaps at back of surface, see Vary Easy® Program in Appendices.

For nonstandard formcoat paint colors, see Customer's Own Formcoat® Program in Appendices.

Specify surface depth as follows:

- Depth—Streetside Straight Frame
- 38" deep (streetside)—24" wide
- 42" deep (streetside)—28" wide

Larger depth of surface is on streetside of office.

Specify depth as 38 or 30 for 6'×6' offices. Specify depth as 42 or 34 for 6'×8' and 8'×8' offices. For more information, see My Studio Environments™ Planning Guide.

Specify surface width as follows:

- Width—Side Wall Frame
- 72" wide—54" wide
- 96" wide—78" wide

Order primary surface support (NT290.) separately.

When bookcase is not used, order support leg (NT291.) separately. For additional information on surface and bookcase planning, see My Studio Environments Planning Guide.

Order optional energy distribution products separately:

- Power/data distributor (NT171.)
- Surface trough (NT172.)

Storage products and accessory products cannot attach to underside of surface.

For attached keyboard support, keyboard track adapter (Y7793.) must be specified with 1 of the following:

- Adjustable keyboard/mouse support (Y7710.)
- Fully adjustable keyboard/mouse support (Y7727.)

For freestanding keyboard support, order 1 of the following:

- Scooter® stand with input device (Y7708.)
- Scooter stand with wood top (Y7706.)

## Dimensions

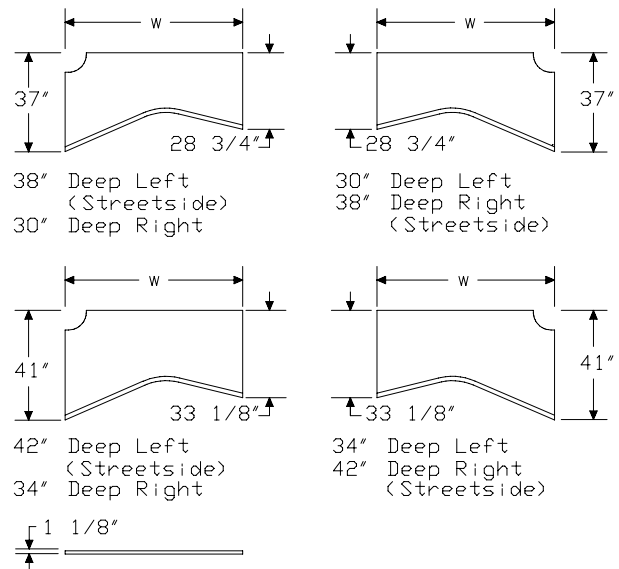

Concave Primary Surface *continued*

**Specification Information**

Step 1.

**NT220.** A

Step 2. Depth

<b>38</b>	38" deep left (streetside), 30" deep right	<span style="border: 1px solid black; padding: 0 2px;">A</span>
<b>30</b>	30" deep left, 38" deep right (streetside)	<span style="border: 1px solid black; padding: 0 2px;">A</span>
<b>42</b>	42" deep left (streetside), 34" deep right	<span style="border: 1px solid black; padding: 0 2px;">A</span>
<b>34</b>	34" deep left, 42" deep right (streetside)	<span style="border: 1px solid black; padding: 0 2px;">A</span>

Step 3. Width

<b>72</b>	72" wide	<span style="border: 1px solid black; padding: 0 2px;">A</span>
<b>96</b>	96" wide	<span style="border: 1px solid black; padding: 0 2px;">A</span>

Step 4. Surface Material

<b>L</b>	laminate	<span style="border: 1px solid black; padding: 0 2px;">A</span>
<b>W</b>	veneer	<span style="border: 1px solid black; padding: 0 2px;">A</span>
<b>T</b>	formcoat®	<span style="border: 1px solid black; padding: 0 2px;">A</span>

Prices for Steps 1-4.

	<b>L</b>	<b>W</b>	<b>T</b>
<b>NT220. 38 72</b>	\$456	895	776
<b>96</b>	\$576	1050	980
<b>30 72</b>	\$456	895	776
<b>96</b>	\$576	1050	980
<b>42 72</b>	\$476	905	810
<b>96</b>	\$596	1106	1014
<b>34 72</b>	\$476	905	810
<b>96</b>	\$596	1106	1014

Step 5. Top Finish

Solid-Color Laminate

*For laminate (L)*

<b>8Q</b>	folkstone grey	<span style="border: 1px solid black; padding: 0 2px;">A</span>	+\$0
<b>91</b>	white	<span style="border: 1px solid black; padding: 0 2px;">A</span>	+\$0
<b>CL</b>	cool grey neutral	<span style="border: 1px solid black; padding: 0 2px;">A</span>	+\$0
<b>LU</b>	soft white	<span style="border: 1px solid black; padding: 0 2px;">A</span>	+\$0
<b>WL</b>	sandstone	<span style="border: 1px solid black; padding: 0 2px;">A</span>	+\$0
<b>WN</b>	warm grey neutral	<span style="border: 1px solid black; padding: 0 2px;">A</span>	+\$0

Zephyr Laminate

*For laminate (L)*

<b>D1</b>	canyon	<span style="border: 1px solid black; padding: 0 2px;">A</span>	+\$0
<b>DC</b>	misted	<span style="border: 1px solid black; padding: 0 2px;">A</span>	+\$0
<b>DF</b>	twilight	<span style="border: 1px solid black; padding: 0 2px;">A</span>	+\$0
<b>DQ</b>	desert	<span style="border: 1px solid black; padding: 0 2px;">A</span>	+\$0

Wood Veneer

*For veneer (W)*

<b>2U</b>	light brown walnut	<span style="border: 1px solid black; padding: 0 2px;">A</span>	+\$0
<b>3U</b>	medium red cherry	<span style="border: 1px solid black; padding: 0 2px;">A</span>	+\$0
<b>6U</b>	chocolate brown sapele	<span style="border: 1px solid black; padding: 0 2px;">A</span>	+\$0
<b>ED</b>	aged cherry	<span style="border: 1px solid black; padding: 0 2px;">A</span>	+\$0
<b>EY</b>	light anigre	<span style="border: 1px solid black; padding: 0 2px;">A</span>	+\$0
<b>UL</b>	natural maple	<span style="border: 1px solid black; padding: 0 2px;">A</span>	+\$0
<b>UX</b>	walnut on cherry	<span style="border: 1px solid black; padding: 0 2px;">A</span>	+\$0

Opaque Formcoat®

*For formcoat® (T)*

<b>8Q</b>	folkstone grey	<span style="border: 1px solid black; padding: 0 2px;">A</span>	+\$0
<b>91</b>	white	<span style="border: 1px solid black; padding: 0 2px;">A</span>	+\$0
<b>CL</b>	cool grey neutral	<span style="border: 1px solid black; padding: 0 2px;">A</span>	+\$0
<b>LU</b>	soft white	<span style="border: 1px solid black; padding: 0 2px;">A</span>	+\$0
<b>WL</b>	sandstone	<span style="border: 1px solid black; padding: 0 2px;">A</span>	+\$0
<b>WN</b>	warm grey neutral	<span style="border: 1px solid black; padding: 0 2px;">A</span>	+\$0
<b>X1</b>	chalk white	<span style="border: 1px solid black; padding: 0 2px;">A</span>	+\$0

Fleck Formcoat®

*For formcoat® (T)*

<b>7F</b>	natural maple fleck	<span style="border: 1px solid black; padding: 0 2px;">A</span>	+\$40
<b>7G</b>	light anigre fleck	<span style="border: 1px solid black; padding: 0 2px;">A</span>	+\$40
<b>7H</b>	aged cherry fleck	<span style="border: 1px solid black; padding: 0 2px;">A</span>	+\$40

Step 6. Profile Edge Finish

*For laminate (L) or veneer (W)*

<b>CL</b>	cool grey neutral	<span style="border: 1px solid black; padding: 0 2px;">A</span>	+\$0
<b>G2</b>	graphite satin	<span style="border: 1px solid black; padding: 0 2px;">A</span>	+\$0
<b>WN</b>	warm grey neutral	<span style="border: 1px solid black; padding: 0 2px;">A</span>	+\$0

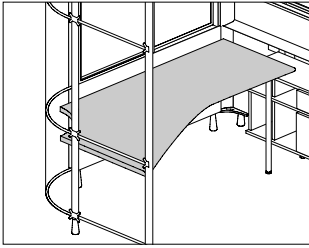

**Product Information**

**Description**

This surface is positioned along a side wall and is supported by a primary surface support and a bookcase leg or support leg. It has a laminate, formcoat®, or veneer top. The laminate and veneer top surfaces have vinyl side and back edges and a vinyl profile front edge. The surface has a height range of 26 1/2" to 31 1/2". There is a 1" gap at the back of the surface for standard plug head and cord passage.

The surface has predrilled holes for attaching the primary surface support, power/data distributor, and surface trough. A 6 1/2" cutout in the streetside corner accepts the power/data distributor; distributor attaches to the underside of the surface.

The solid-color laminate surfaces have vinyl side and back edges that match the specified laminate surface finish; profile front edge finish is specified separately. The zephyr laminate surfaces have predetermined vinyl side and back edge colors (see chart); profile front edge finish is specified separately. The veneer surfaces have vinyl side and back edges that match the specified vinyl profile front edge finish.

The formcoat finish is available as opaque or fleck. The opaque finish is nontransparent and has a solid-color appearance; the fleck finish is a nontransparent solid color with tiny flecks.

Zephyr laminate side and back edge colors are predetermined:

- Top Color—Side and Back Edge Color
- Canyon (D1)—Warm Grey Neutral (WN)
- Misted (DC)—Cool Grey Neutral (CL)
- Twilight (DF)—Graphite Satin (G2)
- Desert (DQ)—Warm Grey Neutral (WN)

**Notes**

For additional edges, finishes, or gaps at back of surface, see Vary Easy® Program in Appendices.

For nonstandard formcoat paint colors, see Customer's Own Formcoat® Program in Appendices.

Specify surface depth as follows:

- Depth—Streetside Straight Frame
- 38" deep (streetside)—24" wide
- 42" deep (streetside)—28" wide

Larger depth of surface is on streetside of office.

Specify depth as 38 or 23 for 6'x6' offices. Specify depth as 42 or 28 for 6'x8' and 8'x8' offices. For more information, see My Studio Environments™ Planning Guide.

Specify surface width as follows:

- Width—Side Wall Frame
- 72" wide—54" wide
- 96" wide—78" wide

Order primary surface support (NT290.) separately.

When bookcase is not used, order support leg (NT291.) separately. For additional information on surface and bookcase planning, see My Studio Environments Planning Guide.

Order optional energy distribution products separately:

- Power/data distributor (NT171.)
- Surface trough (NT172.)

Storage products and accessory products cannot attach to underside of surface.

For attached keyboard support, keyboard track adapter (Y7793.) must be specified with 1 of the following:

- Adjustable keyboard/mouse support (Y7710.)
- Fully adjustable keyboard/mouse support (Y7727.)

For freestanding keyboard support, order 1 of the following:

- Scooter® stand with input device (Y7708.)
- Scooter stand with wood top (Y7706.)

**Dimensions**

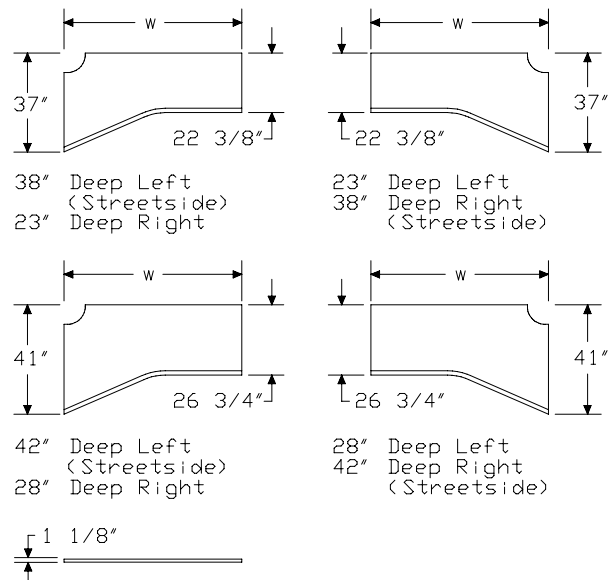

# Winged-End Primary Surface

continued

## Specification Information

### Step 1.

**NT221.**

### Step 2. Depth

<b>38</b>	38" deep left (streetside), 23" deep right	<input type="checkbox"/>
<b>23</b>	23" deep left, 38" deep right (streetside)	<input type="checkbox"/>
<b>42</b>	42" deep left (streetside), 28" deep right	<input type="checkbox"/>
<b>28</b>	28" deep left, 42" deep right (streetside)	<input type="checkbox"/>

### Step 3. Width

<b>72</b>	72" wide	<input type="checkbox"/>
<b>96</b>	96" wide	<input type="checkbox"/>

### Step 4. Surface Material

<b>L</b>	laminate	<input type="checkbox"/>
<b>W</b>	veneer	<input type="checkbox"/>
<b>T</b>	formcoat®	<input type="checkbox"/>

### Prices for Steps 1-4.

	<b>L</b>	<b>W</b>	<b>T</b>
<b>NT221. 38 72</b>	\$436	875	742
<b>96</b>	\$556	1030	946
<b>23 72</b>	\$436	875	742
<b>96</b>	\$556	1030	946
<b>42 72</b>	\$456	885	776
<b>96</b>	\$576	1086	980
<b>28 72</b>	\$456	885	776
<b>96</b>	\$576	1086	980

### Step 5. Top Finish

#### Solid-Color Laminate

For laminate (L)

<b>8Q</b>	folkstone grey	<input type="checkbox"/>	+\$0
<b>91</b>	white	<input type="checkbox"/>	+\$0
<b>CL</b>	cool grey neutral	<input type="checkbox"/>	+\$0
<b>LU</b>	soft white	<input type="checkbox"/>	+\$0
<b>WL</b>	sandstone	<input type="checkbox"/>	+\$0
<b>WN</b>	warm grey neutral	<input type="checkbox"/>	+\$0

#### Zephyr Laminate

For laminate (L)

<b>D1</b>	canyon	<input type="checkbox"/>	+\$0
<b>DC</b>	misted	<input type="checkbox"/>	+\$0
<b>DF</b>	twilight	<input type="checkbox"/>	+\$0
<b>DQ</b>	desert	<input type="checkbox"/>	+\$0

#### Wood Veneer

For veneer (W)

<b>2U</b>	light brown walnut	<input type="checkbox"/>	+\$0
<b>3U</b>	medium red cherry	<input type="checkbox"/>	+\$0
<b>6U</b>	chocolate brown sapele	<input type="checkbox"/>	+\$0
<b>ED</b>	aged cherry	<input type="checkbox"/>	+\$0
<b>EY</b>	light anigre	<input type="checkbox"/>	+\$0
<b>UL</b>	natural maple	<input type="checkbox"/>	+\$0
<b>UX</b>	walnut on cherry	<input type="checkbox"/>	+\$0

#### Opaque Formcoat®

For formcoat® (T)

<b>8Q</b>	folkstone grey	<input type="checkbox"/>	+\$0
<b>91</b>	white	<input type="checkbox"/>	+\$0
<b>CL</b>	cool grey neutral	<input type="checkbox"/>	+\$0
<b>LU</b>	soft white	<input type="checkbox"/>	+\$0
<b>WL</b>	sandstone	<input type="checkbox"/>	+\$0
<b>WN</b>	warm grey neutral	<input type="checkbox"/>	+\$0
<b>X1</b>	chalk white	<input type="checkbox"/>	+\$0

#### Fleck Formcoat®

For formcoat® (T)

<b>7F</b>	natural maple fleck	<input type="checkbox"/>	+\$40
<b>7G</b>	light anigre fleck	<input type="checkbox"/>	+\$40
<b>7H</b>	aged cherry fleck	<input type="checkbox"/>	+\$40

### Step 6. Profile Edge Finish

For laminate (L) or veneer (W)

<b>CL</b>	cool grey neutral	<input type="checkbox"/>	+\$0
<b>G2</b>	graphite satin	<input type="checkbox"/>	+\$0
<b>WN</b>	warm grey neutral	<input type="checkbox"/>	+\$0

# Primary Surface Support

NT290.

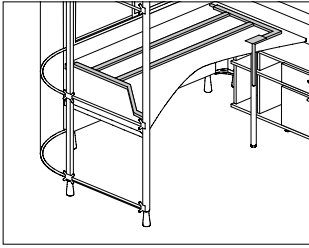

My Studio Environments™ Work Surfaces

## Product Information

### Description

This support attaches to a side wall frame, a streetside straight frame, and the underside of a primary surface. It telescopes to accommodate various primary surface depths. The support has a post that fits into a bookcase leg, bookshelf leg, or support leg. The support places the surface height between 26½" and 31½". Finish is black. Attachment hardware is included.

### Notes

Specify support width as follows:

Support Width—Primary Surface—Side Wall

72" wide—72" wide—54" wide

96" wide—96" wide—78" wide

When bookcase or bookshelf is not used, order support leg (NT291.) separately.

Surface support extends 1" below surface; attaching screw head extends ¼" below support.

## Dimensions

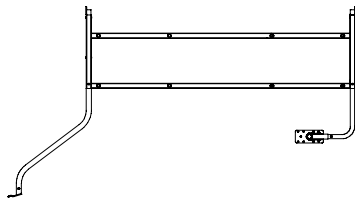
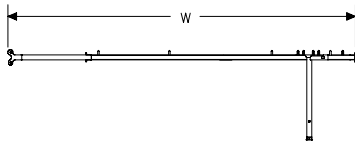

## Specification Information

### Step 1.

**NT290.** A

### Step 2. Width

**72** 72" wide A

**96** 96" wide A

### Prices for Steps 1-2.

<b>NT290. 72</b>	\$218
<b>96</b>	\$236

# Support Leg

NT291.

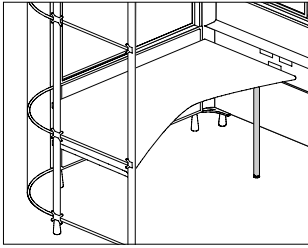

### Product Information

#### Description

This leg supports a primary or secondary surface in applications without a bookcase. The post of the primary or secondary surface support fits into the support leg. It is pin adjustable and has a height range of 26 1/2" to 31 1/2". The leg's leveling glide has 2" of height adjustment.

#### Dimensions

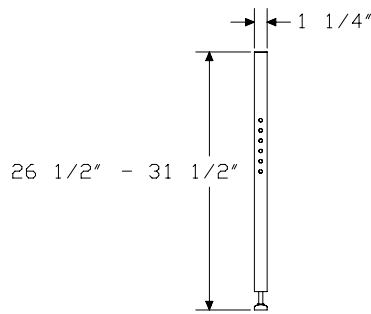

### Specification Information

#### Step 1.

**NT291.**  A \$34

#### Step 2. Finish

**CN** metallic champagne  A +\$0  
**EH** metallic bronze  A +\$0  
**MS** metallic silver  A +\$0

# Winged-End Secondary Surface NT310.

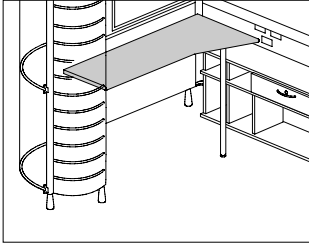

My Studio Environments™ Work Surfaces

## Product Information

### Description

This squared-edge surface sits against a side wall and closet and is supported by a secondary surface support and a bookcase leg or support leg. It has a laminate, formcoat®, or veneer top. The laminate surface has vinyl edges and the veneer surface has veneer edges. The surface has a height range of 26½" to 31½" and predrilled holes for attaching the secondary surface support. There is a 1" gap at the back of the surface for standard plug head and cord passage.

The solid-color laminate surfaces have vinyl edges that match the specified laminate surface finish. The zephyr laminate surfaces have predetermined vinyl edge colors (see chart).

The formcoat finish is available as opaque or fleck. The opaque finish is nontransparent and has a solid-color appearance; the fleck finish is a nontransparent solid color with tiny flecks.

Zephyr laminate edge colors are predetermined:

Top Color—Edge Color

Canyon (D1)—Warm Grey Neutral (WN)

Misted (DC)—Cool Grey Neutral (CL)

Twilight (DF)—Graphite Satin (G2)

Desert (DQ)—Warm Grey Neutral (WN)

### Notes

For additional edges, finishes, or gaps at back of surface, see Vary Easy® Program in Appendices.

For nonstandard formcoat paint colors, see Customer's Own Formcoat® Program in Appendices.

Specify width of surface to match width of side wall frame.

Order secondary surface support (NT390.) separately.

When bookcase is not used, order support leg (NT291.) separately. For additional information on surface and bookcase planning, see My Studio Environments™ Planning Guide.

When closet is not used, order secondary surface end support (NT391.) separately.

Storage products and accessory products cannot attach to underside of surface.

For attached keyboard support, keyboard track adapter (Y7793.) must be specified with 1 of the following:

- Adjustable keyboard/mouse support (Y7710.)
- Fully adjustable keyboard/mouse support (Y7727.)

For freestanding keyboard support, order 1 of the following:

- Scooter® stand with input device (Y7708.)
- Scooter stand with wood top (Y7706.)

## Dimensions

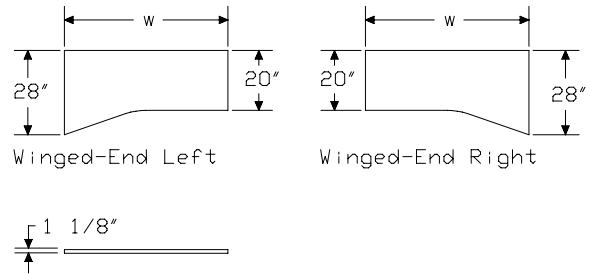

# Winged-End Secondary Surface

continued

My Studio Environments™ Work Surfaces

## Specification Information

### Step 1.

**NT310.**

### Step 2. Width

**54** 54" wide   
**78** 78" wide

### Step 3. Position

**L** winged-end left   
**R** winged-end right

### Step 4. Surface Material

**L** laminate   
**W** veneer   
**T** formcoat®

### Prices for Steps 1-4.

	L	W	T
<b>NT310. 54 L</b>	\$229	697	550
<b>R</b>	\$229	697	550
<b>78 L</b>	\$259	750	622
<b>R</b>	\$259	750	622

### Step 5. Top/Edge Finish

#### Solid-Color Laminate Top/Vinyl Edge

For laminate (L)

<b>8Q</b>	folkstone grey <input type="checkbox"/>	+\$0
<b>91</b>	white <input type="checkbox"/>	+\$0
<b>CL</b>	cool grey neutral <input type="checkbox"/>	+\$0
<b>LU</b>	soft white <input type="checkbox"/>	+\$0
<b>WL</b>	sandstone <input type="checkbox"/>	+\$0
<b>WN</b>	warm grey neutral <input type="checkbox"/>	+\$0

#### Zephyr Laminate Top/Vinyl Edge

For laminate (L)

<b>D1</b>	canyon <input type="checkbox"/>	+\$0
<b>DC</b>	misted <input type="checkbox"/>	+\$0
<b>DF</b>	twilight <input type="checkbox"/>	+\$0
<b>DQ</b>	desert <input type="checkbox"/>	+\$0

#### Wood Veneer

For veneer (W)

<b>2U</b>	light brown walnut <input type="checkbox"/>	+\$0
<b>3U</b>	medium red cherry <input type="checkbox"/>	+\$0
<b>6U</b>	chocolate brown sapele <input type="checkbox"/>	+\$0
<b>ED</b>	aged cherry <input type="checkbox"/>	+\$0
<b>EY</b>	light anigre <input type="checkbox"/>	+\$0
<b>UL</b>	natural maple <input type="checkbox"/>	+\$0
<b>UX</b>	walnut on cherry <input type="checkbox"/>	+\$0

#### Opaque Formcoat®

For formcoat® (T)

<b>8Q</b>	folkstone grey <input type="checkbox"/>	+\$0
<b>91</b>	white <input type="checkbox"/>	+\$0
<b>CL</b>	cool grey neutral <input type="checkbox"/>	+\$0
<b>LU</b>	soft white <input type="checkbox"/>	+\$0
<b>WL</b>	sandstone <input type="checkbox"/>	+\$0
<b>WN</b>	warm grey neutral <input type="checkbox"/>	+\$0
<b>X1</b>	chalk white <input type="checkbox"/>	+\$0

#### Fleck Formcoat®

For formcoat® (T)

<b>7F</b>	natural maple fleck <input type="checkbox"/>	+\$30
<b>7G</b>	light anigre fleck <input type="checkbox"/>	+\$30
<b>7H</b>	aged cherry fleck <input type="checkbox"/>	+\$30

# Rectangular Secondary Surface NT311.

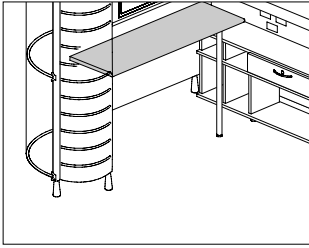

My Studio Environments™ Work Surfaces

## Product Information

### Description

This squared-edge surface sits against a side wall and closet and is supported by a secondary surface support and a bookcase leg or support leg. It has a laminate, formcoat®, or veneer top. The laminate surface has vinyl edges and the veneer surface has veneer edges. The surface has a height range of 26½" to 31½" and predrilled holes for attaching the secondary surface support. There is a 1" gap at the back of the surface for standard plug head and cord passage.

The solid-color laminate surfaces have vinyl edges that match the specified laminate surface finish. The zephyr laminate surfaces have predetermined vinyl edge colors (see chart).

The formcoat finish is available as opaque or fleck. The opaque finish is nontransparent and has a solid-color appearance; the fleck finish is a nontransparent solid color with tiny flecks.

Zephyr laminate edge colors are predetermined:

Top Color—Edge Color

Canyon (D1)—Warm Grey Neutral (WN)

Misted (DC)—Cool Grey Neutral (CL)

Twilight (DF)—Graphite Satin (G2)

Desert (DQ)—Warm Grey Neutral (WN)

### Notes

For additional edges, finishes, or gaps at back of surface, see Vary Easy® Program in Appendices.

For nonstandard formcoat paint colors, see Customer's Own Formcoat® Program in Appendices.

Specify width of surface to match width of side wall frame.

Order secondary surface support (NT390.) separately.

When bookcase is not used, order support leg (NT291.) separately. For additional information on surface and bookcase planning, see My Studio Environments™ Planning Guide.

When closet is not used, order secondary surface end support (NT391.) separately.

Storage products and accessory products cannot attach to underside of surface.

For attached keyboard support, keyboard track adapter (Y7793.) must be specified with 1 of the following:

- Adjustable keyboard/mouse support (Y7710.)
- Fully adjustable keyboard/mouse support (Y7727.)

For freestanding keyboard support, order 1 of the following:

- Scooter® stand with input device (Y7708.)
- Scooter stand with wood top (Y7706.)

## Dimensions

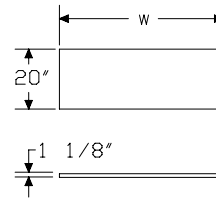

# Rectangular Secondary Surface

continued

## Specification Information

Step 1.

**NT311.**

Step 2. Width

**54** 54" wide

**78** 78" wide

Step 3. Surface Material

**L** laminate

**W** veneer

**T** formcoat®

Prices for Steps 1-3.

	L	W	T
<b>NT311. 54</b>	\$176	520	423
<b>78</b>	\$205	562	493

Step 4. Top/Edge Finish

Solid-Color Laminate Top/Vinyl Edge

For laminate (L)

<b>8Q</b>	folkstone grey <input type="checkbox"/>	+\$0
<b>91</b>	white <input type="checkbox"/>	+\$0
<b>CL</b>	cool grey neutral <input type="checkbox"/>	+\$0
<b>LU</b>	soft white <input type="checkbox"/>	+\$0
<b>WL</b>	sandstone <input type="checkbox"/>	+\$0
<b>WN</b>	warm grey neutral <input type="checkbox"/>	+\$0

Zephyr Laminate Top/Vinyl Edge

For laminate (L)

<b>D1</b>	canyon <input type="checkbox"/>	+\$0
<b>DC</b>	misted <input type="checkbox"/>	+\$0
<b>DF</b>	twilight <input type="checkbox"/>	+\$0
<b>DQ</b>	desert <input type="checkbox"/>	+\$0

Wood Veneer

For veneer (W)

<b>2U</b>	light brown walnut <input type="checkbox"/>	+\$0
<b>3U</b>	medium red cherry <input type="checkbox"/>	+\$0
<b>6U</b>	chocolate brown sapele <input type="checkbox"/>	+\$0
<b>ED</b>	aged cherry <input type="checkbox"/>	+\$0
<b>EY</b>	light anigre <input type="checkbox"/>	+\$0
<b>UL</b>	natural maple <input type="checkbox"/>	+\$0
<b>UX</b>	walnut on cherry <input type="checkbox"/>	+\$0

Opaque Formcoat®

For formcoat® (T)

<b>8Q</b>	folkstone grey <input type="checkbox"/>	+\$0
<b>91</b>	white <input type="checkbox"/>	+\$0
<b>CL</b>	cool grey neutral <input type="checkbox"/>	+\$0
<b>LU</b>	soft white <input type="checkbox"/>	+\$0
<b>WL</b>	sandstone <input type="checkbox"/>	+\$0
<b>WN</b>	warm grey neutral <input type="checkbox"/>	+\$0
<b>X1</b>	chalk white <input type="checkbox"/>	+\$0

Fleck Formcoat®

For formcoat® (T)

<b>7F</b>	natural maple fleck <input type="checkbox"/>	+\$30
<b>7G</b>	light anigre fleck <input type="checkbox"/>	+\$30
<b>7H</b>	aged cherry fleck <input type="checkbox"/>	+\$30

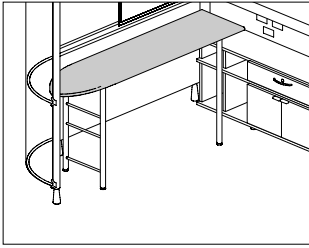

**Product Information**

**Description**

This squared-edge surface is supported by a secondary surface support, secondary surface end support, and a bookcase leg or support leg. The round end fills the space in applications without a closet. It has a laminate, formcoat®, or veneer top. The laminate surface has vinyl edges and the veneer surface has veneer edges. It has a height range of 26½" to 31½" and predrilled holes for attaching the secondary surface support. There is a 1" gap at the back of the surface for standard plug head and cord passage.

The solid-color laminate surfaces have vinyl edges that match the specified laminate surface finish. The zephyr laminate surfaces have predetermined vinyl edge colors (see chart).

The formcoat finish is available as opaque or fleck. The opaque finish is nontransparent and has a solid-color appearance; the fleck finish is a nontransparent solid color with tiny flecks.

Zephyr laminate edge colors are predetermined:

Top Color—Edge Color

Canyon (D1)—Warm Grey Neutral (WN)

Misted (DC)—Cool Grey Neutral (CL)

Twilight (DF)—Graphite Satin (G2)

Desert (DQ)—Warm Grey Neutral (WN)

**Notes**

For additional edges, finishes, or gaps at back of surface, see Vary Easy® Program in Appendices.

For nonstandard formcoat paint colors, see Customer's Own Formcoat® Program in Appendices.

Specify secondary surface width as follows:

Surface Width—Side Wall Frame

72" wide—54" wide

96" wide—78" wide

Order supports separately:

- Secondary surface support (NT390.)
- Secondary surface end support (NT391.)

When bookcase is not used, order support leg (NT291.) separately. For additional information on surface and bookcase planning, see My Studio Environments™ Planning Guide.

Storage products and accessory products cannot attach to underside of surface.

For attached keyboard support, keyboard track adapter (Y7793.) must be specified with 1 of the following:

- Adjustable keyboard/mouse support (Y7710.)
- Fully adjustable keyboard/mouse support (Y7727.)

For freestanding keyboard support, order 1 of the following:

- Scooter® stand with input device (Y7708.)
- Scooter stand with wood top (Y7706.)

**Dimensions**

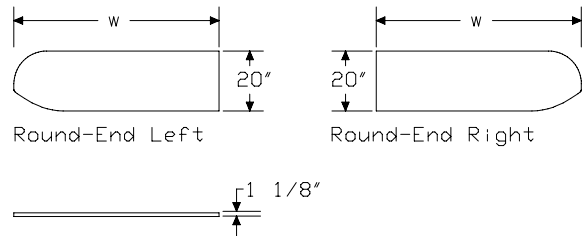

# Round-End Secondary Surface

continued

## Specification Information

Step 1.

**NT312.**

Step 2. Width

**72** 72" wide

**96** 96" wide

Step 3. Position

**L** round-end left

**R** round-end right

Step 4. Surface Material

**L** laminate

**W** veneer

**T** formcoat®

Prices for Steps 1-4.

	L	W	T
<b>NT312. 72 L</b>	\$224	591	493
<b>R</b>	\$224	591	493
<b>96 L</b>	\$254	634	560
<b>R</b>	\$254	634	560

Step 5. Top/Edge Finish

Solid-Color Laminate Top/Vinyl Edge

For laminate (L)

**8Q** folkstone grey  +\$0

**91** white  +\$0

**CL** cool grey neutral  +\$0

**LU** soft white  +\$0

**WL** sandstone  +\$0

**WN** warm grey neutral  +\$0

Zephyr Laminate Top/Vinyl Edge

For laminate (L)

**D1** canyon  +\$0

**DC** misted  +\$0

**DF** twilight  +\$0

**DQ** desert  +\$0

Wood Veneer

For veneer (W)

**2U** light brown walnut  +\$0

**3U** medium red cherry  +\$0

**6U** chocolate brown sapele  +\$0

**ED** aged cherry  +\$0

**EY** light anigre  +\$0

**UL** natural maple  +\$0

**UX** walnut on cherry  +\$0

Opaque Formcoat®

For formcoat® (T)

**8Q** folkstone grey  +\$0

**91** white  +\$0

**CL** cool grey neutral  +\$0

**LU** soft white  +\$0

**WL** sandstone  +\$0

**WN** warm grey neutral  +\$0

**X1** chalk white  +\$0

Fleck Formcoat®

For formcoat® (T)

**7F** natural maple fleck  +\$30

**7G** light anigre fleck  +\$30

**7H** aged cherry fleck  +\$30

# Secondary Surface Support

NT390.

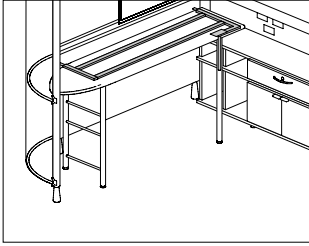

My Studio Environments™ Work Surfaces

## Product Information

### Description

This support attaches to the underside of a secondary surface, a side wall frame, and a closet or secondary surface end support. It has a post that fits into a bookcase leg, bookshelf leg, or support leg. The support places the surface height between 26½" and 31½". Finish is black. Attachment hardware is included.

### Notes

Specify width of support to match width of side wall frame.

When bookcase or bookshelf is not used, order support leg (NT291.) separately.

When closet is not used, order secondary surface end support (NT391.) separately.

Surface support extends 1" below surface; attaching screw head extends ¼" below support.

## Dimensions

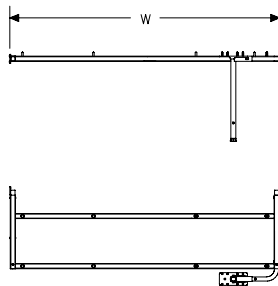

## Specification Information

### Step 1.

**NT390.**  A

### Step 2. Width

**54** 54" wide  A

**78** 78" wide  A

### Prices for Steps 1-2.

<b>NT390. 54</b>	\$210
<b>78</b>	\$229

# Support Leg

NT291.

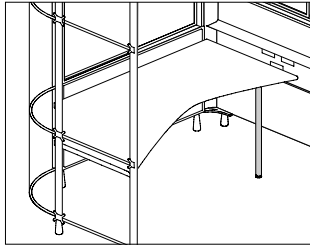

### Product Information

#### Description

This leg supports a primary or secondary surface in applications without a bookcase. The post of the primary or secondary surface support fits into the support leg. It is pin adjustable and has a height range of 26 1/2" to 31 1/2". The leg's leveling glide has 2" of height adjustment.

#### Dimensions

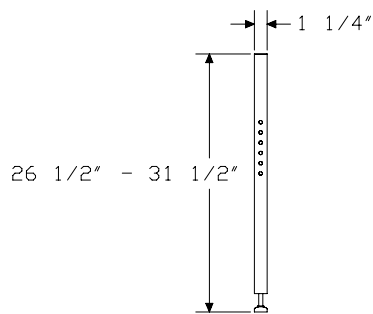

### Specification Information

#### Step 1.

**NT291.** [A] \$34

#### Step 2. Finish

<b>CN</b>	metallic champagne [A]	+\$0
<b>EH</b>	metallic bronze [A]	+\$0
<b>MS</b>	metallic silver [A]	+\$0

Secondary Surface End Support NT391.

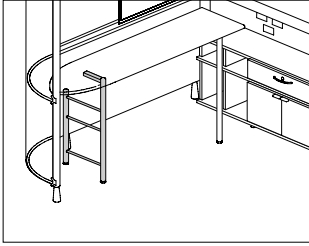

My Studio Environments™ Work Surfaces

**Product Information**

**Description**  
 This end support attaches to the underside of a secondary surface, a side wall frame, and a secondary surface support. It supports a secondary surface in applications without a closet. The support places the surface height at 28½" and has 2 leveling glides. Attachment hardware is included.

**Notes**

Order secondary surface support (NT390.) separately.

**Dimensions**

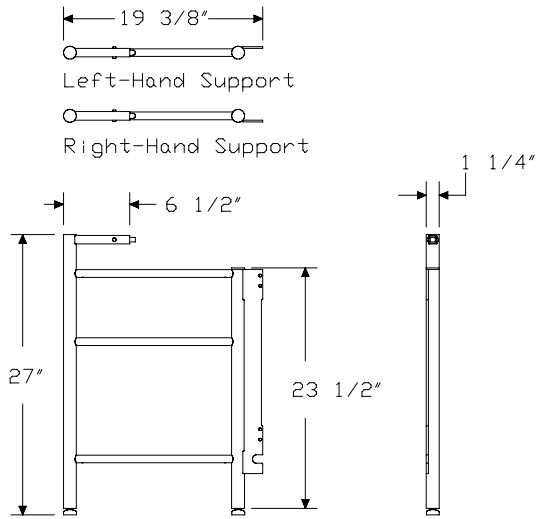

**Specification Information**

**Step 1.**

**NT391.**  A

**Step 2. Position**

- L** left-hand support  A
- R** right-hand support  A

**Prices for Steps 1-2.**

<b>NT391. L</b>	\$141
<b>R</b>	\$141

**Step 3. Finish**

<b>CN</b> metallic champagne <input type="checkbox"/> A	+ \$0
<b>EH</b> metallic bronze <input type="checkbox"/> A	+ \$0
<b>MS</b> metallic silver <input type="checkbox"/> A	+ \$0

Easel

NT430.

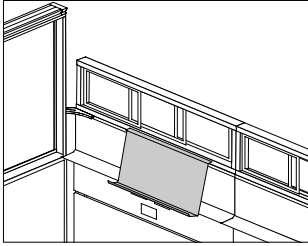

**Product Information**

**Description**

This 27"-wide painted easel hangs from a center wall frame's top cap or from a center wall transom's shutter track. It rests on the inside ledge to display documents.

**Notes**

Center walls can accept multiple easels:

Wall Width—Easels

6' wide—up to 2 easels

8' wide—up to 3 easels

10' wide—up to 4 easels

**Dimensions**

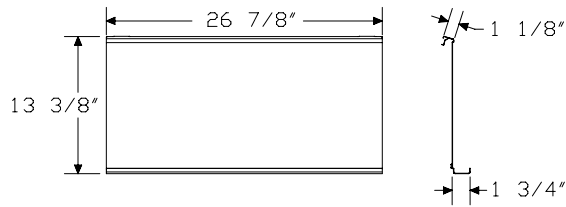

**Specification Information**

**Step 1.**

**NT430.** [A] \$77

**Step 2. Finish**

<b>91</b>	white [A]	+\$0
<b>CL</b>	cool grey neutral [A]	+\$0
<b>G1</b>	graphite [A]	+\$0
<b>WN</b>	warm grey neutral [A]	+\$0

# Message Board

NT431.

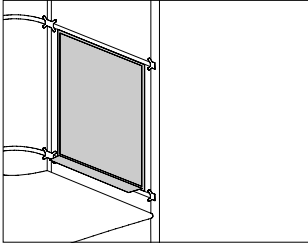

## Product Information

### Description

This 24"-wide message board attaches to the horizontal rails of a 28"-wide streetside straight frame. It has an anodized aluminum frame and is available with a marker board or tackable fabric surface.

### Notes

Message board cannot be used in 68"-high door application.

Marker board is tempered glass.

Order optional marker/eraser pouch (Y7230.) separately.

Fabric message board accepts Customer's Own Material (COM). For directional, 54"-wide fabrics, order minimum of 1 yard. For information on multiple quantities or nondirectional fabrics, contact COM Department. See Order Information in Appendices.

### Dimensions

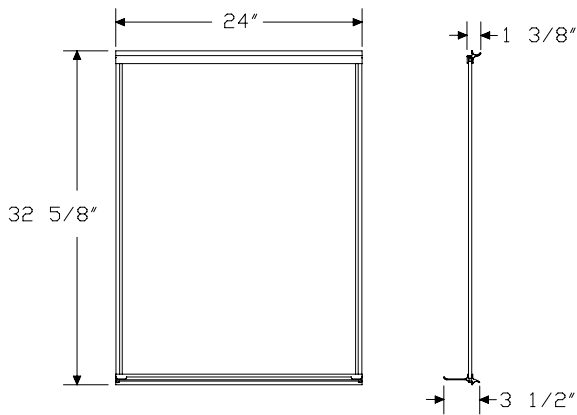

## Specification Information

### Step 1.

**NT431.**  A

### Step 2. Surface Material

**M** marker board  A

**T** tackable fabric  A

### Prices for Steps 1-2.

<b>NT431. M</b>	\$244
<b>T</b>	\$271

### Step 3. Fabric

*For tackable fabric (T)*

Price Category 1 + \$0

# Name Plate

NT434.

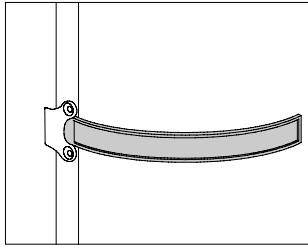

### Product Information

#### Description

This clear-plastic name plate attaches to a streetside curved frame. It provides name or office identification or displays messages on 1 side.

#### Notes

Perforated sheets for creating signage are available through Sales Source or visit the My Studio Environments page at [HermanMiller.com](http://HermanMiller.com) for a template.

#### Dimensions

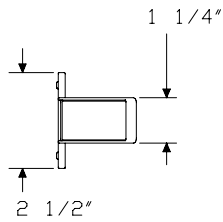
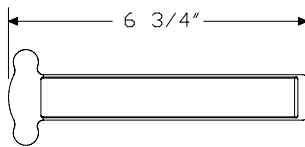

### Specification Information

#### Step 1.

NT434. A

\$27

# Bookcase

MJ420.

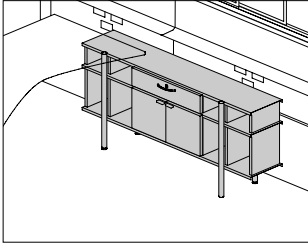

## Product Information

### Description

This freestanding storage unit is used within a workstation or used in a freestanding application. It stores books, binders, and other items and has a painted or veneer top. The bookcase can be specified with open shelves, with a box drawer and open shelf, or with a box drawer and a shelf with doors. The bookcase legs include 4 glides with 1 1/2" of leveling adjustment.

### Notes

Drawer and doors have ellipse pulls; pull finish is metallic silver (MS). Bookcases with a box drawer (MJ420.B) ship with 1 chrome lock; bookcases with a box drawer and doors (MJ420.C) ship with 2 chrome locks.

Order optional products separately:

- Bookcase back panel (MJ423.)
- Bookcase horizontal divider (MJ422.)

Bookcase legs support My Studio Environments™ primary and secondary surfaces.

Bookcase does not fit in a My Studio Environments 6' x 6' office.

For keyed-alike locks, order chrome lock plugs separately. See Keyed-Alike Information in Appendices.

My Studio Environments™ Storage

## Dimensions

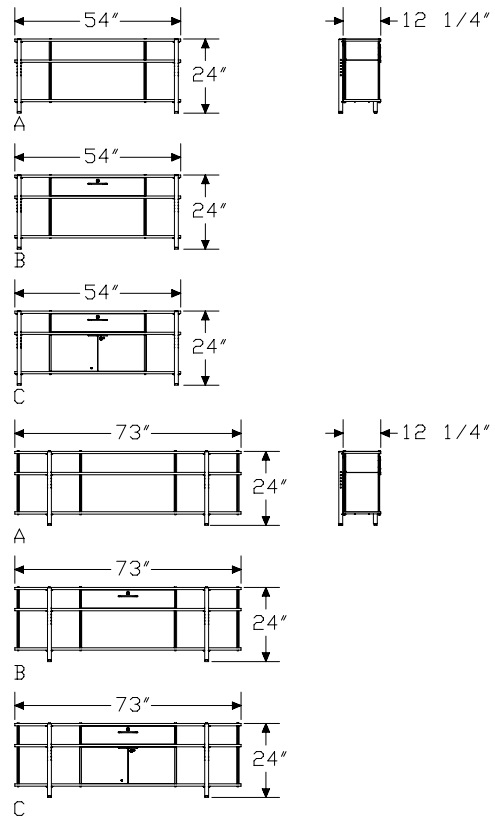

**Specification Information**

Step 1.  
**MJ420.**

Step 2. Width  
**54** 54" wide  
**73** 73" wide

Step 3. Configuration  
**A** open shelves  
**B** box drawer/open shelf  
**C** box drawer/shelf with doors

Step 4. Top Material  
**P** painted  
**W** veneer  A

Prices for Steps 1-4.		
	P	W
<b>MJ420. 54 A</b>	\$735	1058
<b>B</b>	\$919	1270
<b>C</b>	\$1066	1435
<b>73 A</b>	\$926	1478
<b>B</b>	\$1105	1518
<b>C</b>	\$1354	1786

Step 5. Top Finish

*For painted (P)*

<b>91</b>	white	+\$0
<b>CN</b>	metallic champagne	+\$0
<b>EH</b>	metallic bronze	+\$0
<b>G1</b>	graphite	+\$0
<b>MS</b>	metallic silver	+\$0

Wood Veneer

*For veneer (W)*

<b>2U</b>	light brown walnut <input type="checkbox"/> A	+\$28
<b>3U</b>	medium red cherry <input type="checkbox"/> A	+\$28
<b>6U</b>	chocolate brown sapele <input type="checkbox"/> A	+\$28
<b>ED</b>	aged cherry <input type="checkbox"/> A	+\$28
<b>EY</b>	light anigre <input type="checkbox"/> A	+\$28
<b>UL</b>	natural maple <input type="checkbox"/> A	+\$28
<b>UX</b>	walnut on cherry <input type="checkbox"/> A	+\$28

Step 6. Shelf Finish

<b>91</b>	white	+\$0
<b>CN</b>	metallic champagne	+\$0
<b>EH</b>	metallic bronze	+\$0
<b>G1</b>	graphite	+\$0
<b>MS</b>	metallic silver	+\$0

Step 7. Vertical Surface Finish

<b>91</b>	white	+\$0
<b>CL</b>	cool grey neutral	+\$0
<b>G1</b>	graphite	+\$0
<b>WN</b>	warm grey neutral	+\$0

Step 8.

Drawer Front Finish: Sand Texture Paint

*For box drawer/open shelf (B)*

<b>7L</b>	dune	+\$0
<b>7M</b>	chai	+\$0
<b>7N</b>	grass	+\$0
<b>7U</b>	blue ridge	+\$0
<b>7V</b>	loden	+\$0
<b>7W</b>	napa	+\$0
<b>7Y</b>	sedona	+\$0
<b>7Z</b>	mink	+\$0
<b>8T</b>	gull	+\$0
<b>8Y</b>	moonbeam	+\$0
<b>B4</b>	blue medium	+\$0
<b>ZK</b>	cappuccino	+\$0

Drawer Front Finish: Bright Sand Texture Paint

*For box drawer/open shelf (B)*

<b>91</b>	white	+\$0
<b>CL</b>	cool grey neutral	+\$0
<b>G1</b>	graphite	+\$0
<b>WN</b>	warm grey neutral	+\$0

---

Drawer/Door Front Finish: Sand Texture Paint  
*For box drawer/shelf with doors (C)*

---

<b>7L</b>	dune	+\$0
<b>7M</b>	chai	+\$0
<b>7N</b>	grass	+\$0
<b>7U</b>	blue ridge	+\$0
<b>7V</b>	loden	+\$0
<b>7W</b>	napa	+\$0
<b>7Y</b>	sedona	+\$0
<b>7Z</b>	mink	+\$0
<b>8T</b>	gull	+\$0
<b>8Y</b>	moonbeam	+\$0
<b>B4</b>	blue medium	+\$0
<b>ZK</b>	cappuccino	+\$0

---

Drawer/Door Front Finish: Bright Sand Texture Paint  
*For box drawer/shelf with doors (C)*

---

<b>91</b>	white	+\$0
<b>CL</b>	cool grey neutral	+\$0
<b>G1</b>	graphite	+\$0
<b>WN</b>	warm grey neutral	+\$0

---

Step 9. Leg Finish

<b>CN</b>	metallic champagne	+\$0
<b>EH</b>	metallic bronze	+\$0
<b>MS</b>	metallic silver	+\$0

---

Step 10. Lock Option  
*For box drawer/open shelf (B) or box drawer/shelf with doors (C)*

<b>KA</b>	keyed alike	+\$0
<b>KC</b>	keyed differently, chrome	+\$0

# Bookcase Back Panel

MJ423.

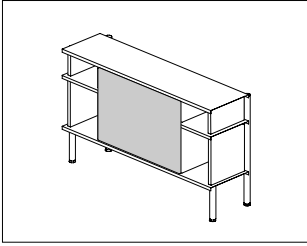

### Product Information

#### Description

This back panel provides security for a bookcase used in a freestanding application. It is field installed.

#### Notes

Back panel can be used with 54"- or 73"-wide bookcase.  
 When bookcase is used as a support element for My Studio Environments™ offices, back panel is not necessary.

#### Dimensions

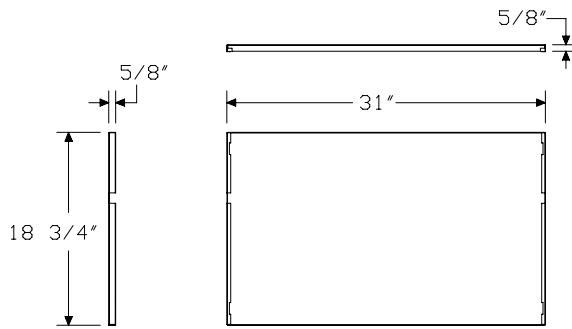

### Specification Information

#### Step 1.

**MJ423.** \$80

#### Step 2. Surface Finish

<b>91</b>	white	+\$0
<b>EH</b>	metallic bronze	+\$0
<b>G1</b>	graphite	+\$0
<b>MS</b>	metallic silver	+\$0

# Bookshelf

MJ421.

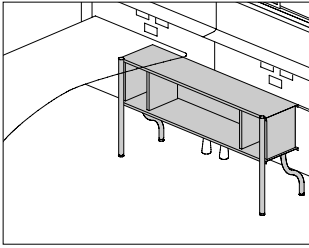

## Product Information

### Description

This 49"-wide freestanding storage unit is used within a workstation or in a freestanding application. It stores books, binders, and other items and has a painted or veneer top. The bookshelf legs include 4 glides with 1½" of leveling adjustment.

### Notes

Bookshelf fits in a My Studio Environments™ 6'×6' office.  
1 bookshelf leg supports a My Studio Environments primary surface.

### Dimensions

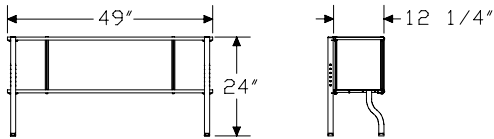

My Studio Environments™ Storage

## Specification Information

### Step 1.

**MJ421.**

### Step 2. Top Material

**P** painted  
**W** veneer

### Prices for Steps 1-2.

<b>MJ421. P</b>	\$630
<b>W</b>	\$934

### Step 3. Top Finish

#### For painted (P)

<b>91</b>	white	+\$0
<b>CN</b>	metallic champagne	+\$0
<b>EH</b>	metallic bronze	+\$0
<b>G1</b>	graphite	+\$0
<b>MS</b>	metallic silver	+\$0

#### Wood Veneer

#### For veneer (W)

<b>2U</b>	light brown walnut <input type="checkbox"/>	+\$28
<b>3U</b>	medium red cherry <input type="checkbox"/>	+\$28
<b>6U</b>	chocolate brown sapele <input type="checkbox"/>	+\$28
<b>ED</b>	aged cherry <input type="checkbox"/>	+\$28
<b>EY</b>	light anigre <input type="checkbox"/>	+\$28
<b>UL</b>	natural maple <input type="checkbox"/>	+\$28
<b>UX</b>	walnut on cherry <input type="checkbox"/>	+\$28

### Step 4. Shelf Finish

<b>91</b>	white	+\$0
<b>CN</b>	metallic champagne	+\$0
<b>EH</b>	metallic bronze	+\$0
<b>G1</b>	graphite	+\$0
<b>MS</b>	metallic silver	+\$0

### Step 5. Vertical Surface Finish

<b>91</b>	white	+\$0
<b>CL</b>	cool grey neutral	+\$0
<b>G1</b>	graphite	+\$0
<b>WN</b>	warm grey neutral	+\$0

## Bookshelf *continued*

---

### Step 6. Leg Finish

<b>CN</b>	metallic champagne	+\$0
<b>EH</b>	metallic bronze	+\$0
<b>MS</b>	metallic silver	+\$0

Bookcase Horizontal Divider

MJ422.

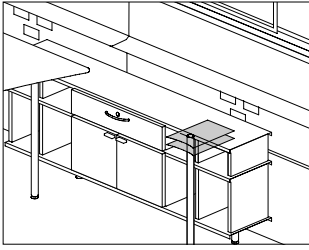

**Product Information**

**Description**  
 These dividers fit into the small upper compartments of a bookcase to horizontally divide papers. Package contains 2.

**Notes**  
 54"-wide bookcase has 2 upper compartments; 73"-wide bookcase has 4 upper compartments (only the 2 middle compartments accept dividers). Each compartment accepts 2 dividers.

**Dimensions**

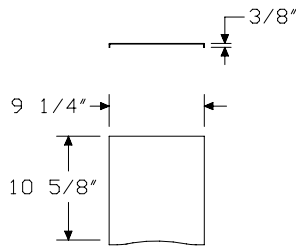

**Specification Information**

**Step 1.**  
**MJ422.** \$33

**Step 2. Finish**

<b>91</b>	white	+\$0
<b>CN</b>	metallic champagne	+\$0
<b>EH</b>	metallic bronze	+\$0
<b>G1</b>	graphite	+\$0
<b>MS</b>	metallic silver	+\$0

# Rolling Tool Rail

NT412.

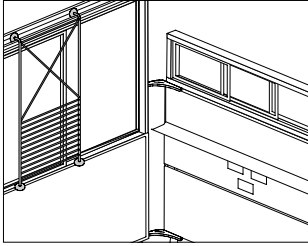

### Product Information

#### Description

This 35"-high metal tool rail hangs on a 68"-high side wall frame. It holds work tools and can roll from side-to-side. A maximum of 2 tool rails can hang from a 54"-wide side wall; a maximum of 3 tool rails can hang from a 78"-wide side wall.

#### Notes

For accessory product applications, the following Compatibility Chart is available electronically for viewing and printing in Kiosk and HermanMiller.com: Work Organizer Compatibility Chart.

#### Dimensions

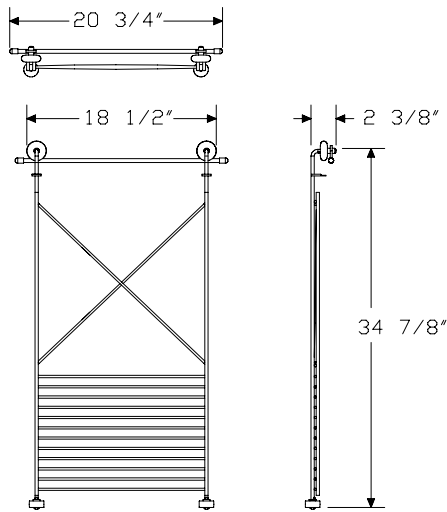

### Specification Information

#### Step 1.

**NT412.35** A \$208

#### Step 2. Finish

<b>CN</b>	metallic champagne <span style="border: 1px solid black; padding: 0 2px;">A</span>	+\$0
<b>EH</b>	metallic bronze <span style="border: 1px solid black; padding: 0 2px;">A</span>	+\$0
<b>MS</b>	metallic silver <span style="border: 1px solid black; padding: 0 2px;">A</span>	+\$0

Tool Rail

NT413.

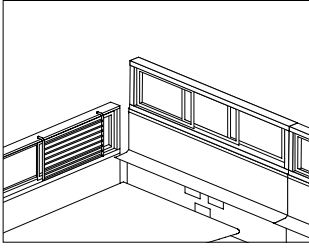

**Product Information**

Description

This 13"-high metal tool rail hangs on a 46"-high side wall frame and holds work tools. A maximum of 2 tool rails can hang from a 54"-wide side wall; a maximum of 3 tool rails can hang from a 78"-wide side wall.

Notes

For accessory product applications, the following Compatibility Chart is available electronically for viewing and printing in Kiosk and HermanMiller.com: Work Organizer Compatibility Chart.

Dimensions

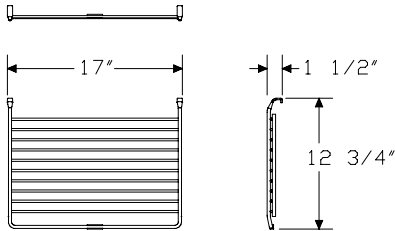

**Specification Information**

Step 1.

**NT413.13** [A] \$177

Step 2. Finish

<b>CN</b>	metallic champagne [A]	+\$0
<b>EH</b>	metallic bronze [A]	+\$0
<b>MS</b>	metallic silver [A]	+\$0

# Closet

NT425.

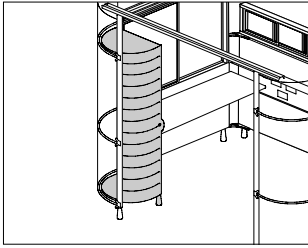

### Product Information

#### Description

This 68"-high, lockable storage unit attaches to a streetside curved frame and a secondary surface support. It provides secured storage of personal items. The closet includes a plastic door with a chrome lock and an adjustable glide. Attachment hardware is included. Shipped knocked down.

#### Notes

Closet attaches to 68"- or 81"-high streetside curved frames (NT130.68N or NT130.81N).

Closet accepts up to 4 additional shelves; order closet shelves (NT426.) separately.

Order optional coat hook (NT433.) separately.

For keyed-alike locks, order chrome lock plugs separately. See Keyed-Alike Information in Appendices.

#### Dimensions

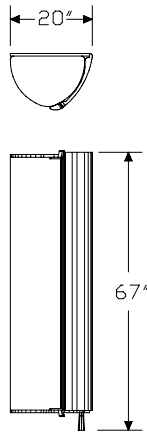

### Specification Information

#### Step 1.

**NT425.68**  \$587

#### Step 2. Door Finish

<b>91</b>	white <input type="checkbox"/>	+\$0
<b>CL</b>	cool grey neutral <input type="checkbox"/>	+\$0
<b>G1</b>	graphite <input type="checkbox"/>	+\$0
<b>WN</b>	warm grey neutral <input type="checkbox"/>	+\$0

#### Step 3. Cabinet/Shelf Finish

<b>91</b>	white <input type="checkbox"/>	+\$0
<b>CN</b>	metallic champagne <input type="checkbox"/>	+\$0
<b>EH</b>	metallic bronze <input type="checkbox"/>	+\$0
<b>G1</b>	graphite <input type="checkbox"/>	+\$0
<b>MS</b>	metallic silver <input type="checkbox"/>	+\$0

#### Step 4. Lock Option

<b>KA</b>	keyed alike <input type="checkbox"/>	+\$0
<b>KC</b>	keyed differently, chrome <input type="checkbox"/>	+\$0

My Studio Environments™ Storage

Closet Shelf

NT426.

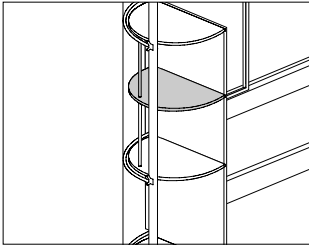

**Product Information**

Description

This metal shelf can be added to a closet for additional shelf space. A maximum of 4 shelves can be added. Attachment hardware is included.

Dimensions

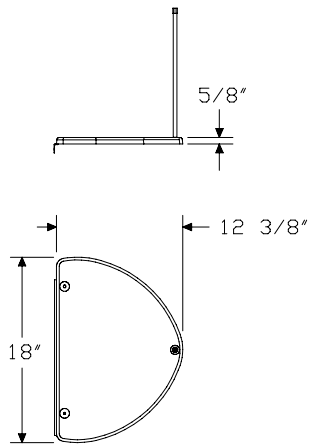

**Specification Information**

Step 1.

**NT426.** [A] \$62

Step 2. Finish

<b>91</b>	white [A]	+\$0
<b>CN</b>	metallic champagne [A]	+\$0
<b>EH</b>	metallic bronze [A]	+\$0
<b>G1</b>	graphite [A]	+\$0
<b>MS</b>	metallic silver [A]	+\$0

# Coat Hook

NT433.

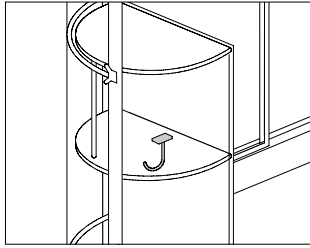

### Product Information

#### Description

This coat hook attaches to the underside of a closet shelf or to a streetside curved frame to hang coats, hats, and umbrellas. Finish is bright zinc.

#### Dimensions

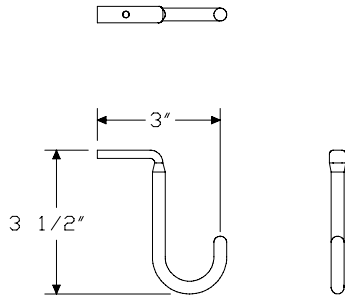

### Specification Information

#### Step 1.

**NT433.**  A

#### Step 2. Quantity

**1** 1 coat hook  A

**2** 2 coat hooks  A

#### Prices for Steps 1-2.

<b>NT433. 1</b>	\$25
<b>2</b>	\$48

## Ellipse-Pull Freestanding Lateral File

2J-30  
2J-36  
2J-42

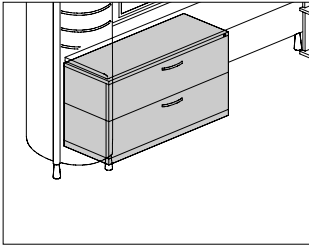

### Product Information

#### Description

This lateral file holds letter-, legal-, and A4-size hanging files. It has ellipse pulls and smooth steel. The file has no top or a metal, cushion, laminate, planter, or veneer top. A positive interlock system permits only 1 drawer to open at a time. 1 lock controls all drawers. The drawers can be specified with 3 dividers or with front-to-back or side-to-side filing rails for hanging files. 5 base heights are available; all bases include adjustable glides.

Actual lateral file widths are 29<sup>7</sup>/<sub>8</sub>" , 35<sup>7</sup>/<sub>8</sub>" , or 41<sup>7</sup>/<sub>8</sub>" ; actual depths are 17<sup>7</sup>/<sub>8</sub>" or 19<sup>7</sup>/<sub>8</sub>" .

Zephyr laminate edge colors are predetermined for top options T4 and T5:

Top Color—Edge Color

Canyon (D1)—Warm Grey Neutral (WN)

Misted (DC)—Cool Grey Neutral (CL)

Twilight (DF)—Graphite Satin (G2)

Desert (DQ)—Warm Grey Neutral (WN)

#### Notes

For 2- or 3-high files that are not ganged or anchored, counterweights (option CB) are required. For 4- or 5-high files that are not ganged or anchored, counterweights are recommended.

Dimensional illustrations do not include all possible configurations.

To convert filing direction, order 1 of the following products separately:

- Front-to-back rail (9P002)
- Side-to-side rail (9R130)

Order optional file drawer organizer (LG901) separately.

For work surface on top of 1 or more lateral files, order file top (TPL or TPV) separately.

No lock option (NL) can only be specified on files with no top (NT), dome tops (D1, D3, H1, H2, H5, or H6), planter top (T7), or laminate tops (T5 or TL). The (NL) option cannot be specified for configurations 4W and 4Z; these configurations always have a lock.

For configurations 4W and 4Z, a 1" filler top is included between the overhead storage and the drawers.

For cushion tops TC1 and TC2, a 1" metal top is included.

Cushion top accepts Customer's Own Material (COM). Yardage is estimated for nondirectional, 54"-wide fabrics. When ordering more than 1 cushion, round up total yardage requirement to next whole yard of fabric.

Width—Yardage

30"—1.05

36"—1.22

42"—1.40

For information on multiple quantities or directional fabrics, contact COM Department. See Order Information in Appendices.

For keyed-alike locks, order lock plugs separately. See Keyed-Alike Information in Appendices.

# Ellipse-Pull Freestanding Lateral File *continued*

## Dimensions

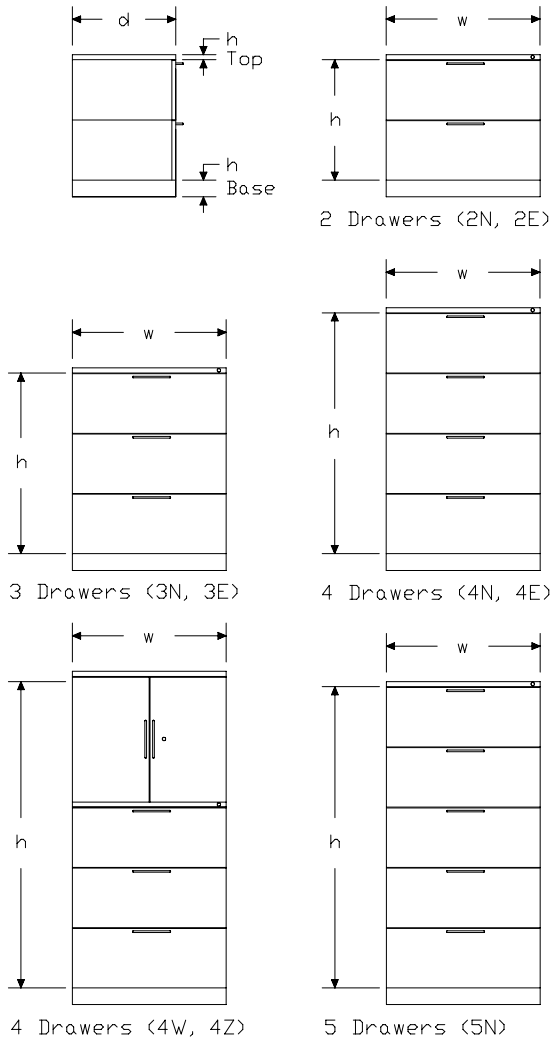

h	N	E	W	Z
2	23 1/2	26 1/4	-	-
3	35 1/4	39 3/8	-	-
4	47	52 1/2	62 1/2	66 5/8
5	58 3/4	-	-	-

All dimensions are in inches.

## Specification Information

Step 1.

2J-  A

Step 2. Width

30 30" wide  A

36 36" wide  A

42 42" wide  A

Step 3. Depth

18- 18" deep  A

20- 20" deep  A

Step 4. Configuration

2N 2 11 3/4"-high drawers  A

3N 3 11 3/4"-high drawers  A

4N 4 11 3/4"-high drawers  A

4W 1 26 1/4"-high overhead storage, 3 11 3/4"-high drawers  A

5N 5 11 3/4"-high drawers  A

2E 2 13 1/8"-high drawers  A

3E 3 13 1/8"-high drawers  A

4E 4 13 1/8"-high drawers  A

4Z 1 26 1/4"-high overhead storage, 3 13 1/8"-high drawers  A

Prices for Steps 1-4.

		2N	3N	4N	4W	5N	2E	3E		
2J-30	18-	\$775	1082	1388	1714	1693	775	1082		
	20-	\$775	1082	1388	1714	1693	775	1082		
2J-36	18-	\$862	1195	1530	1912	1863	862	1195		
	20-	\$862	1195	1530	1912	1863	862	1195		
2J-42	18-	\$976	1352	1729	2163	2108	976	1352		
	20-	\$976	1352	1729	2163	2108	976	1352		
									4E	4Z
2J-30	18-						\$1388	1714		
	20-						\$1388	1714		
2J-36	18-						\$1530	1912		
	20-						\$1530	1912		
2J-42	18-						\$1729	2163		
	20-						\$1729	2163		

# Ellipse-Pull Freestanding Lateral

File *continued*

## Step 5. Paint/Steel Type

<b>SS</b>	smooth paint on smooth steel <input type="checkbox"/>	+\$0
<b>TS</b>	smooth paint on textured steel <input type="checkbox"/>	+\$0
<b>XS</b>	textured paint on smooth steel <input type="checkbox"/>	+\$0

## Step 6. Case Finish

*For smooth paint on smooth steel (SS) or smooth paint on textured steel (TS)*

Nonmetallic Paint	+\$0
Metallic Paint	+\$65

## Sand Texture Paint

*For textured paint on smooth steel (XS)*

<b>7L</b>	dune <input type="checkbox"/>	+\$0
<b>7M</b>	chai <input type="checkbox"/>	+\$0
<b>7N</b>	grass <input type="checkbox"/>	+\$0
<b>7U</b>	blue ridge <input type="checkbox"/>	+\$0
<b>7V</b>	loden <input type="checkbox"/>	+\$0
<b>7W</b>	napa <input type="checkbox"/>	+\$0
<b>7Y</b>	sedona <input type="checkbox"/>	+\$0
<b>7Z</b>	mink <input type="checkbox"/>	+\$0
<b>8T</b>	gull <input type="checkbox"/>	+\$0
<b>8Y</b>	moonbeam <input type="checkbox"/>	+\$0
<b>B4</b>	blue medium <input type="checkbox"/>	+\$0
<b>ZK</b>	cappuccino <input type="checkbox"/>	+\$0

## Bright Sand Texture Paint

*For textured paint on smooth steel (XS)*

<b>91</b>	white <input type="checkbox"/>	+\$0
<b>CL</b>	cool grey neutral <input type="checkbox"/>	+\$0
<b>G1</b>	graphite <input type="checkbox"/>	+\$0
<b>WN</b>	warm grey neutral <input type="checkbox"/>	+\$0

## Step 7. Front Finish

*For smooth paint on smooth steel (SS) or smooth paint on textured steel (TS)*

Nonmetallic Paint	+\$0
Metallic Paint	+\$0

## Sand Texture Paint

*For textured paint on smooth steel (XS)*

<b>7L</b>	dune <input type="checkbox"/>	+\$0
<b>7M</b>	chai <input type="checkbox"/>	+\$0
<b>7N</b>	grass <input type="checkbox"/>	+\$0
<b>7U</b>	blue ridge <input type="checkbox"/>	+\$0
<b>7V</b>	loden <input type="checkbox"/>	+\$0
<b>7W</b>	napa <input type="checkbox"/>	+\$0
<b>7Y</b>	sedona <input type="checkbox"/>	+\$0
<b>7Z</b>	mink <input type="checkbox"/>	+\$0
<b>8T</b>	gull <input type="checkbox"/>	+\$0
<b>8Y</b>	moonbeam <input type="checkbox"/>	+\$0
<b>B4</b>	blue medium <input type="checkbox"/>	+\$0
<b>ZK</b>	cappuccino <input type="checkbox"/>	+\$0

## Bright Sand Texture Paint

*For textured paint on smooth steel (XS)*

<b>91</b>	white <input type="checkbox"/>	+\$0
<b>CL</b>	cool grey neutral <input type="checkbox"/>	+\$0
<b>G1</b>	graphite <input type="checkbox"/>	+\$0
<b>WN</b>	warm grey neutral <input type="checkbox"/>	+\$0

## Step 8. Top

<b>NT</b>	no top <input type="checkbox"/>	+\$0
<b>T1</b>	1"-high painted metal top with squared edge <input type="checkbox"/>	+\$0
<b>T2</b>	1 1/4"-high painted metal top with squared edge <input type="checkbox"/>	+\$0
<b>T3</b>	1 1/4"-high painted metal top with radius edge <input type="checkbox"/>	+\$55
<b>TL</b>	1 1/4"-high laminate top with vinyl edge <input type="checkbox"/>	+\$63
<b>T4</b>	1 1/4"-high laminate top with squared edge <input type="checkbox"/>	+\$120
<b>TR</b>	1 1/4"-high recut veneer top <input type="checkbox"/>	+\$132
<b>J3</b>	1 1/4"-high cathedral recut veneer top <input type="checkbox"/>	+\$135
<b>TF</b>	1 1/4"-high wood veneer top <input type="checkbox"/>	+\$137
<b>T7</b>	6 1/2"-high planter top <input type="checkbox"/>	+\$177
<b>T5</b>	1 1/4"-high laminate top with radius edge <input type="checkbox"/>	+\$242
<b>D1</b>	6 1/2"-high full dome, side-to-side <input type="checkbox"/>	+\$242
<b>D3</b>	4 1/2"-high full dome, side-to-side <input type="checkbox"/>	+\$242
<b>H1</b>	6 1/2"-high half dome, sloping left <input type="checkbox"/>	+\$242
<b>H2</b>	6 1/2"-high half dome, sloping right <input type="checkbox"/>	+\$242
<b>H5</b>	4 1/2"-high half dome, sloping left <input type="checkbox"/>	+\$242
<b>H6</b>	4 1/2"-high half dome, sloping right <input type="checkbox"/>	+\$242
<b>TV1</b>	1 1/8"-high wood veneer top and wood composite edge with oversail front <input type="checkbox"/>	+\$284
<b>TC1</b>	1" cushion top <input type="checkbox"/>	+\$350
<b>TC2</b>	2" cushion top <input type="checkbox"/>	+\$350

# Ellipse-Pull Freestanding Lateral File *continued*

## Step 9. Lock

For 1 26<sup>1</sup>/<sub>4</sub>"-high overhead storage, 3 11<sup>3</sup>/<sub>4</sub>"-high drawers (4W) or 1 26<sup>1</sup>/<sub>4</sub>"-high overhead storage, 3 13<sup>1</sup>/<sub>8</sub>"-high drawers (4Z)

<b>KA</b>	keyed alike <input type="checkbox"/>	+\$0
<b>KC</b>	keyed differently, chrome <input type="checkbox"/>	+\$0
<b>KD</b>	keyed differently, black <input type="checkbox"/>	+\$0

For configurations 2N, 2E, 3N, 3E, 4N, 4E, 5N with a top choice of no top (NT), laminate top (TL, T5), dome top (D1, D3, H1, H2, H5, H6), planter top (T7), or 1<sup>1</sup>/<sub>8</sub>"-high wood veneer top and wood composite edge with oversail front (TV1)

<b>NL</b>	no lock <input type="checkbox"/>	-\$26
-----------	----------------------------------	-------

For configurations 2N, 2E, 3N, 3E, 4N, 4E, 5N with a top choice of painted metal top (T1, T2, T3), laminate top (T4), veneer top (J3, TF, TR), or cushion top (TC1, TC2)

<b>KA</b>	keyed alike <input type="checkbox"/>	+\$0
<b>KC</b>	keyed differently, chrome <input type="checkbox"/>	+\$0
<b>KD</b>	keyed differently, black <input type="checkbox"/>	+\$0

## Step 10.

### Top Finish: Solid-Color Laminate

For 1<sup>1</sup>/<sub>4</sub>"-high laminate top with vinyl edge (TL)

<b>8Q</b>	folkstone grey <input type="checkbox"/>	+\$0
<b>91</b>	white <input type="checkbox"/>	+\$0
<b>CL</b>	cool grey neutral <input type="checkbox"/>	+\$0
<b>HF</b>	inner tone light <input type="checkbox"/>	+\$0
<b>HT</b>	inner tone <input type="checkbox"/>	+\$0
<b>LT</b>	light tone <input type="checkbox"/>	+\$0
<b>LU</b>	soft white <input type="checkbox"/>	+\$0
<b>WL</b>	sandstone <input type="checkbox"/>	+\$0
<b>WN</b>	warm grey neutral <input type="checkbox"/>	+\$0

### Top Finish: Fiber Laminate

For 1<sup>1</sup>/<sub>4</sub>"-high laminate top with vinyl edge (TL)

<b>1X</b>	vanilla <input type="checkbox"/>	+\$0
<b>2X</b>	wheat <input type="checkbox"/>	+\$0
<b>3X</b>	celery <input type="checkbox"/>	+\$0
<b>4X</b>	coriander <input type="checkbox"/>	+\$0
<b>5X</b>	chamomile <input type="checkbox"/>	+\$0
<b>6X</b>	cinnamon <input type="checkbox"/>	+\$0
<b>7X</b>	cardamom <input type="checkbox"/>	+\$0
<b>8X</b>	kale <input type="checkbox"/>	+\$0

### Top Finish: Frosted Laminate

For 1<sup>1</sup>/<sub>4</sub>"-high laminate top with vinyl edge (TL)

<b>J4</b>	frosted light grey <input type="checkbox"/>	+\$0
<b>J5</b>	frosted inner tone light <input type="checkbox"/>	+\$0
<b>J6</b>	frosted slate grey <input type="checkbox"/>	+\$0
<b>J7</b>	frosted medium tone <input type="checkbox"/>	+\$0
<b>J8</b>	frosted black <input type="checkbox"/>	+\$0

### Top Finish: Wood-Grain Laminate

For 1<sup>1</sup>/<sub>4</sub>"-high laminate top with vinyl edge (TL)

<b>LA</b>	light ash <input type="checkbox"/>	+\$0
<b>LM</b>	mahogany <input type="checkbox"/>	+\$0

### Top Finish: Zephyr Laminate

For 1<sup>1</sup>/<sub>4</sub>"-high laminate top with vinyl edge (TL)

<b>D1</b>	canyon <input type="checkbox"/>	+\$0
<b>DC</b>	misted <input type="checkbox"/>	+\$0
<b>DF</b>	twilight <input type="checkbox"/>	+\$0
<b>DQ</b>	desert <input type="checkbox"/>	+\$0

### Top/Edge Finish: Solid-Color Laminate

For 1<sup>1</sup>/<sub>4</sub>"-high laminate top with squared edge (T4) or 1<sup>1</sup>/<sub>4</sub>"-high laminate top with radius edge (T5)

<b>8Q</b>	folkstone grey <input type="checkbox"/>	+\$0
<b>91</b>	white <input type="checkbox"/>	+\$0
<b>CL</b>	cool grey neutral <input type="checkbox"/>	+\$0
<b>HF</b>	inner tone light <input type="checkbox"/>	+\$0
<b>HT</b>	inner tone <input type="checkbox"/>	+\$0
<b>LT</b>	light tone <input type="checkbox"/>	+\$0
<b>LU</b>	soft white <input type="checkbox"/>	+\$0
<b>WL</b>	sandstone <input type="checkbox"/>	+\$0
<b>WN</b>	warm grey neutral <input type="checkbox"/>	+\$0

### Top/Edge Finish: Fiber Laminate

For 1<sup>1</sup>/<sub>4</sub>"-high laminate top with squared edge (T4) or 1<sup>1</sup>/<sub>4</sub>"-high laminate top with radius edge (T5)

<b>1X</b>	vanilla <input type="checkbox"/>	+\$0
<b>2X</b>	wheat <input type="checkbox"/>	+\$0
<b>3X</b>	celery <input type="checkbox"/>	+\$0
<b>4X</b>	coriander <input type="checkbox"/>	+\$0
<b>5X</b>	chamomile <input type="checkbox"/>	+\$0
<b>6X</b>	cinnamon <input type="checkbox"/>	+\$0
<b>7X</b>	cardamom <input type="checkbox"/>	+\$0
<b>8X</b>	kale <input type="checkbox"/>	+\$0

# Ellipse-Pull Freestanding Lateral

File *continued*

**Top/Edge Finish: Frosted Laminate**

*For 1 1/4"-high laminate top with squared edge (T4) or 1 1/4"-high laminate top with radius edge (T5)*

<b>J4</b>	frosted light grey <input type="checkbox"/>	+\$0
<b>J5</b>	frosted inner tone light <input type="checkbox"/>	+\$0
<b>J6</b>	frosted slate grey <input type="checkbox"/>	+\$0
<b>J7</b>	frosted medium tone <input type="checkbox"/>	+\$0
<b>J8</b>	frosted black <input type="checkbox"/>	+\$0

**Top/Edge Finish: Wood-Grain Laminate**

*For 1 1/4"-high laminate top with squared edge (T4) or 1 1/4"-high laminate top with radius edge (T5)*

<b>LA</b>	light ash <input type="checkbox"/>	+\$0
<b>LM</b>	mahogany <input type="checkbox"/>	+\$0

**Top/Edge Finish: Zephyr Laminate**

*For 1 1/4"-high laminate top with squared edge (T4) or 1 1/4"-high laminate top with radius edge (T5)*

<b>D1</b>	canyon <input type="checkbox"/>	+\$0
<b>DC</b>	misted <input type="checkbox"/>	+\$0
<b>DF</b>	twilight <input type="checkbox"/>	+\$0
<b>DQ</b>	desert <input type="checkbox"/>	+\$0

**Veneer Top Finish: Recut Veneer**

*For 1 1/4"-high recut veneer top (TR)*

<b>RA</b>	light ash <input type="checkbox"/>	+\$0
<b>RK</b>	mahogany dark <input type="checkbox"/>	+\$0
<b>RM</b>	mahogany <input type="checkbox"/>	+\$0

**Veneer Top Finish: Recut Veneer**

*For 1 1/4"-high cathedral recut veneer top (J3)*

<b>DU</b>	cathedral recut natural maple <input type="checkbox"/>	+\$0
<b>HU</b>	cathedral recut light anigre <input type="checkbox"/>	+\$0
<b>JU</b>	cathedral recut aged cherry <input type="checkbox"/>	+\$0
<b>VU</b>	cathedral recut light brown walnut <input type="checkbox"/>	+\$0
<b>WU</b>	cathedral recut walnut on cherry <input type="checkbox"/>	+\$0
<b>XU</b>	cathedral recut medium red cherry <input type="checkbox"/>	+\$0
<b>ZU</b>	cathedral recut chocolate brown sapele <input type="checkbox"/>	+\$0

**Veneer Top Finish: Wood Veneer**

*For 1 1/4"-high wood veneer top (TF)*

<b>V3</b>	cherry <input type="checkbox"/>	+\$21
<b>Z3</b>	warm red cherry <input type="checkbox"/>	+\$21
<b>Z5</b>	maple <input type="checkbox"/>	+\$21
<b>2U</b>	light brown walnut <input type="checkbox"/>	+\$28
<b>3U</b>	medium red cherry <input type="checkbox"/>	+\$28
<b>6U</b>	chocolate brown sapele <input type="checkbox"/>	+\$28
<b>ED</b>	aged cherry <input type="checkbox"/>	+\$28
<b>EG</b>	medium brown walnut <input type="checkbox"/>	+\$28
<b>EK</b>	medium red walnut <input type="checkbox"/>	+\$28
<b>EY</b>	light anigre <input type="checkbox"/>	+\$28
<b>UL</b>	natural maple <input type="checkbox"/>	+\$28
<b>UQ</b>	light cherry <input type="checkbox"/>	+\$28
<b>UV</b>	red cherry <input type="checkbox"/>	+\$28
<b>UX</b>	walnut on cherry <input type="checkbox"/>	+\$28

**Veneer Top Finish: Wood Veneer**

*For 1 1/8"-high wood veneer top and wood composite edge with oversail front (TV1)*

<b>ED</b>	aged cherry <input type="checkbox"/>	+\$28
<b>EG</b>	medium brown walnut <input type="checkbox"/>	+\$28
<b>EK</b>	medium red walnut <input type="checkbox"/>	+\$28
<b>EY</b>	light anigre <input type="checkbox"/>	+\$28
<b>UL</b>	natural maple <input type="checkbox"/>	+\$28
<b>UQ</b>	light cherry <input type="checkbox"/>	+\$28
<b>UV</b>	red cherry <input type="checkbox"/>	+\$28
<b>UX</b>	walnut on cherry <input type="checkbox"/>	+\$28

**Step 11. Edge Finish**

*For 1 1/4"-high laminate top with vinyl edge (TL)*

<b>8Q</b>	folkstone grey <input type="checkbox"/>	+\$0
<b>91</b>	white <input type="checkbox"/>	+\$0
<b>BU</b>	black umber <input type="checkbox"/>	+\$0
<b>CL</b>	cool grey neutral <input type="checkbox"/>	+\$0
<b>CM</b>	cinnamon <input type="checkbox"/>	+\$0
<b>CO</b>	chamomile <input type="checkbox"/>	+\$0
<b>G2</b>	graphite satin <input type="checkbox"/>	+\$0
<b>HF</b>	inner tone light <input type="checkbox"/>	+\$0
<b>HT</b>	inner tone <input type="checkbox"/>	+\$0
<b>LA</b>	light ash <input type="checkbox"/>	+\$0
<b>LM</b>	mahogany <input type="checkbox"/>	+\$0
<b>LU</b>	soft white <input type="checkbox"/>	+\$0
<b>MT</b>	medium tone <input type="checkbox"/>	+\$0
<b>SG</b>	slate grey <input type="checkbox"/>	+\$0
<b>WL</b>	sandstone <input type="checkbox"/>	+\$0
<b>WN</b>	warm grey neutral <input type="checkbox"/>	+\$0

# Ellipse-Pull Freestanding Lateral File *continued*

## Step 12. Cushion Top Fabric

For 1" cushion top (TC1) or 2" cushion top (TC2)

See textiles list for fabric numbers. First 2 digits of number indicate fabric line; remaining digit(s) indicate fabric color.

Price Category 1	+\$0
Price Category 2	+\$55
Price Category 3	+\$67
Price Category 4	+\$82
Price Category 7	+\$137
Price Category 9	+\$950
Price Category B	+\$56
Price Category E	+\$139
Price Category G	+\$250
Price Category H	+\$333

## Step 13. Base Height

<b>B1</b>	1"-high base <input type="checkbox"/> A	+\$0
<b>B2</b>	1½"-high base <input type="checkbox"/> A	+\$0
<b>B3</b>	2¼"-high base <input type="checkbox"/> A	+\$0
<b>B4</b>	3¼"-high base <input type="checkbox"/> A	+\$0
<b>BA</b>	1"-high recessed base <input type="checkbox"/> A	+\$32
<b>BB</b>	1½"-high recessed base <input type="checkbox"/> A	+\$32
<b>BC</b>	2¼"-high recessed base <input type="checkbox"/> A	+\$32
<b>BD</b>	3¼"-high recessed base <input type="checkbox"/> A	+\$32
<b>B5</b>	4¼"-high base <input type="checkbox"/> A	+\$32

## Step 14. Counterweight

<b>NO</b>	no counterweight (must gang or anchor) <input type="checkbox"/> A	+\$0
<b>CB</b>	counterweight (recommended) <input type="checkbox"/> A	+\$115

## Step 15. Drawer Interior

<b>9P</b>	front-to-back filing rail <input type="checkbox"/> A	+\$0
<b>9R</b>	side-to-side filing rail <input type="checkbox"/> A	+\$0
<b>9M</b>	3 dividers <input type="checkbox"/> A	+\$0

## Step 16. Overhead Interior

For 1 26¼"-high overhead storage, 3 11¾"-high drawers (4W) or 1 26¼"-high overhead storage, 3 13⅛"-high drawers (4Z)

<b>NS0</b>	no interior option <input type="checkbox"/> A	-\$32
<b>NS1</b>	1 shelf total <input type="checkbox"/> A	+\$0
<b>NS2</b>	2 shelves total <input type="checkbox"/> A	+\$32

# Ellipse-Pull Freestanding Pedestal

F1J-1

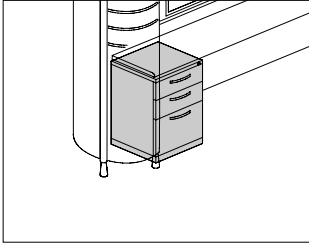

## Product Information

### Description

This 15"-wide freestanding pedestal has ellipse pulls and smooth steel. It has no top or a metal, laminate, or veneer top. 5 base heights are available; all bases include adjustable glides.

Actual pedestal depths are 17<sup>7</sup>/<sub>8</sub>", 21<sup>7</sup>/<sub>8</sub>", or 27<sup>7</sup>/<sub>8</sub>". The pedestal is available in a variety of drawer configurations. File drawers include a file compressor; box drawers include an adjustable drawer divider.

Zephyr laminate edge colors are predetermined for top options T4 and T5:

Top Color—Edge Color

Canyon (D1)—Warm Grey Neutral (WN)

Misted (DC)—Cool Grey Neutral (CL)

Twilight (DF)—Graphite Satin (G2)

Desert (DQ)—Warm Grey Neutral (WN)

### Notes

For additional stability, specify counterweight option (CB).

Stacking pedestals is not recommended.

For work surface on top of 1 or more pedestal files, order file top (TPL or TPV) separately.

Order optional accessories separately:

- Drawer divider (73-1567-D)
- File drawer organizer (73-9874-FDO)
- File drawer organizer (LG901)
- Pencil tray (73-1516-PT)
- Stationery tray (73-7082-SST)

No lock option (NL) can only be specified on pedestals with no top option (NT) or laminate top options (T5 or TL).

For keyed-alike locks, order lock plugs separately. See Keyed-Alike Information in Appendices.

## Dimensions

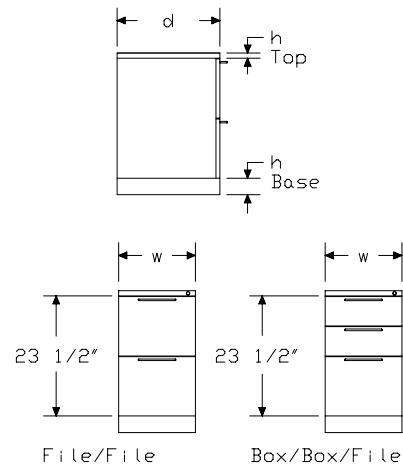

# Ellipse-Pull Freestanding Pedestal

continued

## Specification Information

### Step 1.

**F1J-15**  A

### Step 2. Depth

**18-** 18" deep  A

**22-** 22" deep  A

**28-** 28" deep  A

### Step 3. Configuration

**FF** file/file  A

**BBF** box/box/file  A

### Prices for Steps 1-3.

		FF	BBF
<b>F1J-15</b>	<b>18-</b>	\$640	668
	<b>22-</b>	\$665	693
	<b>28-</b>	\$689	719

### Step 4. Paint/Steel Type

**SS** smooth paint on smooth steel  A +\$0

**TS** smooth paint on textured steel  A +\$0

**XS** textured paint on smooth steel  A +\$0

### Step 5. Case Finish

*For smooth paint on smooth steel (SS) or smooth paint on textured steel (TS)*

Nonmetallic Paint +\$0

Metallic Paint +\$40

### Sand Texture Paint

*For textured paint on smooth steel (XS)*

**7L** dune  A +\$0

**7M** chai  A +\$0

**7N** grass  A +\$0

**7U** blue ridge  A +\$0

**7V** loden  A +\$0

**7W** napa  A +\$0

**7Y** sedona  A +\$0

**7Z** mink  A +\$0

**8T** gull  A +\$0

**8Y** moonbeam  A +\$0

**B4** blue medium  A +\$0

**ZK** cappuccino  A +\$0

### Bright Sand Texture Paint

*For textured paint on smooth steel (XS)*

**91** white  A +\$0

**CL** cool grey neutral  A +\$0

**G1** graphite  A +\$0

**WN** warm grey neutral  A +\$0

### Step 6. Front Finish

*For smooth paint on smooth steel (SS) or smooth paint on textured steel (TS)*

Nonmetallic Paint +\$0

Metallic Paint +\$0

### Sand Texture Paint

*For textured paint on smooth steel (XS)*

**7L** dune  A +\$0

**7M** chai  A +\$0

**7N** grass  A +\$0

**7U** blue ridge  A +\$0

**7V** loden  A +\$0

**7W** napa  A +\$0

**7Y** sedona  A +\$0

**7Z** mink  A +\$0

**8T** gull  A +\$0

**8Y** moonbeam  A +\$0

**B4** blue medium  A +\$0

**ZK** cappuccino  A +\$0

### Bright Sand Texture Paint

*For textured paint on smooth steel (XS)*

**91** white  A +\$0

**CL** cool grey neutral  A +\$0

**G1** graphite  A +\$0

**WN** warm grey neutral  A +\$0

# Ellipse-Pull Freestanding Pedestal

continued

My Studio Environments™ Storage

Step 7. Top		
<b>NT</b>	no top <input type="checkbox"/>	+\$0
<b>T1</b>	1"-high painted metal top with squared edge <input type="checkbox"/>	+\$0
<b>T2</b>	1 1/4"-high painted metal top with squared edge <input type="checkbox"/>	+\$0
<b>T3</b>	1 1/4"-high painted metal top with radius edge <input type="checkbox"/>	+\$48
<b>TL</b>	1 1/4"-high laminate top with vinyl edge <input type="checkbox"/>	+\$63
<b>T4</b>	1 1/4"-high laminate top with squared edge <input type="checkbox"/>	+\$111
<b>TR</b>	1 1/4"-high recut veneer top <input type="checkbox"/>	+\$112
<b>J3</b>	1 1/4"-high cathedral recut veneer top <input type="checkbox"/>	+\$127
<b>TF</b>	1 1/4"-high wood veneer top <input type="checkbox"/>	+\$136
<b>T5</b>	1 1/4"-high laminate top with radius edge <input type="checkbox"/>	+\$220
<b>TV1</b>	1 1/8"-high wood veneer top and wood composite edge with oversail front <input type="checkbox"/>	+\$232

Step 8. Lock		
<i>For no top (NT), 1 1/4"-high laminate top with vinyl edge (TL), 1 1/4"-high laminate top with radius edge (T5), or 1 1/8"-high wood veneer top and wood composite edge with oversail front (TV1)</i>		
<b>NL</b>	no lock <input type="checkbox"/>	-\$26

<i>For 1"-high painted metal top with squared edge (T1), 1 1/4"-high painted metal top with squared edge (T2), 1 1/4"-high painted metal top with radius edge (T3), 1 1/4"-high laminate top with squared edge (T4), 1 1/4"-high recut veneer top (TR), 1 1/4"-high cathedral recut veneer top (J3), or 1 1/4"-high wood veneer top (TF)</i>		
<b>KA</b>	keyed alike <input type="checkbox"/>	+\$0
<b>KC</b>	keyed differently, chrome <input type="checkbox"/>	+\$0
<b>KD</b>	keyed differently, black <input type="checkbox"/>	+\$0

Step 9.		
Top Finish: Solid-Color Laminate		
<i>For 1 1/4"-high laminate top with vinyl edge (TL)</i>		
<b>8Q</b>	folkstone grey <input type="checkbox"/>	+\$0
<b>91</b>	white <input type="checkbox"/>	+\$0
<b>CL</b>	cool grey neutral <input type="checkbox"/>	+\$0
<b>HF</b>	inner tone light <input type="checkbox"/>	+\$0
<b>HT</b>	inner tone <input type="checkbox"/>	+\$0
<b>LT</b>	light tone <input type="checkbox"/>	+\$0
<b>LU</b>	soft white <input type="checkbox"/>	+\$0
<b>WL</b>	sandstone <input type="checkbox"/>	+\$0
<b>WN</b>	warm grey neutral <input type="checkbox"/>	+\$0

Top Finish: Fiber Laminate		
<i>For 1 1/4"-high laminate top with vinyl edge (TL)</i>		
<b>1X</b>	vanilla <input type="checkbox"/>	+\$0
<b>2X</b>	wheat <input type="checkbox"/>	+\$0
<b>3X</b>	celery <input type="checkbox"/>	+\$0
<b>4X</b>	coriander <input type="checkbox"/>	+\$0
<b>5X</b>	chamomile <input type="checkbox"/>	+\$0
<b>6X</b>	cinnamon <input type="checkbox"/>	+\$0
<b>7X</b>	cardamom <input type="checkbox"/>	+\$0
<b>8X</b>	kale <input type="checkbox"/>	+\$0

Top Finish: Frosted Laminate		
<i>For 1 1/4"-high laminate top with vinyl edge (TL)</i>		
<b>J4</b>	frosted light grey <input type="checkbox"/>	+\$0
<b>J5</b>	frosted inner tone light <input type="checkbox"/>	+\$0
<b>J6</b>	frosted slate grey <input type="checkbox"/>	+\$0
<b>J7</b>	frosted medium tone <input type="checkbox"/>	+\$0
<b>J8</b>	frosted black <input type="checkbox"/>	+\$0

Top Finish: Wood-Grain Laminate		
<i>For 1 1/4"-high laminate top with vinyl edge (TL)</i>		
<b>LA</b>	light ash <input type="checkbox"/>	+\$0
<b>LM</b>	mahogany <input type="checkbox"/>	+\$0

Top Finish: Zephyr Laminate		
<i>For 1 1/4"-high laminate top with vinyl edge (TL)</i>		
<b>D1</b>	canyon <input type="checkbox"/>	+\$0
<b>DC</b>	misted <input type="checkbox"/>	+\$0
<b>DF</b>	twilight <input type="checkbox"/>	+\$0
<b>DQ</b>	desert <input type="checkbox"/>	+\$0

Top/Edge Finish: Solid-Color Laminate		
<i>For 1 1/4"-high laminate top with squared edge (T4) or 1 1/4"-high laminate top with radius edge (T5)</i>		
<b>8Q</b>	folkstone grey <input type="checkbox"/>	+\$0
<b>91</b>	white <input type="checkbox"/>	+\$0
<b>CL</b>	cool grey neutral <input type="checkbox"/>	+\$0
<b>HF</b>	inner tone light <input type="checkbox"/>	+\$0
<b>HT</b>	inner tone <input type="checkbox"/>	+\$0
<b>LT</b>	light tone <input type="checkbox"/>	+\$0
<b>LU</b>	soft white <input type="checkbox"/>	+\$0
<b>WL</b>	sandstone <input type="checkbox"/>	+\$0
<b>WN</b>	warm grey neutral <input type="checkbox"/>	+\$0

# Ellipse-Pull Freestanding Pedestal

continued

## Top/Edge Finish: Fiber Laminate

For 1 1/4"-high laminate top with squared edge (T4) or 1 1/4"-high laminate top with radius edge (T5)

<b>1X</b>	vanilla <input type="checkbox"/>	+\$0
<b>2X</b>	wheat <input type="checkbox"/>	+\$0
<b>3X</b>	celery <input type="checkbox"/>	+\$0
<b>4X</b>	coriander <input type="checkbox"/>	+\$0
<b>5X</b>	chamomile <input type="checkbox"/>	+\$0
<b>6X</b>	cinnamon <input type="checkbox"/>	+\$0
<b>7X</b>	cardamom <input type="checkbox"/>	+\$0
<b>8X</b>	kale <input type="checkbox"/>	+\$0

## Top/Edge Finish: Frosted Laminate

For 1 1/4"-high laminate top with squared edge (T4) or 1 1/4"-high laminate top with radius edge (T5)

<b>J4</b>	frosted light grey <input type="checkbox"/>	+\$0
<b>J5</b>	frosted inner tone light <input type="checkbox"/>	+\$0
<b>J6</b>	frosted slate grey <input type="checkbox"/>	+\$0
<b>J7</b>	frosted medium tone <input type="checkbox"/>	+\$0
<b>J8</b>	frosted black <input type="checkbox"/>	+\$0

## Top/Edge Finish: Wood-Grain Laminate

For 1 1/4"-high laminate top with squared edge (T4) or 1 1/4"-high laminate top with radius edge (T5)

<b>LA</b>	light ash <input type="checkbox"/>	+\$0
<b>LM</b>	mahogany <input type="checkbox"/>	+\$0

## Top/Edge Finish: Zephyr Laminate

For 1 1/4"-high laminate top with squared edge (T4) or 1 1/4"-high laminate top with radius edge (T5)

<b>D1</b>	canyon <input type="checkbox"/>	+\$0
<b>DC</b>	misted <input type="checkbox"/>	+\$0
<b>DF</b>	twilight <input type="checkbox"/>	+\$0
<b>DQ</b>	desert <input type="checkbox"/>	+\$0

## Veneer Top Finish: Recut Veneer

For 1 1/4"-high recut veneer top (TR)

<b>RA</b>	light ash <input type="checkbox"/>	+\$0
<b>RK</b>	mahogany dark <input type="checkbox"/>	+\$0
<b>RM</b>	mahogany <input type="checkbox"/>	+\$0

## Veneer Top Finish: Recut Veneer

For 1 1/4"-high cathedral recut veneer top (J3)

<b>DU</b>	cathedral recut natural maple <input type="checkbox"/>	+\$0
<b>HU</b>	cathedral recut light anigre <input type="checkbox"/>	+\$0
<b>JU</b>	cathedral recut aged cherry <input type="checkbox"/>	+\$0
<b>VU</b>	cathedral recut light brown walnut <input type="checkbox"/>	+\$0
<b>WU</b>	cathedral recut walnut on cherry <input type="checkbox"/>	+\$0
<b>XU</b>	cathedral recut medium red cherry <input type="checkbox"/>	+\$0
<b>ZU</b>	cathedral recut chocolate brown sapele <input type="checkbox"/>	+\$0

## Veneer Top Finish: Wood Veneer

For 1 1/4"-high wood veneer top (TF)

<b>V3</b>	cherry <input type="checkbox"/>	+\$15
<b>Z3</b>	warm red cherry <input type="checkbox"/>	+\$15
<b>Z5</b>	maple <input type="checkbox"/>	+\$15
<b>2U</b>	light brown walnut <input type="checkbox"/>	+\$20
<b>3U</b>	medium red cherry <input type="checkbox"/>	+\$20
<b>6U</b>	chocolate brown sapele <input type="checkbox"/>	+\$20
<b>ED</b>	aged cherry <input type="checkbox"/>	+\$20
<b>EG</b>	medium brown walnut <input type="checkbox"/>	+\$20
<b>EK</b>	medium red walnut <input type="checkbox"/>	+\$20
<b>EY</b>	light anigre <input type="checkbox"/>	+\$20
<b>UL</b>	natural maple <input type="checkbox"/>	+\$20
<b>UQ</b>	light cherry <input type="checkbox"/>	+\$20
<b>UV</b>	red cherry <input type="checkbox"/>	+\$20
<b>UX</b>	walnut on cherry <input type="checkbox"/>	+\$20

## Veneer Top Finish: Wood Veneer

For 1 1/8"-high wood veneer top and wood composite edge with oversail front (TV1)

<b>ED</b>	aged cherry <input type="checkbox"/>	+\$20
<b>EG</b>	medium brown walnut <input type="checkbox"/>	+\$20
<b>EK</b>	medium red walnut <input type="checkbox"/>	+\$20
<b>EY</b>	light anigre <input type="checkbox"/>	+\$20
<b>UL</b>	natural maple <input type="checkbox"/>	+\$20
<b>UQ</b>	light cherry <input type="checkbox"/>	+\$20
<b>UV</b>	red cherry <input type="checkbox"/>	+\$20
<b>UX</b>	walnut on cherry <input type="checkbox"/>	+\$20

My Studio Environments™ Storage

# Ellipse-Pull Freestanding Pedestal

continued

My Studio Environments™ Storage

## Step 10. Edge Finish

For 1¼"-high laminate top with vinyl edge (TL)

<b>8Q</b>	folkstone grey <input type="checkbox"/>	+\$0
<b>91</b>	white <input type="checkbox"/>	+\$0
<b>BU</b>	black umber <input type="checkbox"/>	+\$0
<b>CL</b>	cool grey neutral <input type="checkbox"/>	+\$0
<b>CM</b>	cinnamon <input type="checkbox"/>	+\$0
<b>CO</b>	chamomile <input type="checkbox"/>	+\$0
<b>G2</b>	graphite satin <input type="checkbox"/>	+\$0
<b>HF</b>	inner tone light <input type="checkbox"/>	+\$0
<b>HT</b>	inner tone <input type="checkbox"/>	+\$0
<b>LA</b>	light ash <input type="checkbox"/>	+\$0
<b>LM</b>	mahogany <input type="checkbox"/>	+\$0
<b>LU</b>	soft white <input type="checkbox"/>	+\$0
<b>MT</b>	medium tone <input type="checkbox"/>	+\$0
<b>SG</b>	slate grey <input type="checkbox"/>	+\$0
<b>WL</b>	sandstone <input type="checkbox"/>	+\$0
<b>WN</b>	warm grey neutral <input type="checkbox"/>	+\$0

## Step 11. Base Height

<b>B1</b>	1"-high base <input type="checkbox"/>	+\$0
<b>B2</b>	1½"-high base <input type="checkbox"/>	+\$0
<b>B3</b>	2¼"-high base <input type="checkbox"/>	+\$0
<b>B4</b>	3¼"-high base <input type="checkbox"/>	+\$0
<b>BA</b>	1"-high recessed base <input type="checkbox"/>	+\$32
<b>BB</b>	1½"-high recessed base <input type="checkbox"/>	+\$32
<b>BC</b>	2¼"-high recessed base <input type="checkbox"/>	+\$32
<b>BD</b>	3¼"-high recessed base <input type="checkbox"/>	+\$32
<b>B5</b>	4¼"-high base <input type="checkbox"/>	+\$32

## Step 12. Counterweight

<b>NO</b>	no counterweight <input type="checkbox"/>	+\$0
<b>CB</b>	counterweight <input type="checkbox"/>	+\$88

## Step 13. Compressor

For file/file (FF)

<b>DC</b>	hanging rail, no compressor <input type="checkbox"/>	-\$24
<b>C</b>	standard compressor <input type="checkbox"/>	+\$0

For box/box/file (BBF)

<b>DC</b>	hanging rail, no compressor <input type="checkbox"/>	-\$12
<b>C</b>	standard compressor <input type="checkbox"/>	+\$0

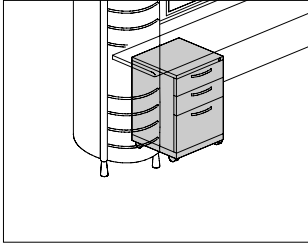

**Product Information**

**Description**

This 15"-wide mobile pedestal has ellipse pulls and smooth steel. It has no top or a metal, laminate, or veneer top. The pedestal has a 2 1/2"-high base with casters and counterweights.

Actual pedestal depths are 17 7/8", 21 7/8", or 27 7/8". The pedestal is available in a variety of drawer configurations. File drawers include a file compressor; box drawers include an adjustable drawer divider. The pedestal with squared-edge metal top is available with a hand grip; the 22"- and 28"-deep pedestals with squared-edge metal tops are available with transit handles.

Zephyr laminate edge colors are predetermined for top options T4 and T5:

Top Color—Edge Color

Canyon (D1)—Warm Grey Neutral (WN)

Misted (DC)—Cool Grey Neutral (CL)

Twilight (DF)—Graphite Satin (G2)

Desert (DQ)—Warm Grey Neutral (WN)

**Notes**

Order optional accessories separately:

- Drawer divider (73-1567-D)
- File drawer organizer (73-9874-FDO)
- File drawer organizer (LG901)
- Pencil tray (73-1516-PT)
- Stationery tray (73-7082-SST)

No lock option (NL) can only be specified on pedestals with no top option (NT) or laminate top options (T5 or TL).

For keyed-alike locks, order lock plugs separately. See Keyed-Alike Information in Appendices.

**Dimensions**

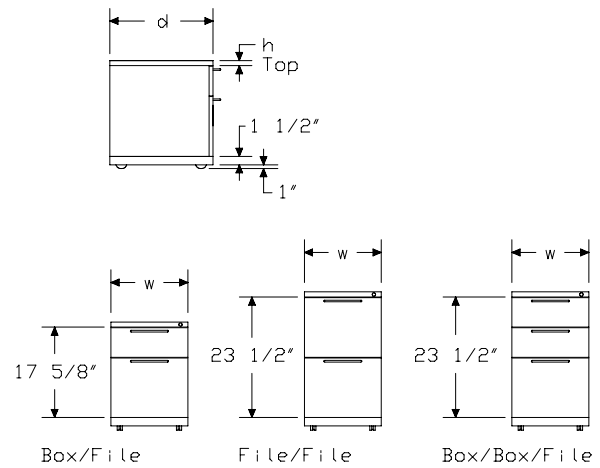

# Ellipse-Pull Mobile Pedestal

continued

My Studio Environments™ Storage

## Specification Information

### Step 1.

**M1J-15**

### Step 2. Depth

**18-** 18" deep

**22-** 22" deep

**28-** 28" deep

### Step 3. Configuration

**BF** box/file

**FF** file/file

**BBF** box/box/file

### Prices for Steps 1-3.

		BF	FF	BBF
<b>M1J-15</b>	<b>18-</b>	\$681	779	810
	<b>22-</b>	\$697	802	832
	<b>28-</b>	\$723	839	861

### Step 4. Paint/Steel Type

**SS** smooth paint on smooth steel  +\$0

**TS** smooth paint on textured steel  +\$0

**XS** textured paint on smooth steel  +\$0

### Step 5. Case Finish

*For smooth paint on smooth steel (SS) or smooth paint on textured steel (TS)*

Nonmetallic Paint +\$0

Metallic Paint +\$40

### Sand Texture Paint

*For textured paint on smooth steel (XS)*

<b>7L</b>	dune <input type="checkbox"/>	+\$0
<b>7M</b>	chai <input type="checkbox"/>	+\$0
<b>7N</b>	grass <input type="checkbox"/>	+\$0
<b>7U</b>	blue ridge <input type="checkbox"/>	+\$0
<b>7V</b>	loden <input type="checkbox"/>	+\$0
<b>7W</b>	napa <input type="checkbox"/>	+\$0
<b>7Y</b>	sedona <input type="checkbox"/>	+\$0
<b>7Z</b>	mink <input type="checkbox"/>	+\$0
<b>8T</b>	gull <input type="checkbox"/>	+\$0
<b>8Y</b>	moonbeam <input type="checkbox"/>	+\$0
<b>B4</b>	blue medium <input type="checkbox"/>	+\$0
<b>ZK</b>	cappuccino <input type="checkbox"/>	+\$0

### Bright Sand Texture Paint

*For textured paint on smooth steel (XS)*

<b>91</b>	white <input type="checkbox"/>	+\$0
<b>CL</b>	cool grey neutral <input type="checkbox"/>	+\$0
<b>G1</b>	graphite <input type="checkbox"/>	+\$0
<b>WN</b>	warm grey neutral <input type="checkbox"/>	+\$0

### Step 6. Front Finish

*For smooth paint on smooth steel (SS) or smooth paint on textured steel (TS)*

Nonmetallic Paint +\$0

Metallic Paint +\$0

### Sand Texture Paint

*For textured paint on smooth steel (XS)*

<b>7L</b>	dune <input type="checkbox"/>	+\$0
<b>7M</b>	chai <input type="checkbox"/>	+\$0
<b>7N</b>	grass <input type="checkbox"/>	+\$0
<b>7U</b>	blue ridge <input type="checkbox"/>	+\$0
<b>7V</b>	loden <input type="checkbox"/>	+\$0
<b>7W</b>	napa <input type="checkbox"/>	+\$0
<b>7Y</b>	sedona <input type="checkbox"/>	+\$0
<b>7Z</b>	mink <input type="checkbox"/>	+\$0
<b>8T</b>	gull <input type="checkbox"/>	+\$0
<b>8Y</b>	moonbeam <input type="checkbox"/>	+\$0
<b>B4</b>	blue medium <input type="checkbox"/>	+\$0
<b>ZK</b>	cappuccino <input type="checkbox"/>	+\$0

### Bright Sand Texture Paint

*For textured paint on smooth steel (XS)*

<b>91</b>	white <input type="checkbox"/>	+\$0
<b>CL</b>	cool grey neutral <input type="checkbox"/>	+\$0
<b>G1</b>	graphite <input type="checkbox"/>	+\$0
<b>WN</b>	warm grey neutral <input type="checkbox"/>	+\$0

# Ellipse-Pull Mobile Pedestal

continued

## Step 7. Top

<b>NT</b>	no top <input type="checkbox"/>	+\$0
<b>T1</b>	1"-high painted metal top with squared edge <input type="checkbox"/>	+\$0
<b>T2</b>	1 <sup>1</sup> / <sub>4</sub> "-high painted metal top with squared edge <input type="checkbox"/>	+\$0
<b>T3</b>	1 <sup>1</sup> / <sub>4</sub> "-high painted metal top with radius edge <input type="checkbox"/>	+\$48
<b>TL</b>	1 <sup>1</sup> / <sub>4</sub> "-high laminate top with vinyl edge <input type="checkbox"/>	+\$63
<b>T4</b>	1 <sup>1</sup> / <sub>4</sub> "-high laminate top with squared edge <input type="checkbox"/>	+\$111
<b>TR</b>	1 <sup>1</sup> / <sub>4</sub> "-high recut veneer top <input type="checkbox"/>	+\$112
<b>J3</b>	1 <sup>1</sup> / <sub>4</sub> "-high cathedral recut veneer top <input type="checkbox"/>	+\$127
<b>TF</b>	1 <sup>1</sup> / <sub>4</sub> "-high wood veneer top <input type="checkbox"/>	+\$136
<b>T5</b>	1 <sup>1</sup> / <sub>4</sub> "-high laminate top with radius edge <input type="checkbox"/>	+\$220
<b>TV1</b>	1 <sup>1</sup> / <sub>8</sub> "-high wood veneer top and wood composite edge with oversail front <input type="checkbox"/>	+\$232

## Step 8. Lock

For no top (NT), 1<sup>1</sup>/<sub>4</sub>"-high laminate top with vinyl edge (TL), 1<sup>1</sup>/<sub>4</sub>"-high laminate top with radius edge (T5), or 1<sup>1</sup>/<sub>8</sub>"-high wood veneer top and wood composite edge with oversail front (TV1)

<b>NL</b>	no lock <input type="checkbox"/>	-\$26
-----------	----------------------------------	-------

For 1"-high painted metal top with squared edge (T1), 1<sup>1</sup>/<sub>4</sub>"-high painted metal top with squared edge (T2), 1<sup>1</sup>/<sub>4</sub>"-high painted metal top with radius edge (T3), 1<sup>1</sup>/<sub>4</sub>"-high laminate top with squared edge (T4), 1<sup>1</sup>/<sub>4</sub>"-high recut veneer top (TR), 1<sup>1</sup>/<sub>4</sub>"-high cathedral recut veneer top (J3), or 1<sup>1</sup>/<sub>4</sub>"-high wood veneer top (TF)

<b>KA</b>	keyed alike <input type="checkbox"/>	+\$0
<b>KC</b>	keyed differently, chrome <input type="checkbox"/>	+\$0
<b>KD</b>	keyed differently, black <input type="checkbox"/>	+\$0

## Step 9.

### Top Finish: Solid-Color Laminate

For 1<sup>1</sup>/<sub>4</sub>"-high laminate top with vinyl edge (TL)

<b>8Q</b>	folkstone grey <input type="checkbox"/>	+\$0
<b>91</b>	white <input type="checkbox"/>	+\$0
<b>CL</b>	cool grey neutral <input type="checkbox"/>	+\$0
<b>HF</b>	inner tone light <input type="checkbox"/>	+\$0
<b>HT</b>	inner tone <input type="checkbox"/>	+\$0
<b>LT</b>	light tone <input type="checkbox"/>	+\$0
<b>LU</b>	soft white <input type="checkbox"/>	+\$0
<b>WL</b>	sandstone <input type="checkbox"/>	+\$0
<b>WN</b>	warm grey neutral <input type="checkbox"/>	+\$0

### Top Finish: Fiber Laminate

For 1<sup>1</sup>/<sub>4</sub>"-high laminate top with vinyl edge (TL)

<b>1X</b>	vanilla <input type="checkbox"/>	+\$0
<b>2X</b>	wheat <input type="checkbox"/>	+\$0
<b>3X</b>	celery <input type="checkbox"/>	+\$0
<b>4X</b>	coriander <input type="checkbox"/>	+\$0
<b>5X</b>	chamomile <input type="checkbox"/>	+\$0
<b>6X</b>	cinnamon <input type="checkbox"/>	+\$0
<b>7X</b>	cardamom <input type="checkbox"/>	+\$0
<b>8X</b>	kale <input type="checkbox"/>	+\$0

### Top Finish: Frosted Laminate

For 1<sup>1</sup>/<sub>4</sub>"-high laminate top with vinyl edge (TL)

<b>J4</b>	frosted light grey <input type="checkbox"/>	+\$0
<b>J5</b>	frosted inner tone light <input type="checkbox"/>	+\$0
<b>J6</b>	frosted slate grey <input type="checkbox"/>	+\$0
<b>J7</b>	frosted medium tone <input type="checkbox"/>	+\$0
<b>J8</b>	frosted black <input type="checkbox"/>	+\$0

### Top Finish: Wood-Grain Laminate

For 1<sup>1</sup>/<sub>4</sub>"-high laminate top with vinyl edge (TL)

<b>LA</b>	light ash <input type="checkbox"/>	+\$0
<b>LM</b>	mahogany <input type="checkbox"/>	+\$0

### Top Finish: Zephyr Laminate

For 1<sup>1</sup>/<sub>4</sub>"-high laminate top with vinyl edge (TL)

<b>D1</b>	canyon <input type="checkbox"/>	+\$0
<b>DC</b>	misted <input type="checkbox"/>	+\$0
<b>DF</b>	twilight <input type="checkbox"/>	+\$0
<b>DQ</b>	desert <input type="checkbox"/>	+\$0

### Top/Edge Finish: Solid-Color Laminate

For 1<sup>1</sup>/<sub>4</sub>"-high laminate top with squared edge (T4) or 1<sup>1</sup>/<sub>4</sub>"-high laminate top with radius edge (T5)

<b>8Q</b>	folkstone grey <input type="checkbox"/>	+\$0
<b>91</b>	white <input type="checkbox"/>	+\$0
<b>CL</b>	cool grey neutral <input type="checkbox"/>	+\$0
<b>HF</b>	inner tone light <input type="checkbox"/>	+\$0
<b>HT</b>	inner tone <input type="checkbox"/>	+\$0
<b>LT</b>	light tone <input type="checkbox"/>	+\$0
<b>LU</b>	soft white <input type="checkbox"/>	+\$0
<b>WL</b>	sandstone <input type="checkbox"/>	+\$0
<b>WN</b>	warm grey neutral <input type="checkbox"/>	+\$0

My Studio Environments™ Storage

# Ellipse-Pull Mobile Pedestal

continued

My Studio Environments™ Storage

## Top/Edge Finish: Fiber Laminate

For 1 1/4"-high laminate top with squared edge (T4) or 1 1/4"-high laminate top with radius edge (T5)

<b>1X</b>	vanilla <input type="checkbox"/>	+\$0
<b>2X</b>	wheat <input type="checkbox"/>	+\$0
<b>3X</b>	celery <input type="checkbox"/>	+\$0
<b>4X</b>	coriander <input type="checkbox"/>	+\$0
<b>5X</b>	chamomile <input type="checkbox"/>	+\$0
<b>6X</b>	cinnamon <input type="checkbox"/>	+\$0
<b>7X</b>	cardamom <input type="checkbox"/>	+\$0
<b>8X</b>	kale <input type="checkbox"/>	+\$0

## Top/Edge Finish: Frosted Laminate

For 1 1/4"-high laminate top with squared edge (T4) or 1 1/4"-high laminate top with radius edge (T5)

<b>J4</b>	frosted light grey <input type="checkbox"/>	+\$0
<b>J5</b>	frosted inner tone light <input type="checkbox"/>	+\$0
<b>J6</b>	frosted slate grey <input type="checkbox"/>	+\$0
<b>J7</b>	frosted medium tone <input type="checkbox"/>	+\$0
<b>J8</b>	frosted black <input type="checkbox"/>	+\$0

## Top/Edge Finish: Wood-Grain Laminate

For 1 1/4"-high laminate top with squared edge (T4) or 1 1/4"-high laminate top with radius edge (T5)

<b>LA</b>	light ash <input type="checkbox"/>	+\$0
<b>LM</b>	mahogany <input type="checkbox"/>	+\$0

## Top/Edge Finish: Zephyr Laminate

For 1 1/4"-high laminate top with squared edge (T4) or 1 1/4"-high laminate top with radius edge (T5)

<b>D1</b>	canyon <input type="checkbox"/>	+\$0
<b>DC</b>	misted <input type="checkbox"/>	+\$0
<b>DF</b>	twilight <input type="checkbox"/>	+\$0
<b>DQ</b>	desert <input type="checkbox"/>	+\$0

## Veneer Top Finish: Recut Veneer

For 1 1/4"-high recut veneer top (TR)

<b>RA</b>	light ash <input type="checkbox"/>	+\$0
<b>RK</b>	mahogany dark <input type="checkbox"/>	+\$0
<b>RM</b>	mahogany <input type="checkbox"/>	+\$0

## Veneer Top Finish: Recut Veneer

For 1 1/4"-high cathedral recut veneer top (J3)

<b>DU</b>	cathedral recut natural maple <input type="checkbox"/>	+\$0
<b>HU</b>	cathedral recut light anigre <input type="checkbox"/>	+\$0
<b>JU</b>	cathedral recut aged cherry <input type="checkbox"/>	+\$0
<b>VU</b>	cathedral recut light brown walnut <input type="checkbox"/>	+\$0
<b>WU</b>	cathedral recut walnut on cherry <input type="checkbox"/>	+\$0
<b>XU</b>	cathedral recut medium red cherry <input type="checkbox"/>	+\$0
<b>ZU</b>	cathedral recut chocolate brown sapele <input type="checkbox"/>	+\$0

## Veneer Top Finish: Wood Veneer

For 1 1/4"-high wood veneer top (TF)

<b>V3</b>	cherry <input type="checkbox"/>	+\$15
<b>Z3</b>	warm red cherry <input type="checkbox"/>	+\$15
<b>Z5</b>	maple <input type="checkbox"/>	+\$15
<b>2U</b>	light brown walnut <input type="checkbox"/>	+\$20
<b>3U</b>	medium red cherry <input type="checkbox"/>	+\$20
<b>6U</b>	chocolate brown sapele <input type="checkbox"/>	+\$20
<b>ED</b>	aged cherry <input type="checkbox"/>	+\$20
<b>EG</b>	medium brown walnut <input type="checkbox"/>	+\$20
<b>EK</b>	medium red walnut <input type="checkbox"/>	+\$20
<b>EY</b>	light anigre <input type="checkbox"/>	+\$20
<b>UL</b>	natural maple <input type="checkbox"/>	+\$20
<b>UQ</b>	light cherry <input type="checkbox"/>	+\$20
<b>UV</b>	red cherry <input type="checkbox"/>	+\$20
<b>UX</b>	walnut on cherry <input type="checkbox"/>	+\$20

## Veneer Top Finish: Wood Veneer

For 1 1/8"-high wood veneer top and wood composite edge with oversail front (TV1)

<b>ED</b>	aged cherry <input type="checkbox"/>	+\$20
<b>EG</b>	medium brown walnut <input type="checkbox"/>	+\$20
<b>EK</b>	medium red walnut <input type="checkbox"/>	+\$20
<b>EY</b>	light anigre <input type="checkbox"/>	+\$20
<b>UL</b>	natural maple <input type="checkbox"/>	+\$20
<b>UQ</b>	light cherry <input type="checkbox"/>	+\$20
<b>UV</b>	red cherry <input type="checkbox"/>	+\$20
<b>UX</b>	walnut on cherry <input type="checkbox"/>	+\$20

# Ellipse-Pull Mobile Pedestal

continued

## Step 10. Edge Finish

For 1<sup>1</sup>/<sub>4</sub>"-high laminate top with vinyl edge (TL)

<b>8Q</b>	folkstone grey <input type="checkbox"/>	+\$0
<b>91</b>	white <input type="checkbox"/>	+\$0
<b>BU</b>	black umber <input type="checkbox"/>	+\$0
<b>CL</b>	cool grey neutral <input type="checkbox"/>	+\$0
<b>CM</b>	cinnamon <input type="checkbox"/>	+\$0
<b>CO</b>	chamomile <input type="checkbox"/>	+\$0
<b>G2</b>	graphite satin <input type="checkbox"/>	+\$0
<b>HF</b>	inner tone light <input type="checkbox"/>	+\$0
<b>HT</b>	inner tone <input type="checkbox"/>	+\$0
<b>LA</b>	light ash <input type="checkbox"/>	+\$0
<b>LM</b>	mahogany <input type="checkbox"/>	+\$0
<b>LU</b>	soft white <input type="checkbox"/>	+\$0
<b>MT</b>	medium tone <input type="checkbox"/>	+\$0
<b>SG</b>	slate grey <input type="checkbox"/>	+\$0
<b>WL</b>	sandstone <input type="checkbox"/>	+\$0
<b>WN</b>	warm grey neutral <input type="checkbox"/>	+\$0

## Step 11. Handle

For 18" deep (18-) with 1"-high painted metal top with squared edge (T1)  
or 1<sup>1</sup>/<sub>4</sub>"-high painted metal top with squared edge (T2)

<b>HN</b>	no hand grip or transit handle <input type="checkbox"/>	+\$0
<b>H1</b>	hand grip only <input type="checkbox"/>	+\$48

For 22" deep (22-) with 1"-high painted metal top with squared edge (T1)  
or 1<sup>1</sup>/<sub>4</sub>"-high painted metal top with squared edge (T2); 28" deep (28-)  
with 1"-high painted metal top with squared edge (T1) or 1<sup>1</sup>/<sub>4</sub>"-high  
painted metal top with squared edge (T2)

<b>HN</b>	no hand grip or transit handle <input type="checkbox"/>	+\$0
<b>H1</b>	hand grip only <input type="checkbox"/>	+\$48
<b>H2</b>	transit handle only <input type="checkbox"/>	+\$95
<b>H3</b>	hand grip and transit handle <input type="checkbox"/>	+\$142

## Step 12. Compressor

For box/file (BF) or box/box/file (BBF)

<b>DC</b>	hanging rail, no compressor <input type="checkbox"/>	-\$12
<b>C</b>	standard compressor <input type="checkbox"/>	+\$0

For file/file (FF)

<b>DC</b>	hanging rail, no compressor <input type="checkbox"/>	-\$24
<b>C</b>	standard compressor <input type="checkbox"/>	+\$0

## Ellipse-Pull Storage Case

4J-30

4J-36

4J-42

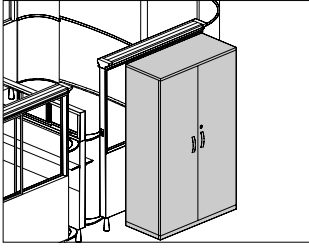

### Product Information

#### Description

This freestanding, lockable storage case has ellipse pulls, smooth steel, and is available in 3 widths, 2 depths, and 9 heights. It has a metal, cushion, laminate, or veneer top. The case has hinged doors that open to 110° and various interior configurations. 5 base heights are available; all bases include adjustable glides.

Actual storage case widths are 29<sup>7</sup>/<sub>8</sub>" , 35<sup>7</sup>/<sub>8</sub>" , or 41<sup>7</sup>/<sub>8</sub>" ; actual depths are 17<sup>7</sup>/<sub>8</sub>" and 19<sup>7</sup>/<sub>8</sub>" . The 4<sup>3</sup>/<sub>4</sub>" -high mobile base has a 1<sup>1</sup>/<sub>2</sub>" -high base frame with 3<sup>1</sup>/<sub>4</sub>" -high outset casters. The 2 swivel and 2 fixed casters must be field installed.

Zephyr laminate edge colors are predetermined for top options T4 and T5:

Top Color—Edge Color

Canyon (D1)—Warm Grey Neutral (WN)

Misted (DC)—Cool Grey Neutral (CL)

Twilight (DF)—Graphite Satin (G2)

Desert (DQ)—Warm Grey Neutral (WN)

#### Notes

Coat rod and shelf option (WC) available only for 66"- and 69"-high cases.

Coat rod with 3 shelves option (W) available only for 66"- and 69"-high cases with T2 top.

Mobile base (B9) option available only on 26"-, 29"-, 38"-, and 42"-high cases.

Dimensional illustrations do not include all possible configurations.

For cushion tops TC1 and TC2, a 1" metal top is included.

Cushion top accepts Customer's Own Material (COM). Yardage is estimated for nondirectional, 54"-wide fabrics. When ordering more than 1 cushion, round up total yardage requirement to next whole yard of fabric.

Width—Yardage

30"—1.05

36"—1.22

42"—1.40

For information on multiple quantities or directional fabrics, contact COM Department. See Order Information in Appendices.

For keyed-alike locks, order lock plugs separately. See Keyed-Alike Information in Appendices.

### Dimensions

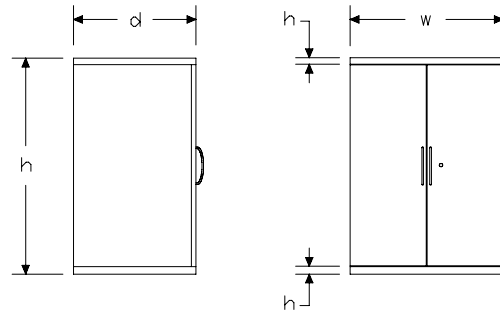

Ellipse-Pull Storage Case *continued*

**Specification Information**

Step 1.

4J-  A

Step 2. Width

30 30" wide  A

36 36" wide  A

42 42" wide  A

Step 3. Depth

18- 18" deep  A

20- 20" deep  A

Step 4. Case Height

26 23½" high  A

29 26¼" high  A

38 35¼" high  A

42 39¾" high  A

50 47" high  A

55 52½" high  A

63 60⅛" high  A

66 62⅞" high  A

69 65⅝" high  A

Prices for Steps 1-4.

		26	29	38	42	50	55	63
4J-30	18-	\$572	607	664	710	806	843	876
	20-	\$572	607	664	710	806	843	876

4J-36	18-	\$653	688	744	790	886	922	955
	20-	\$653	688	744	790	886	922	955

4J-42	18-	\$746	782	836	883	979	1014	1050
	20-	\$746	782	836	883	979	1014	1050

		66	69
4J-30	18-	\$898	945
	20-	\$898	945

4J-36	18-	\$979	1025
	20-	\$979	1025

4J-42	18-	\$1073	1115
	20-	\$1073	1115

Step 5. Paint/Steel Type

SS smooth paint on smooth steel  A +\$0

TS smooth paint on textured steel  A +\$0

XS textured paint on smooth steel  A +\$0

Step 6. Surface Finish

*For smooth paint on smooth steel (SS) or smooth paint on textured steel (TS)*

Nonmetallic Paint +\$0

Metallic Paint +\$75

Sand Texture Paint

*For textured paint on smooth steel (XS)*

7L dune  A +\$0

7M chai  A +\$0

7N grass  A +\$0

7U blue ridge  A +\$0

7V loden  A +\$0

7W napa  A +\$0

7Y sedona  A +\$0

7Z mink  A +\$0

8T gull  A +\$0

8Y moonbeam  A +\$0

B4 blue medium  A +\$0

ZK cappuccino  A +\$0

Bright Sand Texture Paint

*For textured paint on smooth steel (XS)*

91 white  A +\$0

CL cool grey neutral  A +\$0

G1 graphite  A +\$0

WN warm grey neutral  A +\$0

Step 7. Interior

*Coat rod with three shelves (W) only available with 1¼"-high painted metal top (T2).*

*For 23½" high (26), 26¼" high (29), 35¼" high (38), 39¾" high (42), 47" high (50), 52½" high (55), or 60⅛" high (63)*

NS0 no interior option  A +\$0

NS1 1 shelf total  A +\$39

NS2 2 shelves total  A +\$78

NS3 3 shelves total  A +\$117

NS4 4 shelves total  A +\$156

9L center bar for computer printout binders  A +\$58

Ellipse-Pull Storage Case *continued*

*For 62<sup>7</sup>/<sub>8</sub>" high (66) or 65<sup>5</sup>/<sub>8</sub>" high (69)*

<b>NS0</b>	no interior option <input type="checkbox"/>	+\$0
<b>NS1</b>	1 shelf total <input type="checkbox"/>	+\$39
<b>NS2</b>	2 shelves total <input type="checkbox"/>	+\$78
<b>NS3</b>	3 shelves total <input type="checkbox"/>	+\$117
<b>NS4</b>	4 shelves total <input type="checkbox"/>	+\$156
<b>NS5</b>	5 shelves total <input type="checkbox"/>	+\$195
<b>9L</b>	center bar for computer printout binders <input type="checkbox"/>	+\$58
<b>WC</b>	coat rod with shelf <input type="checkbox"/>	+\$89
<b>W</b>	coat rod with 3 shelves (only available with T2 top) <input type="checkbox"/>	+\$197

Step 8. Lock

<b>KA</b>	keyed alike <input type="checkbox"/>	+\$0
<b>KC</b>	keyed differently, chrome <input type="checkbox"/>	+\$0
<b>KD</b>	keyed differently, black <input type="checkbox"/>	+\$0

Step 9. Top

<b>NT</b>	no top <input type="checkbox"/>	+\$0
<b>T1</b>	1"-high painted metal top with squared edge <input type="checkbox"/>	+\$0
<b>T2</b>	1 <sup>1</sup> / <sub>4</sub> "-high painted metal top with squared edge <input type="checkbox"/>	+\$0
<b>T6</b>	1 <sup>1</sup> / <sub>32</sub> " security top <input type="checkbox"/>	+\$0
<b>T3</b>	1 <sup>1</sup> / <sub>4</sub> "-high painted metal top with radius edge <input type="checkbox"/>	+\$55
<b>TL</b>	1 <sup>1</sup> / <sub>4</sub> "-high laminate top with vinyl edge <input type="checkbox"/>	+\$63
<b>T4</b>	1 <sup>1</sup> / <sub>4</sub> "-high laminate top with squared edge <input type="checkbox"/>	+\$120
<b>TR</b>	1 <sup>1</sup> / <sub>4</sub> "-high recut veneer top <input type="checkbox"/>	+\$132
<b>J3</b>	1 <sup>1</sup> / <sub>4</sub> "-high cathedral recut veneer top <input type="checkbox"/>	+\$135
<b>TF</b>	1 <sup>1</sup> / <sub>4</sub> "-high wood veneer top <input type="checkbox"/>	+\$137
<b>T7</b>	6 <sup>1</sup> / <sub>2</sub> "-high planter top <input type="checkbox"/>	+\$177
<b>T5</b>	1 <sup>1</sup> / <sub>4</sub> "-high laminate top with radius edge <input type="checkbox"/>	+\$242
<b>D1</b>	6 <sup>1</sup> / <sub>2</sub> "-high full dome, side-to-side <input type="checkbox"/>	+\$242
<b>D3</b>	4 <sup>1</sup> / <sub>2</sub> "-high full dome, side-to-side <input type="checkbox"/>	+\$242
<b>H1</b>	6 <sup>1</sup> / <sub>2</sub> "-high half dome, sloping left <input type="checkbox"/>	+\$242
<b>H2</b>	6 <sup>1</sup> / <sub>2</sub> "-high half dome, sloping right <input type="checkbox"/>	+\$242
<b>H5</b>	4 <sup>1</sup> / <sub>2</sub> "-high half dome, sloping left <input type="checkbox"/>	+\$242
<b>H6</b>	4 <sup>1</sup> / <sub>2</sub> "-high half dome, sloping right <input type="checkbox"/>	+\$242
<b>TV1</b>	1 <sup>1</sup> / <sub>8</sub> "-high wood veneer top and wood composite edge with oversail front <input type="checkbox"/>	+\$284
<b>TC1</b>	1" cushion top <input type="checkbox"/>	+\$350
<b>TC2</b>	2" cushion top <input type="checkbox"/>	+\$350

Step 10.

Top Finish: Solid-Color Laminate

*For 1<sup>1</sup>/<sub>4</sub>"-high laminate top with vinyl edge (TL)*

<b>8Q</b>	folkstone grey <input type="checkbox"/>	+\$0
<b>91</b>	white <input type="checkbox"/>	+\$0
<b>CL</b>	cool grey neutral <input type="checkbox"/>	+\$0
<b>HF</b>	inner tone light <input type="checkbox"/>	+\$0
<b>HT</b>	inner tone <input type="checkbox"/>	+\$0
<b>LT</b>	light tone <input type="checkbox"/>	+\$0
<b>LU</b>	soft white <input type="checkbox"/>	+\$0
<b>WL</b>	sandstone <input type="checkbox"/>	+\$0
<b>WN</b>	warm grey neutral <input type="checkbox"/>	+\$0

Top Finish: Fiber Laminate

*For 1<sup>1</sup>/<sub>4</sub>"-high laminate top with vinyl edge (TL)*

<b>1X</b>	vanilla <input type="checkbox"/>	+\$0
<b>2X</b>	wheat <input type="checkbox"/>	+\$0
<b>3X</b>	celery <input type="checkbox"/>	+\$0
<b>4X</b>	coriander <input type="checkbox"/>	+\$0
<b>5X</b>	chamomile <input type="checkbox"/>	+\$0
<b>6X</b>	cinnamon <input type="checkbox"/>	+\$0
<b>7X</b>	cardamom <input type="checkbox"/>	+\$0
<b>8X</b>	kale <input type="checkbox"/>	+\$0

Top Finish: Frosted Laminate

*For 1<sup>1</sup>/<sub>4</sub>"-high laminate top with vinyl edge (TL)*

<b>J4</b>	frosted light grey <input type="checkbox"/>	+\$0
<b>J5</b>	frosted inner tone light <input type="checkbox"/>	+\$0
<b>J6</b>	frosted slate grey <input type="checkbox"/>	+\$0
<b>J7</b>	frosted medium tone <input type="checkbox"/>	+\$0
<b>J8</b>	frosted black <input type="checkbox"/>	+\$0

Top Finish: Wood-Grain Laminate

*For 1<sup>1</sup>/<sub>4</sub>"-high laminate top with vinyl edge (TL)*

<b>LA</b>	light ash <input type="checkbox"/>	+\$0
<b>LM</b>	mahogany <input type="checkbox"/>	+\$0

Top Finish: Zephyr Laminate

*For 1<sup>1</sup>/<sub>4</sub>"-high laminate top with vinyl edge (TL)*

<b>D1</b>	canyon <input type="checkbox"/>	+\$0
<b>DC</b>	misted <input type="checkbox"/>	+\$0
<b>DF</b>	twilight <input type="checkbox"/>	+\$0
<b>DQ</b>	desert <input type="checkbox"/>	+\$0

Ellipse-Pull Storage Case *continued*

Top/Edge Finish: Solid-Color Laminate

For 1 1/4"-high laminate top with squared edge (T4) or 1 1/4"-high laminate top with radius edge (T5)

<b>8Q</b>	folkstone grey <input type="checkbox"/>	+\$0
<b>91</b>	white <input type="checkbox"/>	+\$0
<b>CL</b>	cool grey neutral <input type="checkbox"/>	+\$0
<b>HF</b>	inner tone light <input type="checkbox"/>	+\$0
<b>HT</b>	inner tone <input type="checkbox"/>	+\$0
<b>LT</b>	light tone <input type="checkbox"/>	+\$0
<b>LU</b>	soft white <input type="checkbox"/>	+\$0
<b>WL</b>	sandstone <input type="checkbox"/>	+\$0
<b>WN</b>	warm grey neutral <input type="checkbox"/>	+\$0

Top/Edge Finish: Fiber Laminate

For 1 1/4"-high laminate top with squared edge (T4) or 1 1/4"-high laminate top with radius edge (T5)

<b>1X</b>	vanilla <input type="checkbox"/>	+\$0
<b>2X</b>	wheat <input type="checkbox"/>	+\$0
<b>3X</b>	celery <input type="checkbox"/>	+\$0
<b>4X</b>	coriander <input type="checkbox"/>	+\$0
<b>5X</b>	chamomile <input type="checkbox"/>	+\$0
<b>6X</b>	cinnamon <input type="checkbox"/>	+\$0
<b>7X</b>	cardamom <input type="checkbox"/>	+\$0
<b>8X</b>	kale <input type="checkbox"/>	+\$0

Top/Edge Finish: Frosted Laminate

For 1 1/4"-high laminate top with squared edge (T4) or 1 1/4"-high laminate top with radius edge (T5)

<b>J4</b>	frosted light grey <input type="checkbox"/>	+\$0
<b>J5</b>	frosted inner tone light <input type="checkbox"/>	+\$0
<b>J6</b>	frosted slate grey <input type="checkbox"/>	+\$0
<b>J7</b>	frosted medium tone <input type="checkbox"/>	+\$0
<b>J8</b>	frosted black <input type="checkbox"/>	+\$0

Top/Edge Finish: Wood-Grain Laminate

For 1 1/4"-high laminate top with squared edge (T4) or 1 1/4"-high laminate top with radius edge (T5)

<b>LA</b>	light ash <input type="checkbox"/>	+\$0
<b>LM</b>	mahogany <input type="checkbox"/>	+\$0

Top/Edge Finish: Zephyr Laminate

For 1 1/4"-high laminate top with squared edge (T4) or 1 1/4"-high laminate top with radius edge (T5)

<b>D1</b>	canyon <input type="checkbox"/>	+\$0
<b>DC</b>	misted <input type="checkbox"/>	+\$0
<b>DF</b>	twilight <input type="checkbox"/>	+\$0
<b>DQ</b>	desert <input type="checkbox"/>	+\$0

Veneer Top Finish: Recut Veneer

For 1 1/4"-high recut veneer top (TR)

<b>RA</b>	light ash <input type="checkbox"/>	+\$0
<b>RK</b>	mahogany dark <input type="checkbox"/>	+\$0
<b>RM</b>	mahogany <input type="checkbox"/>	+\$0

Veneer Top Finish: Recut Veneer

For 1 1/4"-high cathedral recut veneer top (J3)

<b>DU</b>	cathedral recut natural maple <input type="checkbox"/>	+\$0
<b>HU</b>	cathedral recut light anigre <input type="checkbox"/>	+\$0
<b>JU</b>	cathedral recut aged cherry <input type="checkbox"/>	+\$0
<b>VU</b>	cathedral recut light brown walnut <input type="checkbox"/>	+\$0
<b>WU</b>	cathedral recut walnut on cherry <input type="checkbox"/>	+\$0
<b>XU</b>	cathedral recut medium red cherry <input type="checkbox"/>	+\$0
<b>ZU</b>	cathedral recut chocolate brown sapele <input type="checkbox"/>	+\$0

Veneer Top Finish: Wood Veneer

For 1 1/4"-high wood veneer top (TF)

<b>V3</b>	cherry <input type="checkbox"/>	+\$21
<b>Z3</b>	warm red cherry <input type="checkbox"/>	+\$21
<b>Z5</b>	maple <input type="checkbox"/>	+\$21
<b>2U</b>	light brown walnut <input type="checkbox"/>	+\$28
<b>3U</b>	medium red cherry <input type="checkbox"/>	+\$28
<b>6U</b>	chocolate brown sapele <input type="checkbox"/>	+\$28
<b>ED</b>	aged cherry <input type="checkbox"/>	+\$28
<b>EG</b>	medium brown walnut <input type="checkbox"/>	+\$28
<b>EK</b>	medium red walnut <input type="checkbox"/>	+\$28
<b>EY</b>	light anigre <input type="checkbox"/>	+\$28
<b>UL</b>	natural maple <input type="checkbox"/>	+\$28
<b>UQ</b>	light cherry <input type="checkbox"/>	+\$28
<b>UV</b>	red cherry <input type="checkbox"/>	+\$28
<b>UX</b>	walnut on cherry <input type="checkbox"/>	+\$28

Veneer Top Finish: Wood Veneer

For 1 1/8"-high wood veneer top and wood composite edge with oversail front (TV1)

<b>ED</b>	aged cherry <input type="checkbox"/>	+\$28
<b>EG</b>	medium brown walnut <input type="checkbox"/>	+\$28
<b>EK</b>	medium red walnut <input type="checkbox"/>	+\$28
<b>EY</b>	light anigre <input type="checkbox"/>	+\$28
<b>UL</b>	natural maple <input type="checkbox"/>	+\$28
<b>UQ</b>	light cherry <input type="checkbox"/>	+\$28
<b>UV</b>	red cherry <input type="checkbox"/>	+\$28
<b>UX</b>	walnut on cherry <input type="checkbox"/>	+\$28

My Studio Environments™ Storage

**Step 11. Edge Finish**

*For 1 1/4"-high laminate top with vinyl edge (TL)*

<b>8Q</b>	folkstone grey <input type="checkbox"/> A	+\$0
<b>91</b>	white <input type="checkbox"/> A	+\$0
<b>BU</b>	black umber <input type="checkbox"/> A	+\$0
<b>CL</b>	cool grey neutral <input type="checkbox"/> A	+\$0
<b>CM</b>	cinnamon <input type="checkbox"/> A	+\$0
<b>CO</b>	chamomile <input type="checkbox"/> A	+\$0
<b>G2</b>	graphite satin <input type="checkbox"/> A	+\$0
<b>HF</b>	inner tone light <input type="checkbox"/> A	+\$0
<b>HT</b>	inner tone <input type="checkbox"/> A	+\$0
<b>LA</b>	light ash <input type="checkbox"/> A	+\$0
<b>LM</b>	mahogany <input type="checkbox"/> A	+\$0
<b>LU</b>	soft white <input type="checkbox"/> A	+\$0
<b>MT</b>	medium tone <input type="checkbox"/> A	+\$0
<b>SG</b>	slate grey <input type="checkbox"/> A	+\$0
<b>WL</b>	sandstone <input type="checkbox"/> A	+\$0
<b>WN</b>	warm grey neutral <input type="checkbox"/> A	+\$0

**Step 12. Cushion Top Fabric**

*For 1" cushion top (TC1) or 2" cushion top (TC2)*

*See textiles list for fabric numbers. First 2 digits of number indicate fabric line; remaining digit(s) indicate fabric color.*

Price Category 1	+\$0
Price Category 2	+\$55
Price Category 3	+\$67
Price Category 4	+\$82
Price Category 7	+\$137
Price Category 9	+\$950
Price Category B	+\$56
Price Category E	+\$139
Price Category G	+\$250
Price Category H	+\$333

**Step 13. Base Height**

*For 23 1/2" high (26), 26 1/4" high (29), 35 1/4" high (38), or 39 3/8" high (42)*

<b>B1</b>	1"-high base <input type="checkbox"/> A	+\$0
<b>B2</b>	1 1/2"-high base <input type="checkbox"/> A	+\$0
<b>B3</b>	2 1/4"-high base <input type="checkbox"/> A	+\$0
<b>B4</b>	3 1/4"-high base <input type="checkbox"/> A	+\$0
<b>BA</b>	1"-high recessed base <input type="checkbox"/> A	+\$32
<b>BB</b>	1 1/2"-high recessed base <input type="checkbox"/> A	+\$32
<b>BC</b>	2 1/4"-high recessed base <input type="checkbox"/> A	+\$32
<b>BD</b>	3 1/4"-high recessed base <input type="checkbox"/> A	+\$32
<b>B5</b>	4 1/4"-high base <input type="checkbox"/> A	+\$32
<b>B9</b>	4 3/4"-high mobile base <input type="checkbox"/> A	+\$270

*For 47" high (50), 52 1/2" high (55), 60 1/8" high (63), 62 7/8" high (66), or 65 5/8" high (69)*

<b>B1</b>	1"-high base <input type="checkbox"/> A	+\$0
<b>B2</b>	1 1/2"-high base <input type="checkbox"/> A	+\$0
<b>B3</b>	2 1/4"-high base <input type="checkbox"/> A	+\$0
<b>B4</b>	3 1/4"-high base <input type="checkbox"/> A	+\$0
<b>BA</b>	1"-high recessed base <input type="checkbox"/> A	+\$32
<b>BB</b>	1 1/2"-high recessed base <input type="checkbox"/> A	+\$32
<b>BC</b>	2 1/4"-high recessed base <input type="checkbox"/> A	+\$32
<b>BD</b>	3 1/4"-high recessed base <input type="checkbox"/> A	+\$32
<b>B5</b>	4 1/4"-high base <input type="checkbox"/> A	+\$32

# Index by Product Name

<b>My Studio Environments™</b>	
	page(s)
Bookcase	66
Bookcase Back Panel	69
Bookcase Horizontal Divider	72
Bookshelf	70
Ceiling Power Entry	25
Center Wall Aisle Cladding	34
Center Wall Attachment Hardware	7
Center Wall Cable Manager	28
Center Wall Display Zone Cladding	36
Center Wall Finished End	9
Center Wall Frame	5
Center Wall Lower Cladding	31
Center Wall Power/Data Cladding	32
Center Wall Transom	8
Closet	75
Closet Shelf	76
Coat Hook	77
Concave Primary Surface	48
Door	18
Easel	63
Ellipse-Pull Freestanding Lateral File	78
Ellipse-Pull Freestanding Pedestal	84
Ellipse-Pull Mobile Pedestal	89
Ellipse-Pull Storage Case	94
Floor Power Entry, New York City	24
Header	17
Inside Ledge	10
Message Board	64
Name Plate	65
Outside Ledge	11
Power Entry, Internal Direct Connect	23
Power Harness	20
Power/Data Distributor	21
Primary Surface Support	52
Receptacle, 15 Amp	26
Receptacle, 20 Amp	27
Rectangular Secondary Surface	56
Rolling Tool Rail	73
Round-End Secondary Surface	58
Secondary Surface End Support	62
Secondary Surface Support	60
Seismic Anchor Kit	14
Side Wall Cladding	38
Side Wall Frame	12
Side Wall Shutter	40

Streetside Curved Frame	15
Streetside Curved Lower Cladding	41
Streetside Curved Monolithic Cladding	46
Streetside Curved Upper Cladding	42
Streetside Straight Frame	16
Streetside Straight Lower Cladding	44
Streetside Straight Monolithic Cladding	47
Streetside Straight Upper Cladding	45
Support Leg	53, 61
Surface-Attached Receptacle	30
Surface Cable Management Kit	29
Surface Trough	22
Tool Rail	74
Transom Shutter	37
Wall Start, Side Wall	13
Winged-End Primary Surface	50
Winged-End Secondary Surface	54



# Index by Product Number

2J-30	Ellipse-Pull Freestanding Lateral File	page(s) 78	NT178. Center Wall Cable Manager	28
2J-36			NT179. Surface Cable Management Kit	29
2J-42			NT180. Surface-Attached Receptacle	30
4J-30	Ellipse-Pull Storage Case	94	NT220. Concave Primary Surface	48
4J-36			NT221. Winged-End Primary Surface	50
4J-42			NT290. Primary Surface Support	52
F1J-1	Ellipse-Pull Freestanding Pedestal	84	NT291. Support Leg	53, 61
M1J-1	Ellipse-Pull Mobile Pedestal	89	NT310. Winged-End Secondary Surface	54
MJ420.	Bookcase	66	NT311. Rectangular Secondary Surface	56
MJ421.	Bookshelf	70	NT312. Round-End Secondary Surface	58
MJ422.	Bookcase Horizontal Divider	72	NT390. Secondary Surface Support	60
MJ423.	Bookcase Back Panel	69	NT391. Secondary Surface End Support	62
NT110.	Center Wall Frame	5	NT412. Rolling Tool Rail	73
NT111.	Center Wall Attachment Hardware	7	NT413. Tool Rail	74
NT112.	Center Wall Transom	8	NT425. Closet	75
NT115.	Center Wall Finished End	9	NT426. Closet Shelf	76
NT117.	Inside Ledge	10	NT430. Easel	63
NT118.	Outside Ledge	11	NT431. Message Board	64
NT119.	Seismic Anchor Kit	14	NT433. Coat Hook	77
NT120.	Side Wall Frame	12	NT434. Name Plate	65
NT124.	Wall Start, Side Wall	13		
NT130.	Streetside Curved Frame	15		
NT131.	Streetside Straight Frame	16		
NT133.	Door	18		
NT134.	Header	17		
NT140.	Center Wall Lower Cladding	31		
NT141.	Center Wall Power/Data Cladding	32		
NT142.	Center Wall Aisle Cladding	34		
NT143.	Center Wall Display Zone Cladding	36		
NT144.	Transom Shutter	37		
NT150.	Side Wall Cladding	38		
NT152.	Side Wall Shutter	40		
NT160.	Streetside Curved Lower Cladding	41		
NT161.	Streetside Curved Upper Cladding	42		
NT162.	Streetside Straight Lower Cladding	44		
NT163.	Streetside Straight Upper Cladding	45		
NT164.	Streetside Curved Monolithic Cladding	46		
NT165.	Streetside Straight Monolithic Cladding	47		
NT170.	Power Harness	20		
NT171.	Power/Data Distributor	21		
NT172.	Surface Trough	22		
NT173.	Power Entry, Internal Direct Connect	23		
NT174.	Floor Power Entry, New York City	24		
NT175.	Ceiling Power Entry	25		
NT176.	Receptacle, 15 Amp	26		
NT177.	Receptacle, 20 Amp	27		

For more information about our products and services or to see a list of dealers, please visit us at [www.HermanMiller.com](http://www.HermanMiller.com) or call (800) 851 1196.

This book is recyclable. Printed in U.S.A. on recycled paper.

© 2009 Herman Miller, Inc., Zeeland, Michigan

© HermanMiller, , Abak, Action Office, Aeron, Ambi, Ardea, Aside, Avive, Babble, C2, Caper, Celle, Co/Struc, DOT, Eames, Embody, Equa 2, Ergon 3, Ethospace, Fine-Tune, FlexFront, Formcoat, Ground Cloth, Herman Miller for Healthcare, Herman Miller Options, Intersect, Kinemat, Leaf, Lifework, Limerick, Meridian, Mirra, Passage, Pedastool, Pellicle, Perspectives, PostureFit, Prospects, Quadrant, Reaction, Resolve, RoomTune, Scooter, Stoa, Teneo, V-Wall, Vary Easy, Vivo, and Z-Axis are among the registered trademarks of Herman Miller, Inc., and its owned subsidiaries.

™ About Face, AireWeave, Airia, Arrio, Backfit, Boomerang, Bubbletack, Burdick Group, Celeste, Cellular Suspension, CLT, CoActive, Cognita, Compass, Cygnus, Enchord, EnhancedAccess, E-Wall, Flex-Edge, Flute, Harmonic, Herman Miller for the Home, Herman Miller International Collection, Herman Miller Select, Hopsak 2, Intent, Iota, Keyless Entry, Latitude, Lyris, Multiscrim, My Studio Environments, Nelson, Pixelated Support, Programmable Environments, Q, Rapunzel, Recline Selector, Sense, Setu, Stackable, Stackable Storage, The Be Collection, Thinking is good for you, TriFlex, Tu, and Twist are among the trademarks of Herman Miller, Inc., and its owned subsidiaries.

SM TAP, Textile Alliance Program and Thoughtpile are among the service marks of Herman Miller, Inc.

Chemsurf is a registered trademark of Wilsonart International.

Corian is a registered trademark of DuPont.

FLEXNET is a trademark of Milliken & Co.

Floor Saver Glide™ is a trademark of Carpin Manufacturing Inc.

Geiger is a registered trademark of Geiger International.

Goetz is a trademark of Mark W. Goetz.

Hang-It-All is a registered trademark of Lucia Eames Demetrios, d.b.a. Eames Office.

Holophane is a registered trademark of Holophane.

Ingeo is a trademark of Cargill Dow LLC.

Microsoft and Natural Keyboard are registered trademarks of Microsoft Corporation.

Noguchi® is a registered trademark of The Isamu Noguchi Foundation and Garden Museum.

Qt Quiet technology and Qt are trademarks of Cambridge Sound Management, Inc.