



Prices effective January 6, 2020

Published March 2020

# Canvas Office Landscape® Vista™

<b>Introduction</b>	<b>page 2</b>
<b>Canvas Office Landscape Vista</b>	<b>3</b>
Infrastructure	5
Energy Distribution	15
Cable Management	39
Work Surfaces	43
Screens	65
Accessories	103
Height Adjustable Table	111
Storage-Tu® Wood for Vista	129
<b>Indices</b>	<b>183</b>
By Name	183
By Number	185
<b>Appendices</b>	
20-Day or Less/Assigned Lead-Time Order Information	
Keyed-Alike Information	
Vary Easy Program	
Proprietary Textiles Application Chart-Workspaces	
Proprietary Textile Colors-Workspaces	
<b>For the latest materials information, refer to the Materials pages on HermanMiller.com.</b>	

# Introduction

## A Note on the Organization of This Book

There are a few signals that will help you understand the organization of this book. Once you know them, you should be able to find your way around easily.

## Like a newspaper, this book is formatted with columns of text and illustrations that run vertically.

Information wraps from one column to the next and continues for as many pages as it needs to.

## Black bars are clues.

A black bar at the top of a page signals the start of information about a product.

This information is divided into two sections, each signaled by a black bar. Product Information includes a description, additional notes, and dimensional drawings. Specification Information, which always begins at the top of a column, includes a series of steps. Each step represents a decision you need to make in order to complete your product number. Steps must be followed sequentially. The number of pages needed to complete information on a product varies; some will be complete in one page; others may fill three or four pages. Just continue going through the steps until you run into the next product, signaled by the black bar at the top of the page.

Black tabs running along the outside edge of the page help you locate what section you are in or what section you want to go to. You can thumb forwards or backwards to find a section; tabs and text appear on both sides of the page.

The additional pages in the back of the book include the appendices and indices. They are signaled by a long black bar running along the outside edge of the page.

## The index is presented two ways.

The first index is in alphabetical order by product name. It can be helpful if you are new to the products and numbering scheme or if you are looking for a type of product, such as work chair or round table.

The second index is by product number. It lists, in alphanumeric order, the base product number, typically a five-digit number.

This book is effective January 6, 2020, subject to change without notice. Products may be purchased from authorized Herman Miller dealers who will quote prices upon request. For more information about our products and services or to see a list of dealers, visit [www.HermanMiller.com](http://www.HermanMiller.com).

All prices are list prices in US Dollars. Additional services, such as planning services, design, storage, and installation, are not included and must be added to these prices when the additional services are requested.

Illustrations, specifications, and prices are based on the latest information at the time of publication. The right is reserved to make changes at any time without notice in prices, fabrics, finishes, materials, specifications, and models, and also to discontinue models and finishes.

Dimensions shown in the drawings are engineering drawing dimensions rounded up to the nearest  $\frac{1}{8}$ ". Product is shipped set up or knocked down. Products that include "Shipped knocked down" in the description require some assembly. If this statement does not appear in the description, the product is shipped assembled.

Service problems are normally handled by a Herman Miller authorized dealer. Where this cannot be accomplished on a local level, service problems should be referred to the Customer Care Representative for your region, Herman Miller, Inc., Zeeland, Michigan 49464.

## 20-Day or Less/Assigned Lead-Time Shipments

All products and options in this price book not designated by an Assigned Program icon  will ship in **20 business days or less** after being acknowledged by Herman Miller.

Products and options designated by an  are on the assigned lead-time program and may ship in 20 days, less than 20 days, or more than 20 days from order acknowledgement.

<b>Infrastructure</b>	
<b>Energy Distribution</b>	
<b>Cable Management</b>	
<b>Work Surfaces</b>	
<b>Screens</b>	
<b>Accessories</b>	
<b>Height Adjustable Table</b>	
<b>Storage - Tu Wood for Canvas Vista™</b>	



# Chase

FG110.

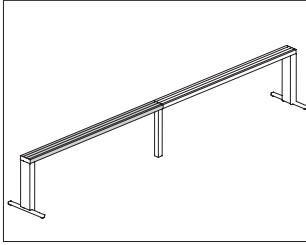

### Product Information

#### Description

This aluminum extrusion distributes power, data and cable management to the user. The chase has 3 tracks on top that are designed for flexibility and to layer work surfaces, screens, T-lights, Ubi work tools and other accessories. The chase has 2 tracks on the bottom for attaching legs, wire management, Ubi work tools and power + data covers. Plastic covers are included to cover power and data cables in the bottom of chase.

#### Notes

Chase is 6" deep.

Overall chase height above finished floor is 26 1/2".

Power can enter chase at end of run or at an intermediate location using floor power entry (FG144.) or ceiling power entry (FG142.). For New York City floor power entry, order floor power entry (FG141.) separately.

Chase must be supported by structural and nonstructural supports depending on length of run and application. See planning guide for additional planning information.

Order the following products separately:

- Structural chase A-leg (FG11A.)
- Structural chase T-leg (FG119.)
- Non-structural chase post leg (FG117.)
- End cap (FG160.)

#### Dimensions

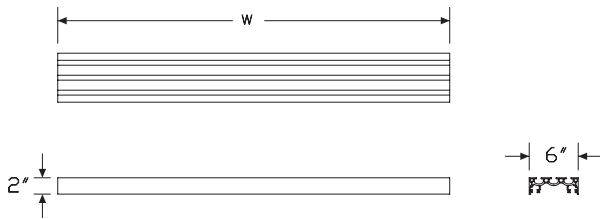

### Specification Information

#### Step 1.

**FG110.**

#### Step 2. Width

<b>48</b>	48" wide
<b>60</b>	60" wide
<b>66</b>	66" wide
<b>72</b>	72" wide
<b>84</b>	84" wide
<b>96</b>	96" wide

#### Prices for Steps 1-2.

<b>FG110. 48</b>	\$515
<b>60</b>	\$610
<b>66</b>	\$668
<b>72</b>	\$726
<b>84</b>	\$915
<b>96</b>	\$1105

#### Step 3. Finish

##### Smooth Paint

<b>8Q</b>	folkstone grey	+\$0
<b>91</b>	white	+\$0
<b>98</b>	studio white	+\$0
<b>CL</b>	cool grey neutral	+\$0
<b>WL</b>	sandstone	+\$0
<b>WN</b>	warm grey neutral	+\$0

##### Metallic Paint

<b>CN</b>	metallic champagne	+\$0
<b>EH</b>	metallic bronze	+\$0
<b>MS</b>	metallic silver	+\$0

##### Sand Texture Paint

<b>BK</b>	black	+\$0
<b>G1</b>	graphite	+\$0

# Chase End Cap

FG160.

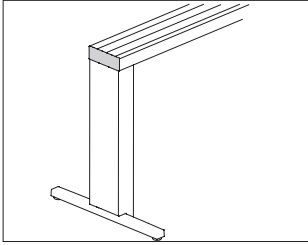

Canvas Vista™ Infrastructure

### Product Information

**Description**  
This end trim finishes the exposed ends of the Vista™ chase. Quantity of 2.

**Notes**  
Specify 1 set of end caps for a single chase. For a run of 2 or more chases, specify 1 set of end caps.

### Dimensions

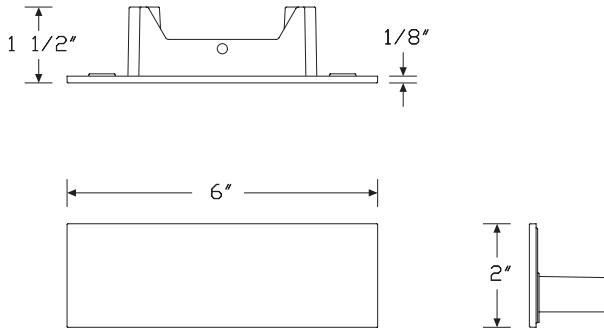

### Specification Information

**Step 1.**  
**FG160.** \$87

### Step 2. Finish

**Smooth Paint**

<b>8Q</b>	folkstone grey	+\$0
<b>91</b>	white	+\$0
<b>98</b>	studio white	+\$0
<b>CL</b>	cool grey neutral	+\$0
<b>WL</b>	sandstone	+\$0
<b>WN</b>	warm grey neutral	+\$0

**Metallic Paint**

<b>CN</b>	metallic champagne	+\$0
<b>EH</b>	metallic bronze	+\$0
<b>MS</b>	metallic silver	+\$0

**Sand Texture Paint**

<b>BK</b>	black	+\$0
<b>G1</b>	graphite	+\$0

# Structural Chase A-Leg

FG11A.

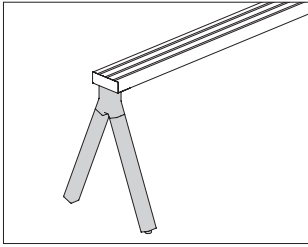

### Product Information

#### Description

This structural A-leg provides support on one end of the chase. This fixed height leg provides 2" of leveling adjustment. Attachment hardware included.

#### Notes

2 end legs, 1 at each end of the chase, are needed to provide support. For length of run and proper support information, see planning guide.

#### Dimensions

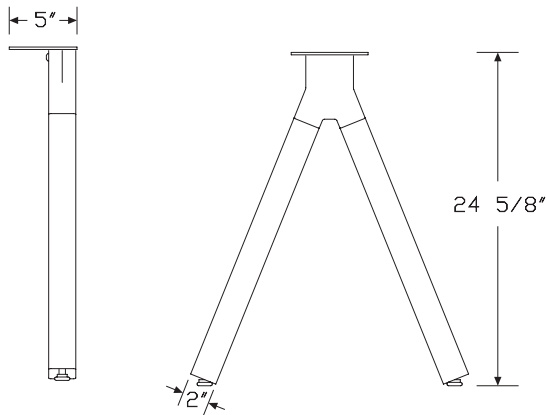
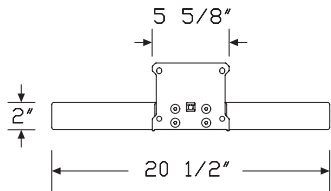

### Specification Information

#### Step 1.

**FG11A.** \$705

#### Step 2. Leg Finish

#### Smooth Paint

<b>8Q</b>	folkstone grey	+\$0
<b>91</b>	white	+\$0
<b>98</b>	studio white	+\$0
<b>CL</b>	cool grey neutral	+\$0
<b>WL</b>	sandstone	+\$0
<b>WN</b>	warm grey neutral	+\$0

#### Metallic Paint

<b>CN</b>	metallic champagne	+\$0
<b>EH</b>	metallic bronze	+\$0
<b>MS</b>	metallic silver	+\$0

#### Sand Texture Paint

<b>BK</b>	black	+\$0
<b>G1</b>	graphite	+\$0

# Structural Chase T-Leg

FG119.

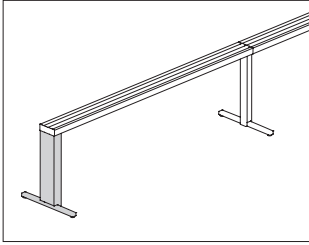

Canvas Vista™ Infrastructure

## Product Information

### Description

This structural T-leg provides support on one end of the chase or at an intermediate location. This fixed height leg provides 2" of leveling adjustment. Attachment hardware included.

### Notes

2 end legs, 1 at each end of the chase, are required to provide support. Structural T-leg, end (FG119.1A) is used on the end of the chase. Structural T-leg, intermediate (FG119.1B) is used where 2 chase sections come together in the intermediate location or along the chase where additional support is needed. For length of run and proper support information, see planning guide.

## Dimensions

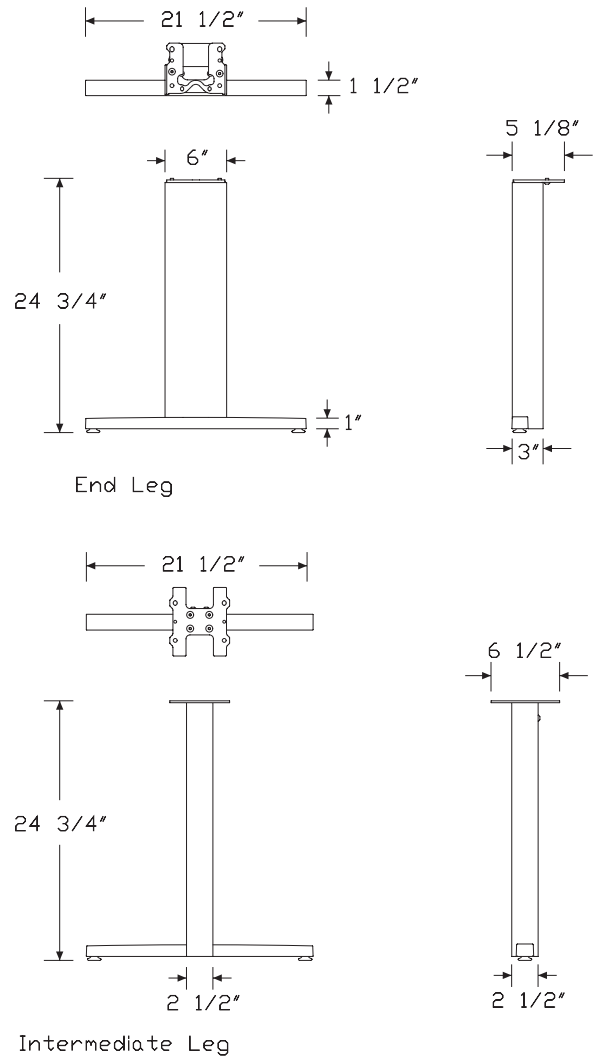

**Specification Information**

Step 1.

**FG119.**

Step 2. Leg Location

**1A** end

**1B** intermediate

Prices for Steps 1-2.

<b>FG119. 1A</b>	\$456
<b>1B</b>	\$373

Step 3. Leg Finish

Smooth Paint

<b>8Q</b>	folkstone grey	+ \$0
<b>91</b>	white	+ \$0
<b>98</b>	studio white	+ \$0
<b>CL</b>	cool grey neutral	+ \$0
<b>WL</b>	sandstone	+ \$0
<b>WN</b>	warm grey neutral	+ \$0

Metallic Paint

<b>CN</b>	metallic champagne	+ \$0
<b>EH</b>	metallic bronze	+ \$0
<b>MS</b>	metallic silver	+ \$0

Sand Texture Paint

<b>BK</b>	black	+ \$0
<b>G1</b>	graphite	+ \$0

# Non-Structural Chase Post Leg

FG117.

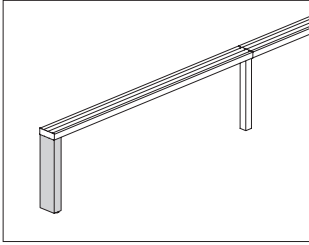

Canvas Vista™ Infrastructure

## Product Information

### Description

This nonstructural post leg provides support on one end of the chase or at an intermediate location. This fixed height leg provides 2" of leveling adjustment. Attachment hardware included.

### Notes

2 end legs, 1 at each end of the chase, are required to provide support. Nonstructural post leg, end (FG117.1A) is used on the end of the chase. Nonstructural post leg, intermediate (FG117.1B) is used where 2 chase sections come together in the intermediate location or along the chase where additional support is needed. For length of run and proper support information, see planning guide.

## Dimensions

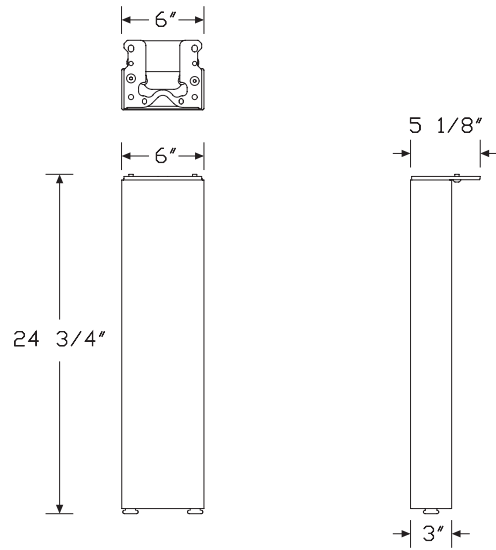

Post End Leg

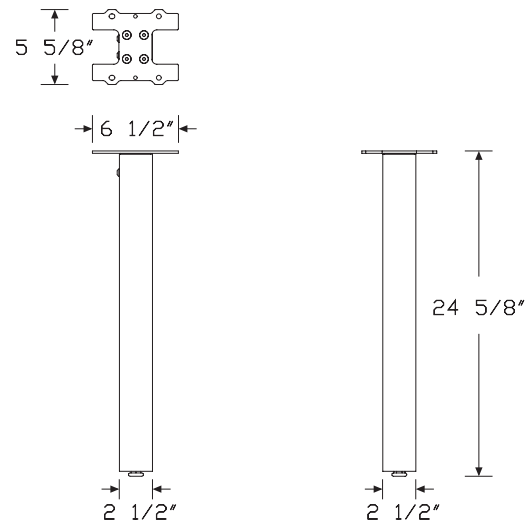

Intermediate Leg

# Non-Structural Chase Post Leg

continued

## Specification Information

Step 1.

**FG117.**

Step 2. Leg Location

**1A** end

**1B** intermediate

Prices for Steps 1-2.

<b>FG117. 1A</b>	\$383
<b>1B</b>	\$300

Step 3. Leg Finish

Smooth Paint

<b>8Q</b> folkstone grey	+\$0
<b>91</b> white	+\$0
<b>98</b> studio white	+\$0
<b>CL</b> cool grey neutral	+\$0
<b>WL</b> sandstone	+\$0
<b>WN</b> warm grey neutral	+\$0

Metallic Paint

<b>CN</b> metallic champagne	+\$0
<b>EH</b> metallic bronze	+\$0
<b>MS</b> metallic silver	+\$0

Sand Texture Paint

<b>BK</b> black	+\$0
<b>G1</b> graphite	+\$0

Structural Support, Low Storage  
to Chase

FG292.

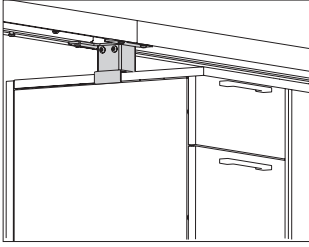

Canvas Vista™ Infrastructure

**Product Information**

**Description**

This structural storage support provides support to the chase by attaching to the top surface of a Tu® Wood for Vista™ shared or individual credenza. Attachment hardware included.

**Notes**

For use with a Tu Wood for Vista shared storage credenza, specify clamp mount (1A).

Clamp mount (1A) slides into place without defacing credenza top.

For use with a Tu Wood for Vista individual storage credenza, specify through mount (1B).

Through mount (1B) will deface the storage surface top by drilling into it.

Through mount (1B) can also be used with Tu storage units that have an overall height of 22".

For length of run and proper support information, see planning guide.

**Dimensions**

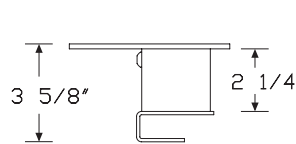
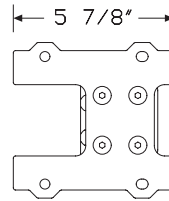

Clamp Mount

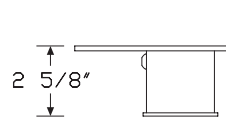
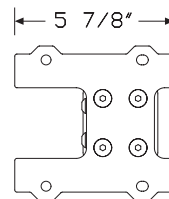
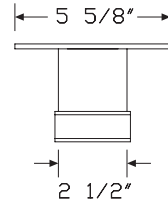

Through Mount

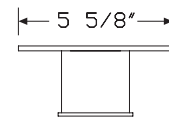

# Structural Support, Low Storage to Chase *continued*

## Specification Information

Step 1.

**FG292.**

Step 2. Application

- 1A** clamp mount, for use with Vista shared storage
- 1B** through mount, for use with single sided storage

Prices for Steps 1-2.

<b>FG292. 1A</b>	\$373
<b>1B</b>	\$373

Step 3. Leg Finish

Smooth Paint

<b>8Q</b>	folkstone grey	+ \$0
<b>91</b>	white	+ \$0
<b>98</b>	studio white	+ \$0
<b>CL</b>	cool grey neutral	+ \$0
<b>WL</b>	sandstone	+ \$0
<b>WN</b>	warm grey neutral	+ \$0

Metallic Paint

<b>CN</b>	metallic champagne	+ \$0
<b>EH</b>	metallic bronze	+ \$0
<b>MS</b>	metallic silver	+ \$0

Sand Texture Paint

<b>BK</b>	black	+ \$0
<b>G1</b>	graphite	+ \$0

Chase Connector Kit

FG121.

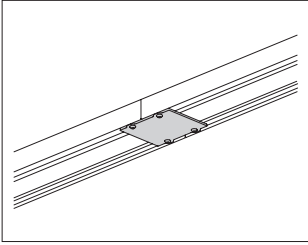

Canvas Vista™ Infrastructure

**Product Information**

**Description**

This connector kit is used to connect one chase to another when a structural or nonstructural support is not used at the chase-to-chase intersection. Finish is black. Attachment hardware is included.

**Notes**

When using a chase connector kit, a structural or nonstructural support is needed within 1' of the connection. Order support separately. For proper support information, see planning guide.

**Dimensions**

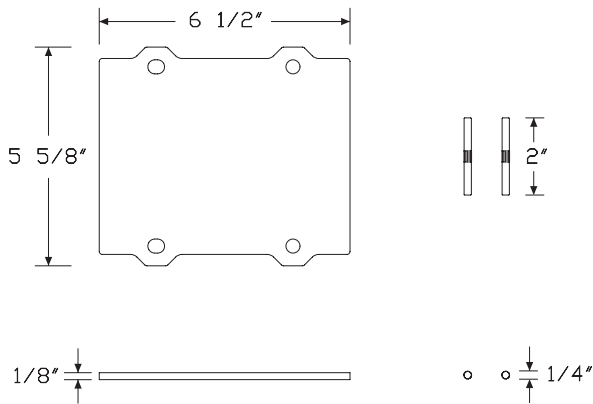

**Specification Information**

**Step 1.**

**FG121.** \$94

# Power Entry, Internal Direct Connect - Floor

FG144.

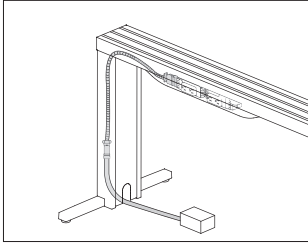

## Product Information

### Description

This power entry connects a building's electrical supply from a wall, floor or column to the power block of the harness with power + data cover located under the chase. It enters the bottom of an end leg or can enter at a chase-to-chase intermediate location by routing up an intermediate leg with infeed cover. Power entry is available in 8-wire and 10-wire configurations and distributes up to 4 20-amp circuits. The power infeed is liquid tight from the power source to the transition coupler in the leg, and flex conduit from the coupler to the power harness. Power entry is UL Listed and Canadian UL Listed.

### Notes

Power entry consumes 1 of 4 modular connection points available on each end of the harness with power + data cover (FG150.).

Licensed electrician must wire power entry.

Power entry does not contain any PVC.

For more planning information using the power entry, see planning guide.

## Dimensions

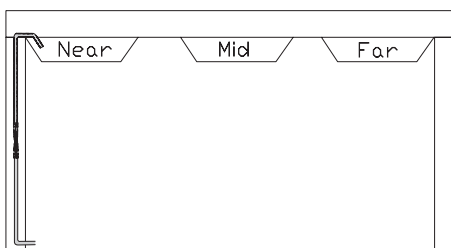
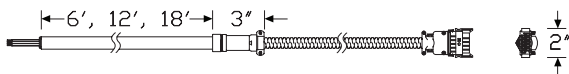

## Specification Information

### Step 1.

**FG144.**

### Step 2. Configuration

- 08** 8-wire, 4-circuit, shared neutral
- 10** 10-wire, 4-circuit, separate neutrals

### Step 3. Chase of Entry Length

- 48** 48" wide
- 60** 60" wide
- 66** 66" wide
- 72** 72" wide
- 84** 84" wide
- 96** 96" wide

### Step 4. Power Harness Location in Chase of Entry

- N** near
- M** mid
- F** far

### Step 5. Length

- 06** 6' long
- 12** 12' long
- 18** 18' long

### Prices for Steps 1-5.

		N06	N12	N18	M06	M12	M18
<b>FG144. 08</b>	<b>48</b>	\$265	391	515	270	396	521
	<b>60</b>	\$265	391	515	278	401	526
	<b>66</b>	\$265	391	515	281	404	528
	<b>72</b>	\$265	391	515	283	406	531
	<b>84</b>	\$265	391	515	292	416	540
	<b>96</b>	\$265	391	515	301	425	547
<b>10</b>	<b>48</b>	\$265	391	515	270	396	521
	<b>60</b>	\$265	391	515	278	401	526
	<b>66</b>	\$265	391	515	281	404	528
	<b>72</b>	\$265	391	515	283	406	531
	<b>84</b>	\$265	391	515	292	416	540
	<b>96</b>	\$265	391	515	301	425	547

Power Entry, Internal Direct  
Connect - Floor *continued*

		<b>F06</b>	<b>F12</b>	<b>F18</b>
<b>Canvas Vista™ Energy Distribution</b>	<b>FG144. 08 48</b>	\$278	401	526
	<b>60</b>	\$288	411	537
	<b>66</b>	\$293	418	542
	<b>72</b>	\$298	423	547
	<b>84</b>	\$318	441	564
	<b>96</b>	\$336	459	579
	<b>10 48</b>	\$278	401	526
	<b>60</b>	\$288	411	537
	<b>66</b>	\$293	418	542
	<b>72</b>	\$298	423	547
	<b>84</b>	\$318	441	564
	<b>96</b>	\$336	459	579

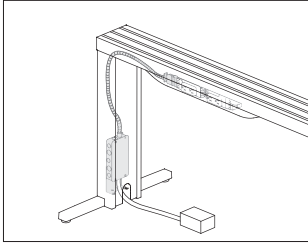

**Product Information**

**Description**

This floor power entry connects a building's electrical supply from a junction box located inside the end leg to the end of the harness with power + data cover located under the chase. It connects to the modular connection location on the end of a power harness and includes a junction box. Power entry is available in 8-wire and 10-wire configurations and distributes up to 4 20-amp circuits. Power entry is UL Listed and Canadian UL Listed.

**Notes**

- ..... Licensed electrician must wire power entry.
- ..... Power entry consumes 1 of 4 modular connection points available on each end of the harness with power + data cover (FG150.).
- ..... Harness with power + data cover (FG150.) is required. Order separately.
- ..... This infeed comes in 1 of 5 lengths and must be field cut to the appropriate length.
- ..... When power entry is at a chase-to-chase intermediate connection, a structural chase T-leg, end (FG119.1A) or nonstructural chase post leg, end (FG117.1A) will need to be used, depending on the application.
- ..... For more planning information using the power entry, see planning guide.

**Dimensions**

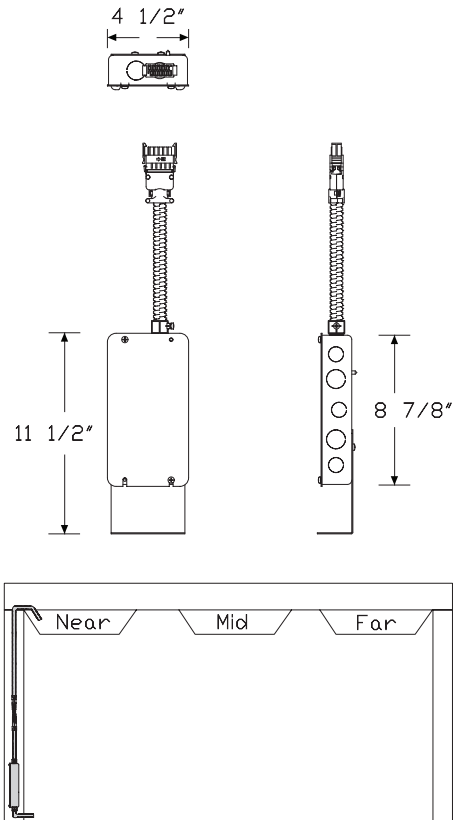

# Power Entry, New York - Floor

continued

Canvas Vista™ Energy Distribution

## Specification Information

Step 1.

**FG141.**

Step 2. Configuration

**08** 8-wire, 4-circuit, shared neutral

**10** 10-wire, 4-circuit, separate neutrals

Step 3. Chase of Entry Length

**48** 48" wide

**60** 60" wide

**66** 66" wide

**72** 72" wide

**84** 84" wide

**96** 96" wide

Step 4. Power Harnes Location in Chase of Entry

**N** near

**M** mid

**F** far

Prices for Steps 1-4.

	<b>N</b>	<b>M</b>	<b>F</b>
<b>FG141. 08 48</b>	\$379	379	379
<b>60</b>	\$389	389	389
<b>66</b>	\$394	394	394
<b>72</b>	\$399	399	399
<b>84</b>	\$410	410	410
<b>96</b>	\$421	421	421
<b>10 48</b>	\$379	379	379
<b>60</b>	\$389	389	389
<b>66</b>	\$394	394	394
<b>72</b>	\$399	399	399
<b>84</b>	\$410	410	410
<b>96</b>	\$421	421	421

# Power Entry - Ceiling

FG142.

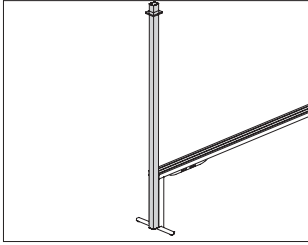

### Product Information

#### Description

This power entry connects a ceiling electrical supply to the end of the harness with power + data cover located under the chase. It is available in 8-wire and 10-wire configurations and distributes up to 4 20-amp circuits. It comes with a 10' pole that can be field cut to the appropriate length and ceiling trim. Power entry is UL Listed and Canadian UL Listed.

#### Notes

Power entry consumes 1 of 4 modular connection points available on each end of the harness with power + data cover (FG150.).

Licensed electrician must wire power entry.

Power pole is plastic.

For cable capacity, see planning guide.

#### Dimensions

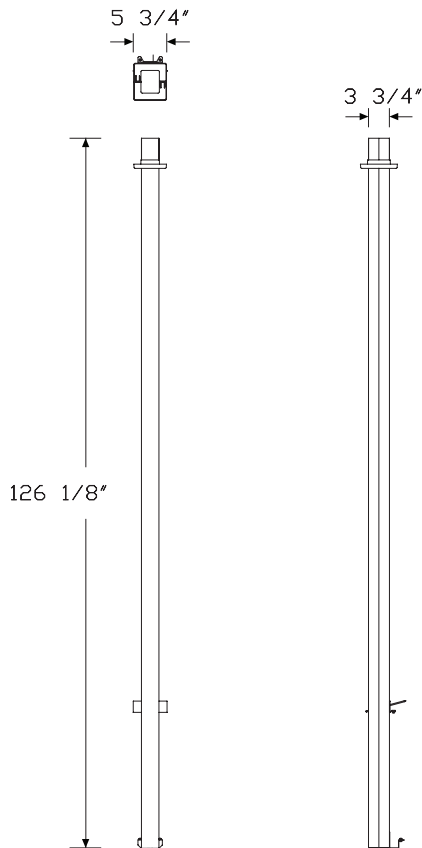

### Specification Information

#### Step 1.

**FG142.**

#### Step 2. Configuration

- 08** 8-wire, 4-circuit, shared neutral
- 10** 10-wire, 4-circuit, separate neutrals
- N** nonpowered

#### Prices for Steps 1-2.

<b>FG142. 08</b>	\$1216
<b>10</b>	\$1216
<b>N</b>	\$684

#### Step 3. Finish

<b>8Q</b>	folkstone grey	+\$0
<b>91</b>	white	+\$0
<b>98</b>	studio white	+\$0
<b>BK</b>	black	+\$0
<b>CL</b>	cool grey neutral	+\$0
<b>G1</b>	graphite	+\$0
<b>WL</b>	sandstone	+\$0
<b>WN</b>	warm grey neutral	+\$0

# Harness with Power + Data Cover FG150.

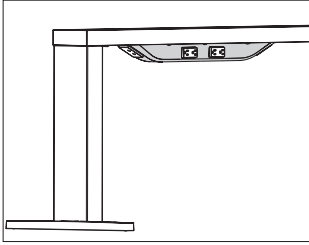

Canvas Vista™ Energy Distribution

## Product Information

### Description

This power harness with cover attaches to the underside of the chase. Harness accepts up to 4 duplex receptacles, 2 on each side of the chase, providing up to 4 outlets on each side. Receptacles in this module are rated for 15 or 20 amps. Knockouts at each end of the cover can be removed to accept data. Harness is UL Listed and Canadian UL Listed.

### Notes

Order receptacles (FG152., FG152M., FG153., FG153M.) separately. To connect harnesses through the chase, order power jumpers (FG154.) separately.

Harness with power + data cover can be placed in right, center, or left locations on the chase.

For chase lengths 48", 60", and 66", only 1 harness can be specified.

For chase lengths 72", 84", and 96", 2 harnesses can be specified within a single chase. Locations must be left and right.

Data exits through knockouts on each end of the cover. Data cable capacity depends on the data faceplate used.

Power + data cover accepts Modular Furniture Standard faceplates. It does not accept NEMA data faceplates. Leviton® 49910-SE2 can be used; for additional clearance for making data connections the extended depth Leviton 49910-EE4 can be used. The faceplate reducer (G1189.A) is not required when using these faceplates.

## Dimensions

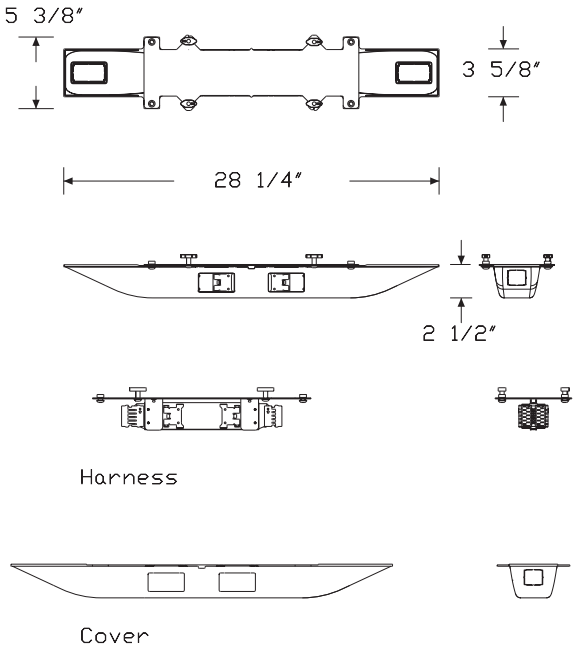

# Harness with Power + Data Cover

continued

## Specification Information

Step 1.

**FG150.**

Step 2. Configuration

**08** 8-wire, 4-circuit, shared neutral

**10** 10-wire, 4-circuit, separate neutrals

Prices for Steps 1-2.

**FG150. 08** \$258

**10** \$258

Step 3. Finish

**BK** black +\$0

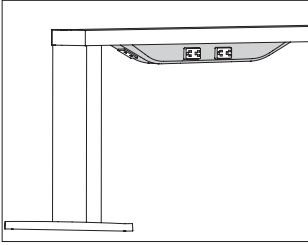

Canvas Vista™ Energy Distribution

**Product Information**

**Description**

This unit is a metal junction box and cover that is used in place of the harness with power + data cover. Cover for unused data opening is included.

**Notes**

- Chicago solution is compatible with Decora® receptacles.
- When using the Chicago solution, do not order the harness with power + data cover (FG150.), receptacles or jumpers.
- Licensed electrician must wire the Chicago solution.
- Chicago solution box has knockouts at each end for data.

**Dimensions**

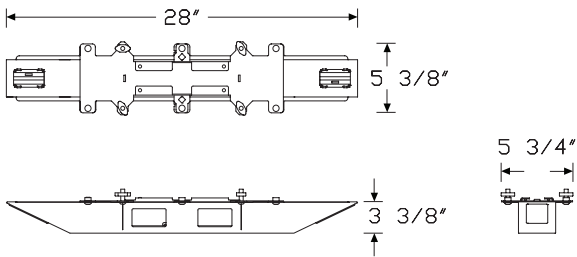

**Specification Information**

**Step 1.**

**FG157.** \$507

**Step 2. Finish**

**BK** black +\$0

**Power Jumper - Consistent Chase Widths, Chase-to-Chase FG154.**

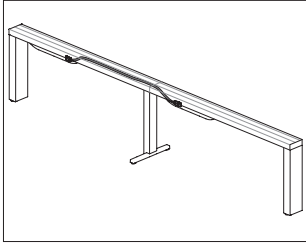

**Product Information**

**Description**

This power jumper distributes power from one harness with power + data cover to another. It connects power from one chase to another chase with consistent length. Jumper connects into the end of a power harness. It is available in 8-wire and 10-wire configurations and distributes 4 20-amp circuits. Power jumper is UL Listed and Canadian UL Listed.

**Notes**

Power jumper consumes 1 of 4 modular connection points available on each end of the harness with power + data cover (FG150.).  
 For chase lengths 72", 84", and 96", 2 harnesses can be specified within a single chase. Locations must be left and right. Order power jumper-within single chase width (FG154.S) separately.  
 Order harness with power + data cover (FG150.) separately.

**Dimensions**

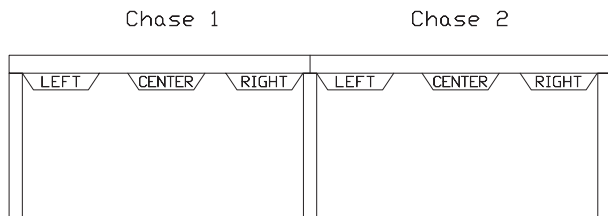
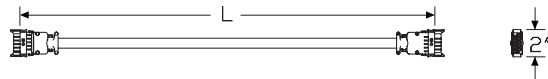
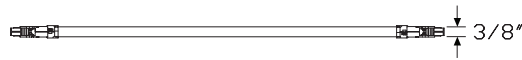

**Specification Information**

**Step 1.**

**FG154.C**

**Step 2. Configuration**

- 08** 8-wire, 4-circuit, shared neutral
- 10** 10-wire, 4-circuit, separate neutrals

**Step 3. Chase Length**

- 48** 48" wide
- 60** 60" wide
- 66** 66" wide
- 72** 72" wide
- 84** 84" wide
- 96** 96" wide

**Step 4. Power Locations Chase-to-Chase**

- 1** (left to left) or (center to center) or (right to right)
- 2** (left to center) or (center to right)
- 3** (left to right)
- 4** (center to left) or (right to center)
- 5** (right to left)

**Prices for Steps 1-4.**

		<b>1</b>	<b>2</b>	<b>3</b>	<b>4</b>	<b>5</b>
<b>FG154.C 08</b>	<b>48</b>	\$106	110	117	100	92
	<b>60</b>	\$121	134	145	107	92
	<b>66</b>	\$129	143	167	110	92
	<b>72</b>	\$136	154	190	115	92
	<b>84</b>	\$150	192	240	122	92
	<b>96</b>	\$176	229	290	130	92
<b>10</b>	<b>48</b>	\$106	110	117	100	92
	<b>60</b>	\$121	134	145	107	92
	<b>66</b>	\$129	143	167	110	92
	<b>72</b>	\$136	154	190	115	92
	<b>84</b>	\$150	192	240	122	92
	<b>96</b>	\$176	229	290	130	92

# Power Jumper - Within Single Chase

FG154.

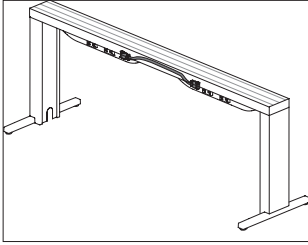

Canvas Vista™ Energy Distribution

### Product Information

**Description**  
 This power jumper distributes power from one harness with power + data cover to another within 1 chase length. Jumper connects into the end of a power harness. It is available in 8-wire and 10-wire configurations and distributes 4 20-amp circuits. Power jumper is UL Listed and Canadian UL Listed.

**Notes**  
 Power jumper consumes 1 of 4 modular connection points available on each end of the harness with power + data cover (FG150.).  
 This jumper can only be installed on chase lengths 72", 84", and 96" where 2 harnesses can be specified within a single chase. Locations must be left and right.  
 Order harness with power + data cover (FG150.) separately.

### Dimensions

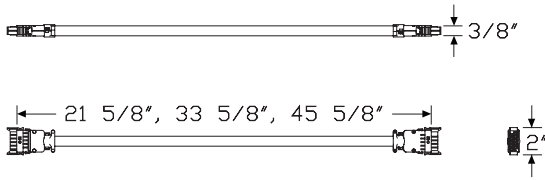

### Specification Information

**Step 1.**

#### FG154.S

**Step 2. Configuration**

- 08** 8-wire, 4-circuit, shared neutral
- 10** 10-wire, 4-circuit, separate neutrals

**Step 3. Chase Length**

- 72** 72" wide
- 84** 84" wide
- 96** 96" wide

**Prices for Steps 1-3.**

	72	84	96
<b>FG154.S 08</b>	\$86	103	117
<b>10</b>	\$86	103	117

# Power Jumper - Inconsistent Chase Widths, Chase-to-Chase

FG154.

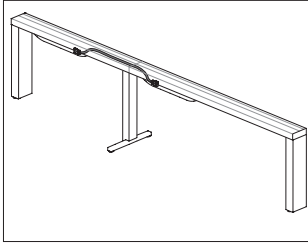

## Product Information

### Description

This power jumper distributes power from one harness with power + data cover to another. It connects power from one chase to another chase with inconsistent length. It is available in 8-wire and 10-wire configurations and distributes 4 20-amp circuits. Power jumper is UL Listed and Canadian UL Listed.

### Notes

To specify power jumpers for inconsistent chase lengths, see Power Jumper Matrix in the planning guide.

Power jumper consumes 1 of 4 modular connection points available on each end of the harness with power + data cover (FG150.).

Harness with power + data cover (FG150.) can be placed in the left, center, or right location underneath each chase.

Order harness with power + data cover (FG150.) separately.

### Dimensions

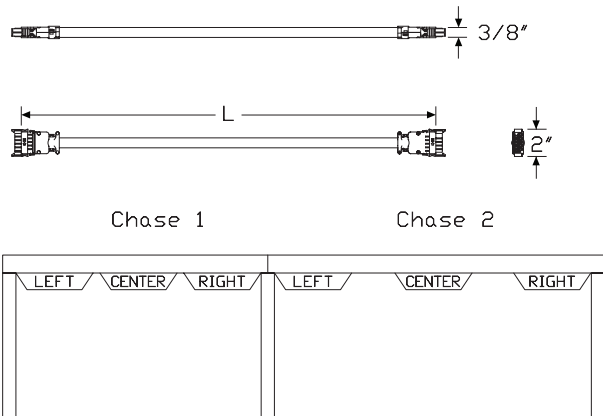

## Specification Information

### Step 1.

**FG154.D**

### Step 2. Configuration

<b>08</b>	8-wire, 4-circuit, shared neutral
<b>10</b>	10-wire, 4-circuit, separate neutrals

### Step 3. Jumper Length

<b>28</b>	28" long
<b>32</b>	32" long
<b>37</b>	37" long
<b>38</b>	38" long
<b>41</b>	41" long
<b>43</b>	43" long
<b>44</b>	44" long
<b>46</b>	46" long
<b>47</b>	47" long
<b>49</b>	49" long
<b>50</b>	50" long
<b>52</b>	52" long
<b>53</b>	53" long
<b>55</b>	55" long
<b>56</b>	56" long
<b>58</b>	58" long
<b>59</b>	59" long
<b>61</b>	61" long
<b>62</b>	62" long
<b>64</b>	64" long
<b>65</b>	65" long
<b>67</b>	67" long
<b>70</b>	70" long
<b>71</b>	71" long
<b>73</b>	73" long
<b>74</b>	74" long
<b>76</b>	76" long
<b>77</b>	77" long
<b>79</b>	79" long
<b>82</b>	82" long
<b>83</b>	83" long
<b>85</b>	85" long
<b>86</b>	86" long
<b>88</b>	88" long
<b>89</b>	89" long
<b>94</b>	94" long
<b>95</b>	95" long
<b>98</b>	98" long

# Power Jumper - Inconsistent Chase Widths, Chase-to-Chase

continued

Canvas Vista™ Energy Distribution

- 100 100" long
- 101 101" long
- 106 106" long
- 107 107" long
- 112 112" long
- 118 118" long
- 130 130" long
- 142 142" long

Prices for Steps 1-3.							
		<b>28</b>	<b>32</b>	<b>37</b>	<b>38</b>	<b>41</b>	<b>43</b>
<b>FG154.D</b>	<b>08</b>	\$92	100	106	107	110	112
	<b>10</b>	\$92	100	106	107	110	112
		<b>44</b>	<b>46</b>	<b>47</b>	<b>49</b>	<b>50</b>	<b>52</b>
<b>FG154.D</b>	<b>08</b>	\$115	117	119	121	122	124
	<b>10</b>	\$115	117	119	121	122	124
		<b>53</b>	<b>55</b>	<b>56</b>	<b>58</b>	<b>59</b>	<b>61</b>
<b>FG154.D</b>	<b>08</b>	\$127	129	130	132	134	136
	<b>10</b>	\$127	129	130	132	134	136
		<b>62</b>	<b>64</b>	<b>65</b>	<b>67</b>	<b>70</b>	<b>71</b>
<b>FG154.D</b>	<b>08</b>	\$137	139	140	142	145	147
	<b>10</b>	\$137	139	140	142	145	147
		<b>73</b>	<b>74</b>	<b>76</b>	<b>77</b>	<b>79</b>	<b>82</b>
<b>FG154.D</b>	<b>08</b>	\$150	151	152	154	158	167
	<b>10</b>	\$150	151	152	154	158	167
		<b>83</b>	<b>85</b>	<b>86</b>	<b>88</b>	<b>89</b>	<b>94</b>
<b>FG154.D</b>	<b>08</b>	\$170	176	179	183	187	190
	<b>10</b>	\$170	176	179	183	187	190
		<b>95</b>	<b>98</b>	<b>100</b>	<b>101</b>	<b>106</b>	<b>107</b>
<b>FG154.D</b>	<b>08</b>	\$192	198	202	204	215	217
	<b>10</b>	\$192	198	202	204	215	217
				<b>112</b>	<b>118</b>	<b>130</b>	<b>142</b>
<b>FG154.D</b>	<b>08</b>			\$227	240	266	290
	<b>10</b>			\$227	240	266	290

Receptacle, 4-Circuit, 15 Amp  
(Package of 4)

FG152.

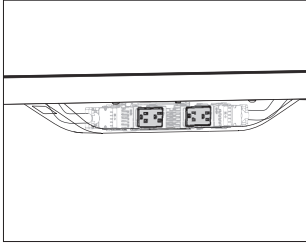

**Product Information**

**Description**

This receptacle locks into the power harness of the harness with power + data cover under the chase. It is UL Listed and Canadian UL Listed. Package contains 4 receptacles.

**Dimensions**

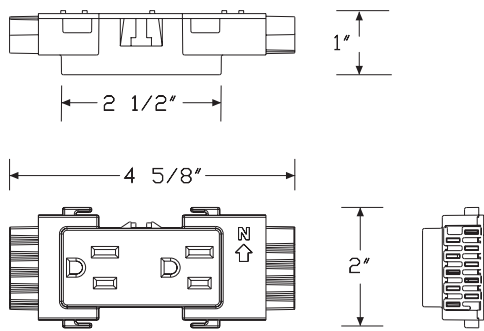

**Specification Information**

**Step 1.**

**FG152.**

**Step 2. Configuration**

- AN** 8-wire duplex, shared neutral, circuit a
- BN** 8-wire duplex, shared neutral, circuit b
- CN** 8-wire duplex, shared neutral, circuit c
- DN** 8-wire duplex, shared neutral, circuit d
- AG** 8-wire duplex, shared neutral, circuit a, isolated ground
- BG** 8-wire duplex, shared neutral, circuit b, isolated ground
- CG** 8-wire duplex, shared neutral, circuit c, isolated ground
- DG** 8-wire duplex, shared neutral, circuit d, isolated ground
- 1N** 10-wire duplex, independent neutral, circuit 1
- 2N** 10-wire duplex, independent neutral, circuit 2
- 3N** 10-wire duplex, independent neutral, circuit 3
- 4N** 10-wire duplex, independent neutral, circuit 4
- 1G** 10-wire duplex, independent neutral, circuit 1, isolated ground
- 2G** 10-wire duplex, independent neutral, circuit 2, isolated ground
- 3G** 10-wire duplex, independent neutral, circuit 3, isolated ground
- 4G** 10-wire duplex, independent neutral, circuit 4, isolated ground

**Prices for Steps 1-2.**

<b>FG152. AN</b>	\$135
<b>BN</b>	\$135
<b>CN</b>	\$135
<b>DN</b>	\$135
<b>AG</b>	\$135
<b>BG</b>	\$135
<b>CG</b>	\$135
<b>DG</b>	\$135
<b>1N</b>	\$135
<b>2N</b>	\$135
<b>3N</b>	\$135
<b>4N</b>	\$135
<b>1G</b>	\$135
<b>2G</b>	\$135
<b>3G</b>	\$135
<b>4G</b>	\$135

**Step 3. Finish**

<b>BK</b> black	+ \$0
-----------------	-------

# Controlled Receptacle, 4-Circuit, FG152M 15 Amp (Package of 4)

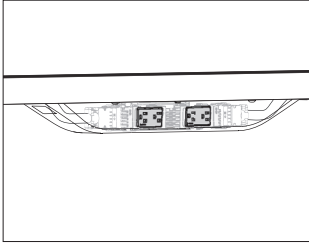

Canvas Vista™ Energy Distribution

## Product Information

### Description

This receptacle is to be used for ASHRAE 90.1 and Title 24 compliance. A controlled receptacle should be used for any receptacle that is under automated control by the energy management system. The receptacle locks into the power harness of the harness with power + data cover under the chase. It is UL Listed and Canadian UL Listed. Package contains 4 receptacles.

### Notes

This receptacle does not have any built-in control, only the controlled label. It must be controlled by another means.

### Dimensions

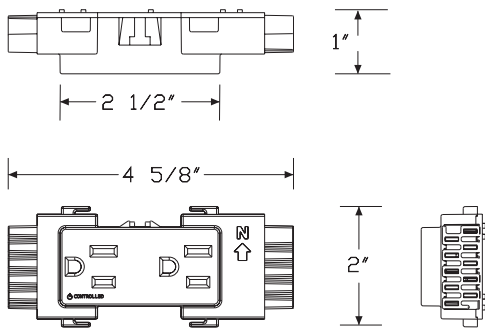

## Specification Information

### Step 1.

#### FG152M.

### Step 2. Configuration

<b>AN</b>	8-wire duplex, shared neutral, circuit a
<b>BN</b>	8-wire duplex, shared neutral, circuit b
<b>CN</b>	8-wire duplex, shared neutral, circuit c
<b>DN</b>	8-wire duplex, shared neutral, circuit d
<b>AG</b>	8-wire duplex, shared neutral, circuit a, isolated ground
<b>BG</b>	8-wire duplex, shared neutral, circuit b, isolated ground
<b>CG</b>	8-wire duplex, shared neutral, circuit c, isolated ground
<b>DG</b>	8-wire duplex, shared neutral, circuit d, isolated ground
<b>1N</b>	10-wire duplex, independent neutral, circuit 1
<b>2N</b>	10-wire duplex, independent neutral, circuit 2
<b>3N</b>	10-wire duplex, independent neutral, circuit 3
<b>4N</b>	10-wire duplex, independent neutral, circuit 4
<b>1G</b>	10-wire duplex, independent neutral, circuit 1, isolated ground
<b>2G</b>	10-wire duplex, independent neutral, circuit 2, isolated ground
<b>3G</b>	10-wire duplex, independent neutral, circuit 3, isolated ground
<b>4G</b>	10-wire duplex, independent neutral, circuit 4, isolated ground

### Prices for Steps 1-2.

<b>FG152M. AN</b>	\$135
<b>BN</b>	\$135
<b>CN</b>	\$135
<b>DN</b>	\$135
<b>AG</b>	\$135
<b>BG</b>	\$135
<b>CG</b>	\$135
<b>DG</b>	\$135
<b>1N</b>	\$135
<b>2N</b>	\$135
<b>3N</b>	\$135
<b>4N</b>	\$135
<b>1G</b>	\$135
<b>2G</b>	\$135
<b>3G</b>	\$135
<b>4G</b>	\$135

### Step 3. Finish

<b>BK</b>	black	+\$0
-----------	-------	------

# Receptacle, 20 Amp

FG153.

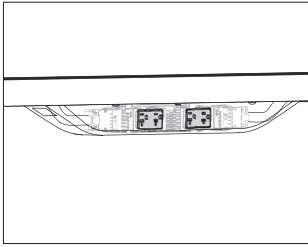

### Product Information

#### Description

This receptacle locks into the power harness of the harness with power + data cover under the chase. It provides power to equipment with a 20-amp standard plug head or cap. It also accepts 15-amp standard plug heads or caps. It is UL Listed and Canadian UL Listed. Package contains 1 receptacle.

#### Notes

Avoid overloading circuit by ensuring total connected load does not exceed 16 amps. If 1 piece of equipment requires all available power, do not use receptacle's second outlet or install additional receptacles on that circuit. In many cases, equipment requiring this receptacle will use all available power.

Harness with power + data cover (FG150.) has knockouts above each receptacle location that will need to be removed for proper cover assembly over the 20-amp receptacles.

### Dimensions

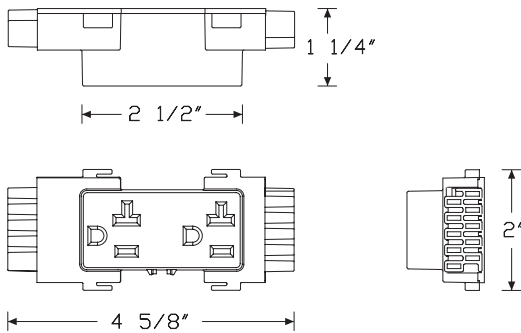

### Specification Information

#### Step 1.

**FG153.**

#### Step 2. Configuration

<b>AN</b>	8-wire duplex, shared neutral, circuit a
<b>BN</b>	8-wire duplex, shared neutral, circuit b
<b>AG</b>	8-wire duplex, shared neutral, circuit a, isolated ground
<b>BG</b>	8-wire duplex, shared neutral, circuit b, isolated ground
<b>1N</b>	10-wire duplex, independent neutral, circuit 1
<b>2N</b>	10-wire duplex, independent neutral, circuit 2
<b>1G</b>	10-wire duplex, independent neutral, circuit 1, isolated ground
<b>2G</b>	10-wire duplex, independent neutral, circuit 2, isolated ground

#### Prices for Steps 1-2.

<b>FG153. AN</b>	\$50
<b>BN</b>	\$50
<b>AG</b>	\$50
<b>BG</b>	\$50
<b>1N</b>	\$50
<b>2N</b>	\$50
<b>1G</b>	\$50
<b>2G</b>	\$50

#### Step 3. Finish

<b>BK</b>	black	+\$0
-----------	-------	------

# Controlled Receptacle, 20 Amp FG153M

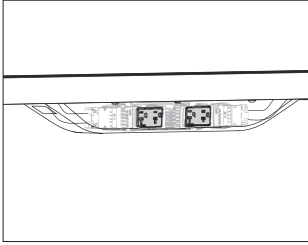

Canvas Vista™ Energy Distribution

## Product Information

### Description

This receptacle is to be used for ASHRAE 90.1 and Title 24 compliance. A controlled receptacle should be used for any receptacle that is under automated control by the energy management system. The receptacle locks into the power harness of the harness with power + data cover under the chase. It provides power to equipment with a 20-amp standard plug head or cap. It also accepts 15-amp standard plug heads or caps. It is UL Listed and Canadian UL Listed. Package contains 1 receptacle.

### Notes

This receptacle does not have any built-in control, only the controlled label. It must be controlled by another means.  
 Avoid overloading circuit by ensuring total connected load does not exceed 16 amps. If 1 piece of equipment requires all available power, do not use receptacle's second outlet or install additional receptacles on that circuit. In many cases, equipment requiring this receptacle will use all available power.  
 Harness with power + data cover (FG150.) has knockouts above each receptacle location that will need to be removed for proper cover assembly over the 20-amp receptacles.

## Dimensions

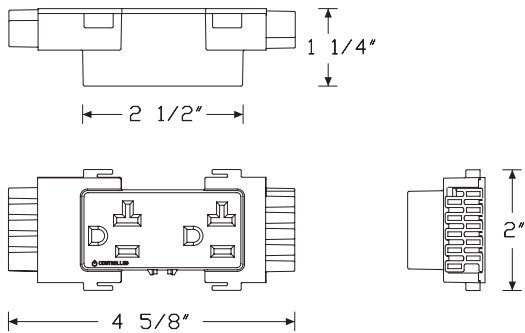

## Specification Information

### Step 1.

#### FG153M.

### Step 2. Configuration

<b>AN</b>	8-wire duplex, shared neutral, circuit a
<b>BN</b>	8-wire duplex, shared neutral, circuit b
<b>AG</b>	8-wire duplex, shared neutral, circuit a, isolated ground
<b>BG</b>	8-wire duplex, shared neutral, circuit b, isolated ground
<b>1N</b>	10-wire duplex, independent neutral, circuit 1
<b>2N</b>	10-wire duplex, independent neutral, circuit 2
<b>1G</b>	10-wire duplex, independent neutral, circuit 1, isolated ground
<b>2G</b>	10-wire duplex, independent neutral, circuit 2, isolated ground

### Prices for Steps 1-2.

<b>FG153M. AN</b>	\$50
<b>BN</b>	\$50
<b>AG</b>	\$50
<b>BG</b>	\$50
<b>1N</b>	\$50
<b>2N</b>	\$50
<b>1G</b>	\$50
<b>2G</b>	\$50

### Step 3. Finish

<b>BK</b> black	+ \$0
-----------------	-------

Receptacle/Data Cover (Package of 2) FG155.

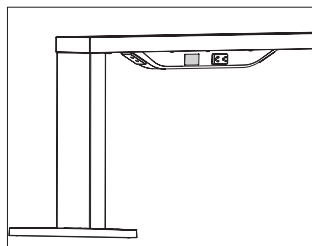

**Product Information**

**Description**

This cover conceals the opening of an unused receptacle and data port on the harness with power + data cover. Finish is black. Package contains 2 covers.

**Notes**

Order harness with power + data cover (FG150.) separately.

**Dimensions**

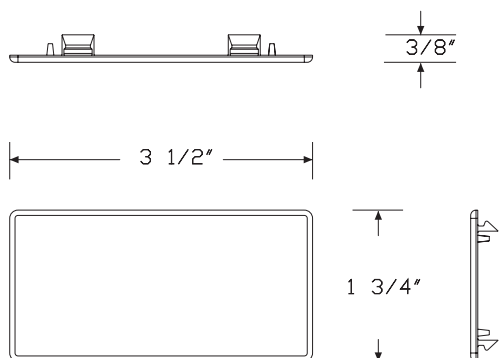

**Specification Information**

**Step 1.**

**FG155.** \$32

**Step 2. Finish**

**BK** black +\$0

Infeed Cover

FG156.

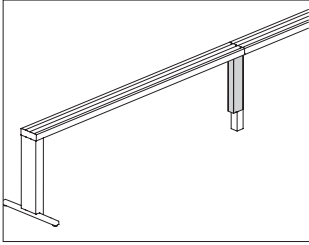

Canvas Vista™ Energy Distribution

**Product Information**

**Description**  
 This metal infeed cover attaches to a nonstructural intermediate post leg or a structural intermediate T-leg to conceal a floor power entry and data cables from the power source to the underside of the chase. Attachment hardware included.

**Notes**  
 Infeed cover attaches only to the structural chase intermediate T-leg (FG119.1B) or nonstructural chase intermediate post leg (FG117.1B), ordered separately.

**Dimensions**

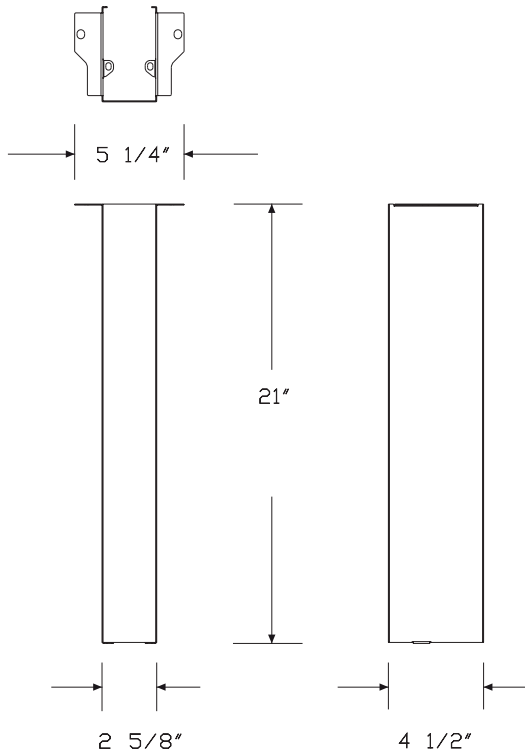

**Specification Information**

**Step 1.**  
**FG156.** \$116

**Step 2. Finish**

**Smooth Paint**

<b>8Q</b>	folkstone grey	+\$0
<b>91</b>	white	+\$0
<b>98</b>	studio white	+\$0
<b>CL</b>	cool grey neutral	+\$0
<b>WL</b>	sandstone	+\$0
<b>WN</b>	warm grey neutral	+\$0

**Metallic Paint**

<b>CN</b>	metallic champagne	+\$0
<b>EH</b>	metallic bronze	+\$0
<b>MS</b>	metallic silver	+\$0

**Sand Texture Paint**

<b>BK</b>	black	+\$0
<b>G1</b>	graphite	+\$0

Data Box, Chase Mounted

FG159.

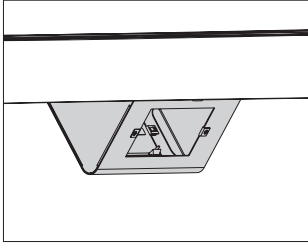

**Product Information**

Description

This data box mounts on the bottom side of the chase if additional data is desired. Housing accepts NEMA data faceplates. It has openings on both sides and comes with 1 cover that can be removed to install a second NEMA data faceplate. Attachment hardware included.

Dimensions

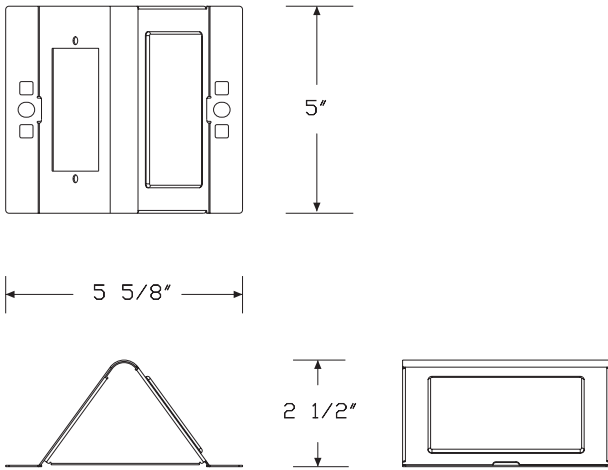

**Specification Information**

Step 1.

**FG159.** \$69

Step 2. Finish

**BK** black +\$0

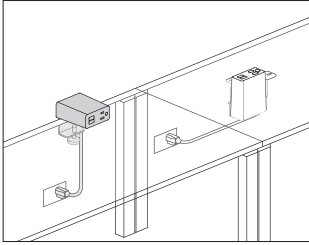

Canvas Vista™ Energy Distribution

**Product Information**

**Description**

This electrical distributor plugs directly into floor, wall, or ceiling drop outlets. Each module configuration presents the same visual appearance. Cable clips and attachment hardware included. Product is UL listed.

**Notes**

Cable clips for cord management are intended for a 1-time installation.

Clamp versions can be reoriented in the field by a technician.

A small LED light illuminates through the USB ports when the USB version is plugged in and powered.

USB ports provide 10-watt power to charge most devices and tablets at full speed.

Cord color is predetermined. For white (G1) finish cords will be white. For graphite (G1) finish cords will be black.

Grommet mount attachment (Y1414.xxxG) does not come with the mini grommet. Order Logic mini grommet (Y1412.) separately, as needed.

**Dimensions**

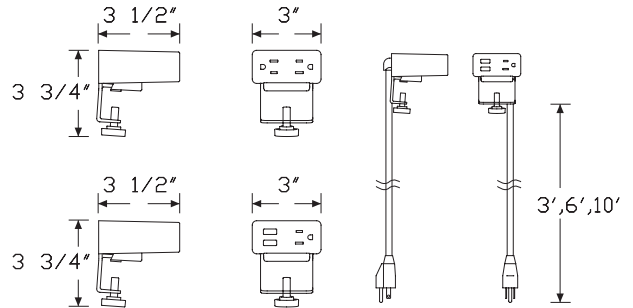

**Surface Clamp**

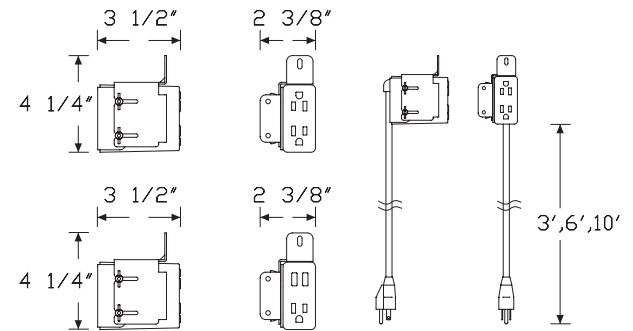

**Grommet Mount**

**Specification Information**

Step 1.

**Y1414.**

Step 2. Configuration

**J** 1 simplex receptacles, 2 powered USB

**K** 2 simplex receptacles

Step 3. Cord/Conduit Length

**03** 3' cord/conduit

**06** 6' cord/conduit

**10** 10' cord/conduit

Step 4. Attachment

**G** grommet mount

**S** surface clamp

Prices for Steps 1-4.

	<b>G</b>	<b>S</b>
<b>Y1414. J 03</b>	\$364	364
<b>06</b>	\$364	364
<b>10</b>	\$374	374
<b>K 03</b>	\$203	203
<b>06</b>	\$203	203
<b>10</b>	\$214	214

Step 5. Finish

<b>BK</b> black <input type="checkbox"/>	+\$0
<b>91</b> white <input type="checkbox"/>	+\$0
<b>98</b> studio white <input type="checkbox"/>	+\$0
<b>G1</b> graphite <input type="checkbox"/>	+\$0

# Logic Mini Grommet

Y1412.

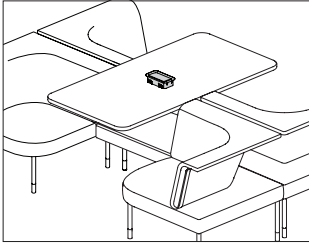

Canvas Vista™ Energy Distribution

### Product Information

**Description**  
This Logic Power Access Solutions™ plastic grommet is available in mini rectangle or mini square configuration. The integrated flaps can hide the things below the surface while also retaining power and data cords.

**Notes**  
This grommet is installed in some HermanMiller applications. Verify your application before ordering grommet separately.

### Dimensions

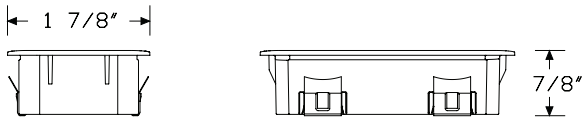
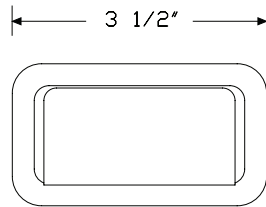

Grommet - Rectangle

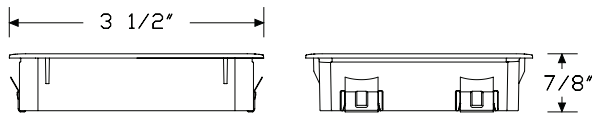
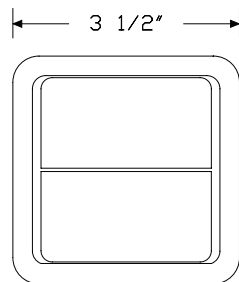

Grommet - Square

### Specification Information

Step 1.

**Y1412.**

### Step 2. Configuration

- 1 mini rectangle grommet
- 2 mini square grommet

### Prices for Steps 1-2.

<b>Y1412. 1</b>	\$29
<b>2</b>	\$33

### Step 3. Finish

<b>91</b>	white	+\$0
<b>98</b>	studio white	+\$0
<b>BK</b>	black	+\$0
<b>G1</b>	graphite	+\$0

# Power Plug Strip

Y1500.

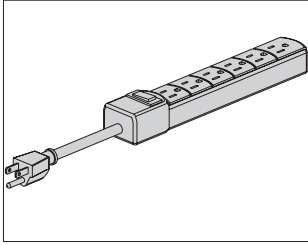

### Product Information

#### Description

This corded power strip provides 6 outlets. It is available with 6' and 10' cord lengths. Power strip is UL Listed and CSA Certified. Finish is black.

#### Notes

The 10' cord (10) length is recommended for use with height adjustable table.

When used with Canvas Vista™, power strip plugs directly into the harness with power + data cover (FG150.) located under the chase.

Order the following products separately:

- Hinged cable trough (Y1300.)
- Vista harness with power + data cover (FG150.)

#### Dimensions

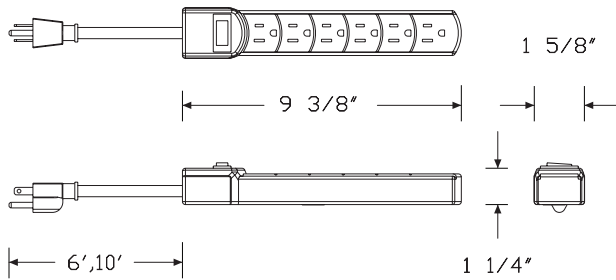

### Specification Information

#### Step 1.

**Y1500.**

#### Step 2. Configuration

**6** 6 AC outlets

#### Step 3. Cord Length

**06** 6' long

**10** 10' long

#### Prices for Steps 1-3.

	<b>06</b>	<b>10</b>
<b>Y1500. 6</b>	\$70	81

# USB Power Module

YT420.

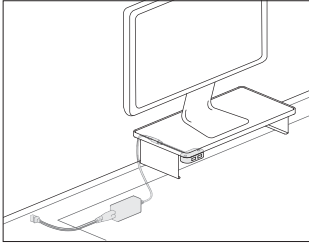

Canvas Vista™ Energy Distribution

## Product Information

**Description**  
 This USB power module provides DC power at the work surface level. It is available in configurations that support USB 2.1 and USB Type C. The module can be mounted to the small and large organizers, shelves, any work surface, and the Canvas Vista™ chase. Cord color is black. Attachment hardware included.

**Notes**  
 USB power module requires a single AC outlet to provide power. Cord lengths are 1 meter from the AC outlet, and 1.8 meters from the module.  
 Vista chase mount attaches to underside of the Canvas Vista chase (FG110.). Attachment hardware included. For additional cable management, order cable manager, under chase (FG199.) separately. For additional information, see Canvas Vista planning guide.

## Dimensions

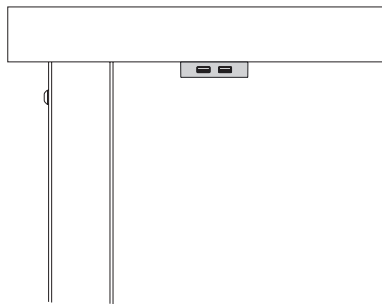
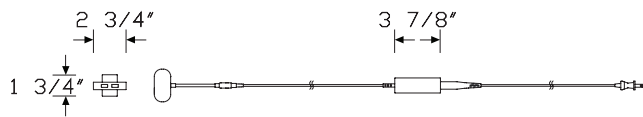

Chase Attachment



Shelf and surface Attachment

## Specification Information

**Step 1.**

**YT420.** A

**Step 2. Configuration**

- A** configured with two standard USB ports, USB 2.1 A
- B** configured with one standard USB 2.1 port and one USB Type C A

**Step 3. Attachment Type**

- 1** shelf and surface attachment A
- 2** chase mount A

Prices for Steps 1-3.

	1	2
<b>YT420. A</b>	\$164	184
<b>B</b>	\$244	262

**Step 4. Finish**

<b>91</b>	white <span style="border: 1px solid black; padding: 0 2px;">A</span>	+\$0
<b>98</b>	studio white <span style="border: 1px solid black; padding: 0 2px;">A</span>	+\$0
<b>BK</b>	black <span style="border: 1px solid black; padding: 0 2px;">A</span>	+\$0
<b>CL</b>	cool grey neutral <span style="border: 1px solid black; padding: 0 2px;">A</span>	+\$0
<b>G1</b>	graphite <span style="border: 1px solid black; padding: 0 2px;">A</span>	+\$0

# Cable Management Clip

FG197.

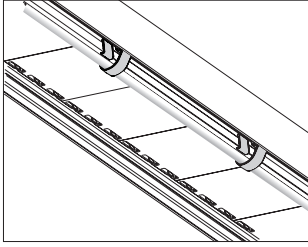

### Product Information

#### Description

These clips snap into tracks on the underside of the chase to route wires and cables. Each clip holds 2 to 3 power cords. Finish is black. Package contains 10 clips.

#### Dimensions

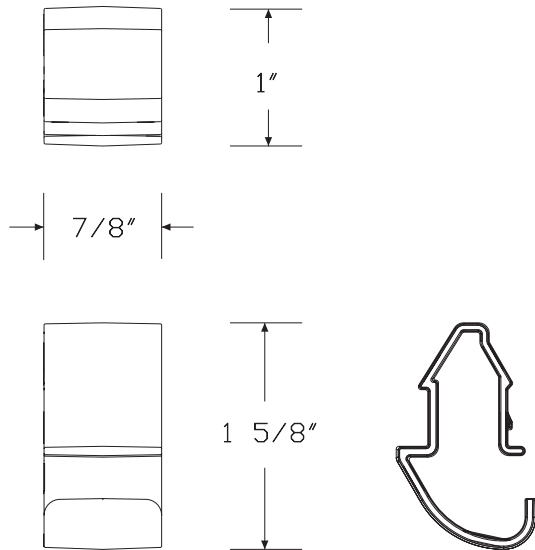

### Specification Information

#### Step 1.

**FG197.** \$95

#### Step 2. Finish

**BK** black +\$0

Cable Manager, Under Chase

FG199.

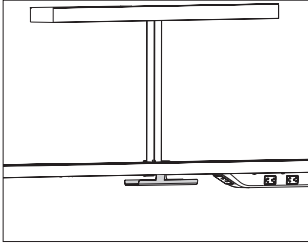

**Product Information**

**Description**

This steel tray attaches to the underside of the chase to hold and conceal cords, cables, and device AC power adapters. Finish is black. Attachment hardware included.

**Notes**

Specify this cable manager for use with the following accessories:

- T-Light (FG600.)
- Display unit (FG111.)
- Ubi USB power module (YT420.)

For additional planning information, see planning guide.

**Dimensions**

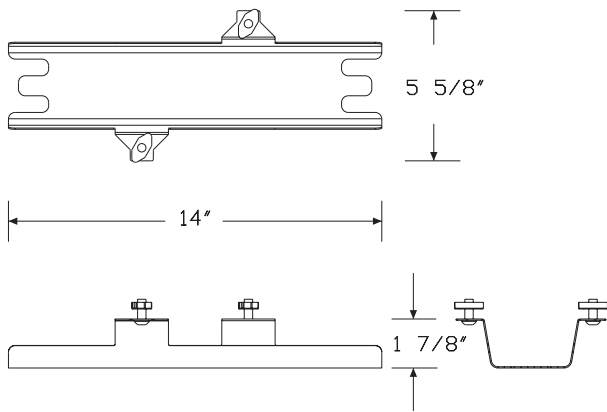

**Specification Information**

**Step 1.**

**FG199.** \$59

**Step 2. Finish**

**BK** black +\$0

# Cable Management Sleeve

FG198.

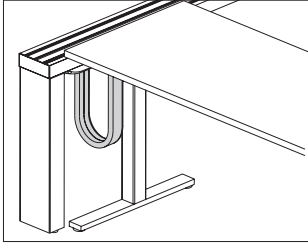

## Product Information

### Description

This sleeve routes cables from the chase to the work surface. One end attaches to a track on the underside of the chase and the other end attaches to the underside of the work surface. It has a plastic track embedded inside the sleeve to allow unrestricted cable movement as a height adjustable work surface moves up and down. Sleeve can hold 2 power cables and 2 data cables. Installation hardware included.

### Notes

For use with fixed height tables, 23" (23) sleeve length must be specified.

For use with height adjustable tables, 42" (42) sleeve length must be specified.

### Dimensions

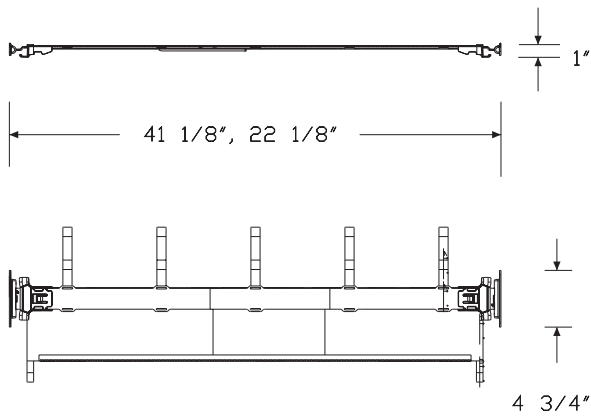

## Specification Information

### Step 1.

**FG198.**

### Step 2. Length

- 23** 23" long (for use with fixed height tables)
- 42** 42" long (for use with height adjustable tables)

### Prices for Steps 1-2.

<b>FG198. 23</b>	\$195
<b>42</b>	\$231

### Step 3. Fabric

Price Category 5	+ \$0
------------------	-------

# Hinged Cable Trough

Y1300.

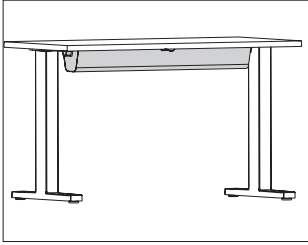

Canvas Vista™ Cable Management

## Product Information

### Description

This sheet metal trough is a stand-alone cable management tray that mounts to the underside of a work surface to hold and conceal cords and cables. It can be used with a Logic Mini unit for cord storage or used alone with cords routed through the ends of the trough. Trough holds cords in place when open.

### Notes

Power strip (Y1500.) is intended to be housed inside the trough for additional power access.

Hinged cable trough works best with a Motia® Vista™ height adjustable table (DV6GT.). Can be used on any other work surface that has the clearance for the overall dimensions listed below.

When specifying a 24"D×54"W table with legs inbound for under surface storage on both ends (2) option, the hinged cable trough option is not available. It is recommended to use the (Y1200.48N) cable trough, ordered separately.

Order the following products separately:

- Power strip (Y1500.)
- Logic Mini (Y1414., Y1412.)

## Dimensions

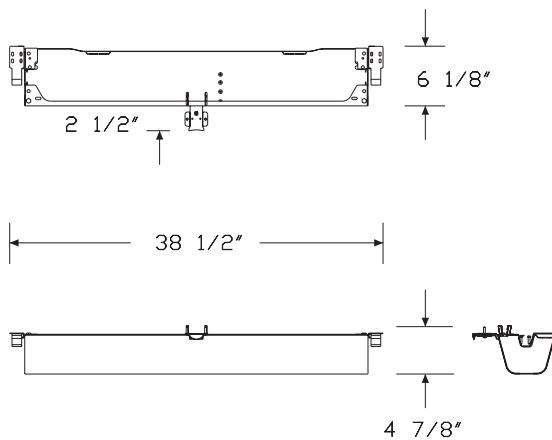

## Specification Information

### Step 1.

**Y1300.** A

### Step 2. Work Surface Depth

**24** for use with 24" deep work surface A  
**30** for use with 30" deep work surface A

### Prices for Steps 1-2.

<b>Y1300. 24</b>	\$196
<b>30</b>	\$213

### Step 3. Finish

#### Smooth Paint

<b>8Q</b>	folkstone grey <span style="border: 1px solid black; padding: 0 2px;">A</span>	+\$0
<b>91</b>	white <span style="border: 1px solid black; padding: 0 2px;">A</span>	+\$0
<b>98</b>	studio white <span style="border: 1px solid black; padding: 0 2px;">A</span>	+\$0
<b>CL</b>	cool grey neutral <span style="border: 1px solid black; padding: 0 2px;">A</span>	+\$0
<b>WL</b>	sandstone <span style="border: 1px solid black; padding: 0 2px;">A</span>	+\$0
<b>WN</b>	warm grey neutral <span style="border: 1px solid black; padding: 0 2px;">A</span>	+\$0

#### Sand Texture Paint

<b>BK</b>	black <span style="border: 1px solid black; padding: 0 2px;">A</span>	+\$0
<b>G1</b>	graphite <span style="border: 1px solid black; padding: 0 2px;">A</span>	+\$0

#### Metallic Paint

<b>CN</b>	metallic champagne <span style="border: 1px solid black; padding: 0 2px;">A</span>	+\$0
<b>EH</b>	metallic bronze <span style="border: 1px solid black; padding: 0 2px;">A</span>	+\$0
<b>MS</b>	metallic silver <span style="border: 1px solid black; padding: 0 2px;">A</span>	+\$0

# Rectangular Work Surface

FGS10.

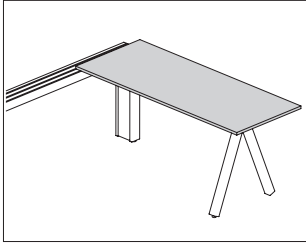

### Product Information

#### Description

This surface attaches to the Canvas Vista™ chase with a pair of tether brackets. It can be attached in parallel and perpendicular applications. Surface can also be freestanding when used with 2 surface supports. It has a laminate top with thermoplastic edge, laminate top with thermoplastic backed plywood edge or veneer top and edge. Laminate and veneer surfaces are 1 1/8" thick or 1 1/4" thick. Surface is available with or without a cutout for the Logic Mini unit. There is a 1" gap between the work surface and the top of the chase to allow for standard plug head and cord passage.

#### Notes

For attachment to the Vista chase, order tether brackets (FG290.) separately.

For use with Canvas Office Landscape®, specify 1 1/4" thick top.

Cutout options for Logic Mini units are left cutout (LC), right cutout (RC), and center cutout (CC). Order Logic mini (Y1414.) and grommet (Y1412.1) separately.

Inbound leg position (2) intended for suspended storage. Order suspended cubby (L2SCF.) and suspended drawer (L2SDF.) separately. Stiffener (FG696.) is required depending on application. See Vista planning guide for specific stiffener guidelines.

When specifying a 24"D x 54"W table with legs inbound for under surface storage on both ends (2) option, the hinged cable trough option is not available. It is recommended to use the (Y1200.48N) cable trough, ordered separately.

Order the following support products separately:

- Surface support, A-leg (FG2B1.)
- Surface support, T-leg (FG2B2.)
- Surface support, post leg (FG2B3.)
- Stiffener (FG696.)
- Chase to surface tether brackets (FG290.)

For additional finish options, see Vary Easy Program in appendices.

### Dimensions

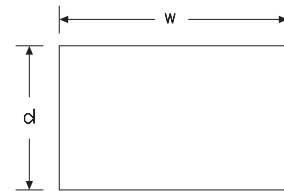

1 1/8"  
1 1/4"

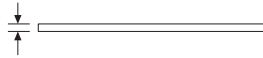

Laminate, Veneer



Legs Outbound



Legs Inbound

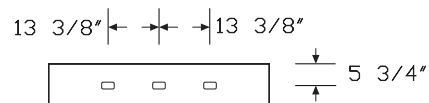

Cutout Locations

Rectangular Work Surface *continued*

**Specification Information**

Step 1.

**FG**

Step 2. Edge

**S10.** squared-edge

Step 3. Depth

**24** 24" deep

**30** 30" deep

Step 4. Width

**48** 48" wide

**54** 54" wide

**60** 60" wide

**66** 66" wide

**72** 72" wide

Step 5. Surface Material

**L** laminate top/thermoplastic edge

**U** laminate top/universal edge

**W** veneer top/veneer edge A

Step 6. Top Thickness

**04** 1¼" thick

**08** 1⅛" thick

Step 7. Leg Location

*For 48" wide (48)*

**1** legs outbound (no surface mounted storage)

*For 54" wide (54), 60" wide (60), 66" wide (66), or 72" wide (72)*

**1** legs outbound (no surface mounted storage)

**2** legs inbound (for under surface storage on both ends)

Prices for Steps 1-7.

	L041	L042	L081	L082	U041	U042
<b>FGS10. 24 48</b>	\$289	—	353	—	289	—
<b>54</b>	\$348	348	413	413	348	348
<b>60</b>	\$384	384	449	449	384	384
<b>66</b>	\$431	431	496	496	431	431
<b>72</b>	\$451	451	519	519	451	451

<b>30 48</b>	\$356	—	410	—	356	—	
<b>54</b>	\$431	431	496	496	431	431	
<b>60</b>	\$451	451	519	519	451	451	
<b>66</b>	\$510	510	565	565	510	510	
<b>72</b>	\$555	555	611	611	555	555	
		<b>U081</b>	<b>U082</b>	<b>W041</b>	<b>W042</b>	<b>W081</b>	<b>W082</b>
<b>FGS10. 24 48</b>	\$353	—	681	—	764	—	
<b>54</b>	\$413	413	810	810	874	874	
<b>60</b>	\$449	449	885	885	967	967	
<b>66</b>	\$496	496	927	927	1066	1066	
<b>72</b>	\$519	519	970	970	1115	1115	
<b>30 48</b>	\$410	—	784	—	881	—	
<b>54</b>	\$496	496	927	927	1066	1066	
<b>60</b>	\$519	519	1016	1016	1115	1115	
<b>66</b>	\$565	565	1146	1146	1202	1202	
<b>72</b>	\$611	611	1236	1236	1292	1292	

# Rectangular Work Surface *continued*

## Step 8.

### Top Finish

*For laminate top/thermoplastic edge (L) or laminate top/universal edge (U)*

<b>76</b>	light brown walnut	+\$0
<b>8Q</b>	folkstone grey	+\$0
<b>91</b>	white	+\$0
<b>98</b>	studio white	+\$0
<b>CL</b>	cool grey neutral	+\$0
<b>HF</b>	inner tone light	+\$0
<b>HM</b>	natural maple	+\$0
<b>HP</b>	light anigre	+\$0
<b>HT</b>	inner tone	+\$0
<b>HX</b>	aged cherry	+\$0
<b>HY</b>	walnut on cherry	+\$0
<b>LA</b>	light ash	+\$0
<b>LBA</b>	clear on ash	+\$0
<b>LBB</b>	oak on ash	+\$0
<b>LBC</b>	walnut on ash	+\$0
<b>LBD</b>	dark brown walnut	+\$0
<b>LBF</b>	neutral twill	+\$0
<b>LBG</b>	sarum twill	+\$0
<b>LBH</b>	earthen twill	+\$0
<b>LBJ</b>	graphite twill	+\$0
<b>LBM</b>	crisp linen	+\$0
<b>LBN</b>	classic linen	+\$0
<b>LBP</b>	casual linen	+\$0
<b>LBQ</b>	white twill	+\$0
<b>LBR</b>	phantom ecru	+\$0
<b>LBS</b>	phantom cocoa	+\$0
<b>LBU</b>	medium matte walnut	+\$0
<b>LBV</b>	warm grey teak	+\$0
<b>LT</b>	light tone	+\$0
<b>LU</b>	soft white	+\$0
<b>MT</b>	medium tone	+\$0
<b>WL</b>	sandstone	+\$0
<b>WN</b>	warm grey neutral	+\$0

### Top/Edge Finish

*For veneer top/veneer edge (W)*

<b>2U</b>	light brown walnut	+\$85
<b>40</b>	dark brown walnut	+\$85
<b>ED</b>	aged cherry	+\$85
<b>EK</b>	medium red walnut	+\$85
<b>ET</b>	clear on ash	+\$85
<b>EU</b>	oak on ash	+\$85
<b>EV</b>	walnut on ash	+\$85
<b>EW</b>	medium matte walnut	+\$85
<b>UL</b>	natural maple	+\$85
<b>UX</b>	walnut on cherry	+\$85

## Step 9. Edge Finish

*For laminate top/thermoplastic edge (L)*

<b>76</b>	light brown walnut	+\$0
<b>8Q</b>	folkstone grey	+\$0
<b>91</b>	white	+\$0
<b>98</b>	studio white	+\$0
<b>BU</b>	black umber	+\$0
<b>CL</b>	cool grey neutral	+\$0
<b>HF</b>	inner tone light	+\$0
<b>HM</b>	natural maple	+\$0
<b>HP</b>	light anigre	+\$0
<b>HT</b>	inner tone	+\$0
<b>HX</b>	aged cherry	+\$0
<b>HY</b>	walnut on cherry	+\$0
<b>LA</b>	light ash	+\$0
<b>LBA</b>	clear on ash	+\$0
<b>LBB</b>	oak on ash	+\$0
<b>LBC</b>	walnut on ash	+\$0
<b>LBD</b>	dark brown walnut	+\$0
<b>LBF</b>	neutral twill	+\$0
<b>LBG</b>	sarum twill	+\$0
<b>LBH</b>	earthen twill	+\$0
<b>LBJ</b>	graphite twill	+\$0
<b>LBK</b>	pewter mesh	+\$0
<b>LBL</b>	steel mesh	+\$0
<b>LBM</b>	crisp linen	+\$0
<b>LBN</b>	classic linen	+\$0
<b>LBP</b>	casual linen	+\$0
<b>LBQ</b>	white twill	+\$0
<b>LBR</b>	phantom ecru	+\$0
<b>LBS</b>	phantom cocoa	+\$0
<b>LBU</b>	medium matte walnut	+\$0
<b>LBV</b>	warm grey teak	+\$0

## Rectangular Work Surface *continued*

<b>LU</b>	soft white	+\$0
<b>MT</b>	medium tone	+\$0
<b>WL</b>	sandstone	+\$0
<b>WN</b>	warm grey neutral	+\$0

---

*For laminate top/universal edge (U)*

<b>PLY</b>	plywood edge	+\$50
------------	--------------	-------

---

Step 10. Power Access Cutout

<b>CC</b>	center cutout for Logic Mini -	+\$55
<b>LC</b>	left cutout for Logic Mini - Y1414 and Y1412	+\$55
<b>NC</b>	no cutout	+\$0
<b>RC</b>	right cutout for Logic Mini - Y1414 and Y1412	+\$55

Peninsula Surface, D-Shaped

FGS36.

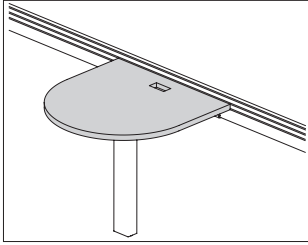

**Product Information**

**Description**

This squared-edge peninsula surface attaches to the Canvas Vista™ chase with a pair of tether brackets and requires a support leg. It has a laminate top with thermoplastic edge or veneer top and edge. Laminate and veneer surfaces are 1 1/8" thick or 1 1/4" thick. Surface is available with or without a cutout for the Logic Mini unit. Surface cannot stand alone. When tethered to the chase there is a 1" gap between the work surface and the top of the chase to allow for standard plug head and cord passage.

**Notes**

For attachment to the Vista chase, order tether brackets (FG290.) separately.

Stiffener is not needed.

Surface has center cutout (CC) option for Logic Mini unit. Order Logic mini (Y1414.) and grommet (Y1412.1) separately.

For cable management with optional Logic, cable management channel (FT19C.o8) can be used. Order separately.

For use with Canvas Office Landscape®, specify 1 1/4" thick top.

Order the following support products separately:

- Surface support, post leg (FG2B3.)
- Chase to surface tether brackets (FG290.)

For additional finish options, see Vary Easy Program in appendices.

For support and planning information, see planning guide.

**Dimensions**

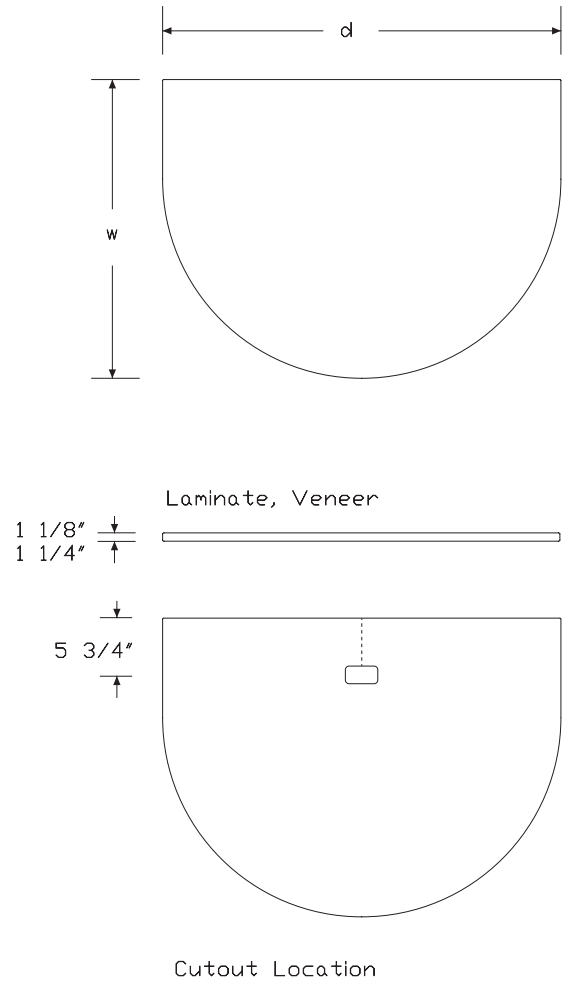

# Peninsula Surface, D-Shaped

continued

Canvas Vista™ Work Surfaces

Specification Information				
Step 1.				
<b>FG</b>				
Step 2. Edge				
<b>S36.</b> squared-edge				
Step 3. Depth				
<b>36</b>	36" deep			
<b>42</b>	42" deep			
<b>48</b>	48" deep			
Step 4. Width				
<i>For 36" deep (36) or 42" deep (42)</i>				
<b>30</b>	30" wide			
<i>For 48" deep (48)</i>				
<b>36</b>	36" wide			
Step 5. Surface Material				
<b>L</b>	laminate top/thermoplastic edge			
<b>W</b>	veneer top/veneer edge <input type="checkbox"/> <b>A</b>			
Step 6. Top Thickness				
<b>04</b>	1 1/4" thick			
<b>08</b>	1 1/8" thick			
Prices for Steps 1-6.				
	<b>L04</b>	<b>L08</b>	<b>W04</b>	<b>W08</b>
<b>FGS36. 36 30</b>	\$522	578	973	1029
<b>42 30</b>	\$598	654	1115	1170
<b>48 36</b>	\$674	730	1257	1312

Step 7.		
Top Finish		
<i>For laminate top/thermoplastic edge (L)</i>		
<b>76</b>	light brown walnut	+\$0
<b>8Q</b>	folkstone grey	+\$0
<b>91</b>	white	+\$0
<b>98</b>	studio white	+\$0
<b>CL</b>	cool grey neutral	+\$0
<b>HF</b>	inner tone light	+\$0
<b>HM</b>	natural maple	+\$0
<b>HP</b>	light anigre	+\$0
<b>HT</b>	inner tone	+\$0
<b>HX</b>	aged cherry	+\$0
<b>HY</b>	walnut on cherry	+\$0
<b>LA</b>	light ash	+\$0
<b>LBA</b>	clear on ash	+\$0
<b>LBB</b>	oak on ash	+\$0
<b>LBC</b>	walnut on ash	+\$0
<b>LBD</b>	dark brown walnut	+\$0
<b>LBF</b>	neutral twill	+\$0
<b>LBG</b>	sarum twill	+\$0
<b>LBH</b>	earthen twill	+\$0
<b>LBJ</b>	graphite twill	+\$0
<b>LBM</b>	crisp linen	+\$0
<b>LBN</b>	classic linen	+\$0
<b>LBP</b>	casual linen	+\$0
<b>LBQ</b>	white twill	+\$0
<b>LBR</b>	phantom ecru	+\$0
<b>LBS</b>	phantom cocoa	+\$0
<b>LBU</b>	medium matte walnut	+\$0
<b>LBV</b>	warm grey teak	+\$0
<b>LT</b>	light tone	+\$0
<b>LU</b>	soft white	+\$0
<b>MT</b>	medium tone	+\$0
<b>WL</b>	sandstone	+\$0
<b>WN</b>	warm grey neutral	+\$0

# Peninsula Surface, D-Shaped

continued

Top/Edge Finish		
<i>For veneer top/veneer edge (W)</i>		
<b>2U</b>	light brown walnut	+\$85
<b>40</b>	dark brown walnut	+\$85
<b>ED</b>	aged cherry	+\$85
<b>EK</b>	medium red walnut	+\$85
<b>ET</b>	clear on ash	+\$85
<b>EU</b>	oak on ash	+\$85
<b>EV</b>	walnut on ash	+\$85
<b>EW</b>	medium matte walnut	+\$85
<b>UL</b>	natural maple	+\$85
<b>UX</b>	walnut on cherry	+\$85

Step 8. Edge Finish		
<i>For laminate top/thermoplastic edge (L)</i>		
<b>76</b>	light brown walnut	+\$0
<b>8Q</b>	folkstone grey	+\$0
<b>91</b>	white	+\$0
<b>98</b>	studio white	+\$0
<b>BU</b>	black umber	+\$0
<b>CL</b>	cool grey neutral	+\$0
<b>HF</b>	inner tone light	+\$0
<b>HM</b>	natural maple	+\$0
<b>HP</b>	light anigre	+\$0
<b>HT</b>	inner tone	+\$0
<b>HX</b>	aged cherry	+\$0
<b>HY</b>	walnut on cherry	+\$0
<b>LA</b>	light ash	+\$0
<b>LBA</b>	clear on ash	+\$0
<b>LBB</b>	oak on ash	+\$0
<b>LBC</b>	walnut on ash	+\$0
<b>LBD</b>	dark brown walnut	+\$0
<b>LBF</b>	neutral twill	+\$0
<b>LBG</b>	sarum twill	+\$0
<b>LBH</b>	earthen twill	+\$0
<b>LBJ</b>	graphite twill	+\$0
<b>LBK</b>	pewter mesh	+\$0
<b>LBL</b>	steel mesh	+\$0
<b>LBM</b>	crisp linen	+\$0
<b>LBN</b>	classic linen	+\$0
<b>LBP</b>	casual linen	+\$0
<b>LBQ</b>	white twill	+\$0
<b>LBR</b>	phantom ecru	+\$0
<b>LBS</b>	phantom cocoa	+\$0
<b>LBU</b>	medium matte walnut	+\$0
<b>LBV</b>	warm grey teak	+\$0
<b>LU</b>	soft white	+\$0

<b>MT</b>	medium tone	+\$0
<b>WL</b>	sandstone	+\$0
<b>WN</b>	warm grey neutral	+\$0

Step 9. Power Access Cutout		
<b>CC</b>	center cutout for Logic Mini -	+\$55
<b>NC</b>	no cutout	+\$0

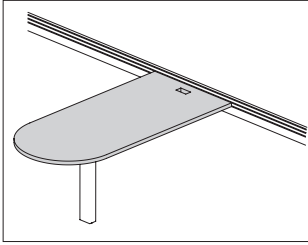

**Product Information**

**Description**

This squared-edge peninsula surface attaches to the Canvas Vista™ chase with a pair of tether brackets and requires a surface support leg. It has a laminate top with thermoplastic edge or veneer top and edge. Laminate and veneer surfaces are 1 1/8" thick or 1 1/4" thick. Surface is available with or without a cutout for the Logic Mini unit. Surface cannot stand alone. When tethered to the chase there is a 1" gap between the work surface and the top of the chase to allow for standard plug head and cord passage.

**Notes**

For attachment to the Vista chase, order tether brackets (FG290.) separately.

Stiffener is not needed.

Surface has center cutout (CC) option for Logic Mini unit. Order Logic mini (Y1414.) and grommet (Y1412.1) separately.

For cable management with optional Logic, cable management channel (FT19C.o8) can be used. Order separately.

For use with Canvas Office Landscape®, specify 1 1/4" thick top.

Order the following support products separately:

- Surface support, post leg (FG2B3.)
- Chase to surface tether brackets (FG290.)

For additional finish options, see Vary Easy Program in appendices.

For support and planning information, see planning guide.

**Dimensions**

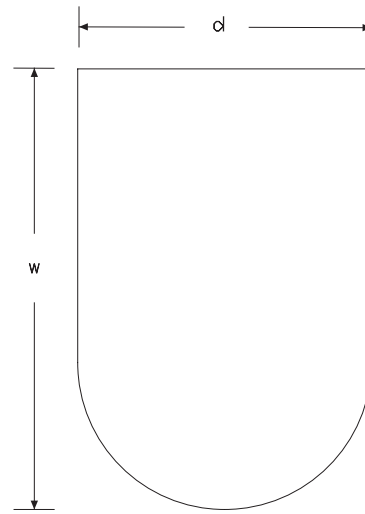

Laminate, Veneer

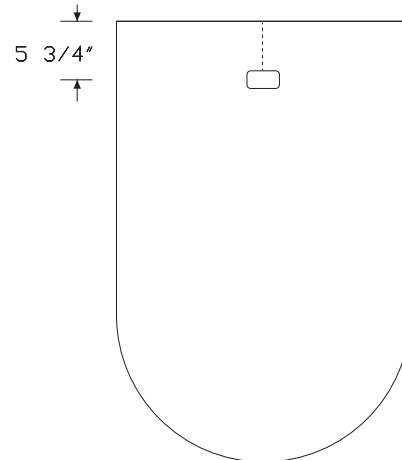
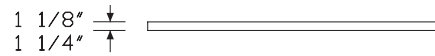

Cutout Location

# Peninsula Surface, Round End

continued

## Specification Information

Step 1.

**FG**

Step 2. Edge

**S35.** squared-edge

Step 3. Depth

**36** 36" deep

**42** 42" deep

Step 4. Width

**48** 48" wide

**54** 54" wide

Step 5. Surface Material

**L** laminate top/thermoplastic edge

**W** veneer top/veneer edge **A**

Step 6. Top Thickness

**04** 1<sup>1</sup>/<sub>4</sub>" thick

**08** 1<sup>1</sup>/<sub>8</sub>" thick

Prices for Steps 1-6.

	<b>L04</b>	<b>L08</b>	<b>W04</b>	<b>W08</b>
<b>FGS35. 36 48</b>	\$598	654	999	1054
<b>54</b>	\$750	806	1253	1308
<b>42 48</b>	\$669	725	1117	1173
<b>54</b>	\$892	948	1490	1545

Step 7.

Top Finish

*For laminate top/thermoplastic edge (L)*

<b>76</b>	light brown walnut	+\$0
<b>8Q</b>	folkstone grey	+\$0
<b>91</b>	white	+\$0
<b>98</b>	studio white	+\$0
<b>CL</b>	cool grey neutral	+\$0
<b>HF</b>	inner tone light	+\$0
<b>HM</b>	natural maple	+\$0
<b>HP</b>	light anigre	+\$0
<b>HT</b>	inner tone	+\$0
<b>HX</b>	aged cherry	+\$0
<b>HY</b>	walnut on cherry	+\$0
<b>LA</b>	light ash	+\$0
<b>LBA</b>	clear on ash	+\$0
<b>LBB</b>	oak on ash	+\$0
<b>LBC</b>	walnut on ash	+\$0
<b>LBD</b>	dark brown walnut	+\$0
<b>LBF</b>	neutral twill	+\$0
<b>LBG</b>	sarum twill	+\$0
<b>LBH</b>	earthen twill	+\$0
<b>LBJ</b>	graphite twill	+\$0
<b>LBM</b>	crisp linen	+\$0
<b>LBN</b>	classic linen	+\$0
<b>LBP</b>	casual linen	+\$0
<b>LBQ</b>	white twill	+\$0
<b>LBR</b>	phantom ecru	+\$0
<b>LBS</b>	phantom cocoa	+\$0
<b>LBU</b>	medium matte walnut	+\$0
<b>LBV</b>	warm grey teak	+\$0
<b>LT</b>	light tone	+\$0
<b>LU</b>	soft white	+\$0
<b>MT</b>	medium tone	+\$0
<b>WL</b>	sandstone	+\$0
<b>WN</b>	warm grey neutral	+\$0

Top Finish

*For laminate top/thermoplastic edge (L)*

<b>OG</b>	honey maple	+\$0
-----------	-------------	------

# Peninsula Surface, Round End

continued

Canvas Vista™ Work Surfaces

Top/Edge Finish		
<i>For veneer top/veneer edge (W)</i>		
<b>2U</b>	light brown walnut	+\$85
<b>40</b>	dark brown walnut	+\$85
<b>ED</b>	aged cherry	+\$85
<b>EK</b>	medium red walnut	+\$85
<b>ET</b>	clear on ash	+\$85
<b>EU</b>	oak on ash	+\$85
<b>EV</b>	walnut on ash	+\$85
<b>EW</b>	medium matte walnut	+\$85
<b>UL</b>	natural maple	+\$85
<b>UX</b>	walnut on cherry	+\$85

Step 8. Edge Finish		
<i>For laminate top/thermoplastic edge (L)</i>		
<b>76</b>	light brown walnut	+\$0
<b>8Q</b>	folkstone grey	+\$0
<b>91</b>	white	+\$0
<b>98</b>	studio white	+\$0
<b>BU</b>	black umber	+\$0
<b>CL</b>	cool grey neutral	+\$0
<b>HF</b>	inner tone light	+\$0
<b>HM</b>	natural maple	+\$0
<b>HP</b>	light anigre	+\$0
<b>HT</b>	inner tone	+\$0
<b>HX</b>	aged cherry	+\$0
<b>HY</b>	walnut on cherry	+\$0
<b>LA</b>	light ash	+\$0
<b>LBA</b>	clear on ash	+\$0
<b>LBB</b>	oak on ash	+\$0
<b>LBC</b>	walnut on ash	+\$0
<b>LBD</b>	dark brown walnut	+\$0
<b>LBF</b>	neutral twill	+\$0
<b>LBG</b>	sarum twill	+\$0
<b>LBH</b>	earthen twill	+\$0
<b>LBJ</b>	graphite twill	+\$0
<b>LBK</b>	pewter mesh	+\$0
<b>LBL</b>	steel mesh	+\$0
<b>LBM</b>	crisp linen	+\$0
<b>LBN</b>	classic linen	+\$0
<b>LBP</b>	casual linen	+\$0
<b>LBQ</b>	white twill	+\$0
<b>LBR</b>	phantom ecru	+\$0
<b>LBS</b>	phantom cocoa	+\$0
<b>LBU</b>	medium matte walnut	+\$0
<b>LBV</b>	warm grey teak	+\$0
<b>LU</b>	soft white	+\$0

<b>MT</b>	medium tone	+\$0
<b>WL</b>	sandstone	+\$0
<b>WN</b>	warm grey neutral	+\$0
<b>OG</b>	honey maple	+\$0

Step 9. Power Access Cutout		
<b>CC</b>	center cutout for Logic Mini -	+\$55
<b>NC</b>	no cutout	+\$0

# Café Rectangle

FGS34.

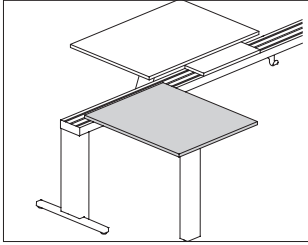

### Product Information

#### Description

This squared-edge café surface attaches to the Canvas Vista™ chase with a pair of tether brackets and requires a surface support leg. It has a laminate top with thermoplastic edge, laminate top with thermoplastic backed plywood edge, or veneer top and edge. Laminate and veneer surfaces are 1/8" thick or 1/4" thick. Surface is available with or without a cutout for the Logic Mini unit. Surface cannot stand alone. When tethered to the chase there is a 1" gap between the work surface and the top of the chase to allow for standard plug head and cord passage.

#### Notes

For attachment to the Vista chase, order tether brackets (FG290.) separately.

For use with Canvas Office Landscape®, specify 1/4" thick top.

Surface has center cutout (CC) option for Logic Mini unit. Order Logic mini (Y1414.) and grommet (Y1412.) separately.

For cable management with optional Logic, cable management channel (FT19C.o8) can be used. Order separately.

Stiffener (FG696.39) is required for the 54"-wide surface. Surfaces 36", 42"- and 48"-wide do not require a stiffener. For additional information, see Vista planning guide for specific stiffener guidelines.

Order the following support products separately:

- Surface support, A-leg (FG2B1.)
- Surface support, T-leg (FG2B2.)
- Surface support, post leg (FG2B3.)
- Stiffener (FG696.)
- Chase to surface tether brackets (FG290.)

For additional finish options, see Vary Easy Program in appendices.

### Dimensions

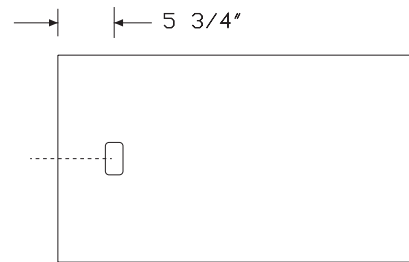
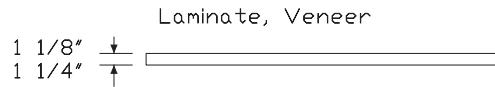
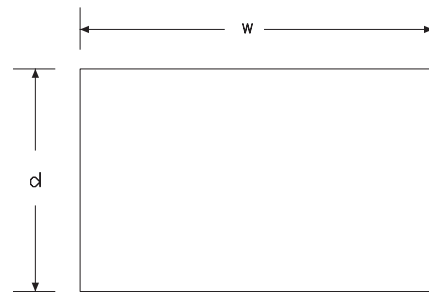

Cutout Location

**Specification Information**

Step 1.

**FG**

Step 2. Edge

**S34.** squared-edge

Step 3. Depth

**21** 21" deep

**42** 42" deep

Step 4. Width

**36** 36" wide

**42** 42" wide

**48** 48" wide

**54** 54" wide

Step 5. Surface Material

**L** laminate top/thermoplastic edge

**U** laminate top/universal edge

**W** veneer top/veneer edge A

Step 6. Top Thickness

**04** 1¼" thick

**08** 1⅝" thick

Prices for Steps 1-6.

	<b>L04</b>	<b>L08</b>	<b>U04</b>	<b>U08</b>	<b>W04</b>	<b>W08</b>
<b>FGS34. 21 36</b>	\$243	299	243	299	542	598
<b>42</b>	\$246	302	246	302	576	631
<b>48</b>	\$251	307	251	307	608	664
<b>54</b>	\$303	359	303	359	704	760
<b>42 36</b>	\$522	578	522	578	1079	1135
<b>42</b>	\$568	623	568	623	1203	1259
<b>48</b>	\$613	669	613	669	1327	1382
<b>54</b>	\$659	714	659	714	1449	1505

Step 7.

Top Finish

*For laminate top/thermoplastic edge (L) or laminate top/universal edge (U)*

<b>76</b>	light brown walnut	+\$0
<b>8Q</b>	folkstone grey	+\$0
<b>91</b>	white	+\$0
<b>98</b>	studio white	+\$0
<b>CL</b>	cool grey neutral	+\$0
<b>HF</b>	inner tone light	+\$0
<b>HM</b>	natural maple	+\$0
<b>HP</b>	light anigre	+\$0
<b>HT</b>	inner tone	+\$0
<b>HX</b>	aged cherry	+\$0
<b>HY</b>	walnut on cherry	+\$0
<b>LA</b>	light ash	+\$0
<b>LBA</b>	clear on ash	+\$0
<b>LBB</b>	oak on ash	+\$0
<b>LBC</b>	walnut on ash	+\$0
<b>LBD</b>	dark brown walnut	+\$0
<b>LBF</b>	neutral twill	+\$0
<b>LBG</b>	sarum twill	+\$0
<b>LBH</b>	earthen twill	+\$0
<b>LBJ</b>	graphite twill	+\$0
<b>LBM</b>	crisp linen	+\$0
<b>LBN</b>	classic linen	+\$0
<b>LBP</b>	casual linen	+\$0
<b>LBQ</b>	white twill	+\$0
<b>LBR</b>	phantom ecru	+\$0
<b>LBS</b>	phantom cocoa	+\$0
<b>LBU</b>	medium matte walnut	+\$0
<b>LBV</b>	warm grey teak	+\$0
<b>LT</b>	light tone	+\$0
<b>LU</b>	soft white	+\$0
<b>MT</b>	medium tone	+\$0
<b>WL</b>	sandstone	+\$0
<b>WN</b>	warm grey neutral	+\$0

## Café Rectangle *continued*

### Top/Edge Finish: Wood Veneer

#### For veneer top/veneer edge (W)

<b>2U</b>	light brown walnut	+\$85
<b>40</b>	dark brown walnut	+\$85
<b>ED</b>	aged cherry	+\$85
<b>EK</b>	medium red walnut	+\$85
<b>ET</b>	clear on ash	+\$85
<b>EU</b>	oak on ash	+\$85
<b>EV</b>	walnut on ash	+\$85
<b>EW</b>	medium matte walnut	+\$85
<b>UL</b>	natural maple	+\$85
<b>UX</b>	walnut on cherry	+\$85

### Step 8. Edge Finish

#### For laminate top/thermoplastic edge (L)

<b>76</b>	light brown walnut	+\$0
<b>8Q</b>	folkstone grey	+\$0
<b>91</b>	white	+\$0
<b>98</b>	studio white	+\$0
<b>BU</b>	black umber	+\$0
<b>CL</b>	cool grey neutral	+\$0
<b>HF</b>	inner tone light	+\$0
<b>HM</b>	natural maple	+\$0
<b>HP</b>	light anigre	+\$0
<b>HT</b>	inner tone	+\$0
<b>HX</b>	aged cherry	+\$0
<b>HY</b>	walnut on cherry	+\$0
<b>LA</b>	light ash	+\$0
<b>LBA</b>	clear on ash	+\$0
<b>LBB</b>	oak on ash	+\$0
<b>LBC</b>	walnut on ash	+\$0
<b>LBD</b>	dark brown walnut	+\$0
<b>LBF</b>	neutral twill	+\$0
<b>LBG</b>	sarum twill	+\$0
<b>LBH</b>	earthen twill	+\$0
<b>LBJ</b>	graphite twill	+\$0
<b>LBK</b>	pewter mesh	+\$0
<b>LBL</b>	steel mesh	+\$0
<b>LBM</b>	crisp linen	+\$0
<b>LBN</b>	classic linen	+\$0
<b>LBP</b>	casual linen	+\$0
<b>LBQ</b>	white twill	+\$0
<b>LBR</b>	phantom ecru	+\$0
<b>LBS</b>	phantom cocoa	+\$0
<b>LBU</b>	medium matte walnut	+\$0
<b>LBV</b>	warm grey teak	+\$0

<b>LU</b>	soft white	+\$0
<b>MT</b>	medium tone	+\$0
<b>WL</b>	sandstone	+\$0
<b>WN</b>	warm grey neutral	+\$0

#### For laminate top/universal edge (U)

<b>PLY</b>	plywood edge	+\$50
------------	--------------	-------

### Step 9. Power Access Cutout

<b>NC</b>	no cutout	+\$0
<b>CC</b>	center cutout for Logic Mini -	+\$55

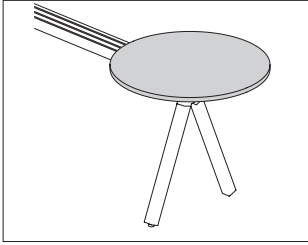

Canvas Vista™ Work Surfaces

**Product Information**

**Description**  
 This surface attaches to the top of the Canvas Vista™ chase with tether brackets to provide an area for collaboration. It has a laminate top with thermoplastic edge or veneer top and edge. Laminate and veneer surfaces are 1 1/8" or 1 1/4" thick.

**Notes**  
 Requires 2 pair of tether brackets (FG290.) for attachment to the chase.  
 Café round surface can be mounted anywhere along the chase while adhering to support rules.  
 A structural support (FG11A., FG119.) must be no more than 1' from the round surface.  
 For proper support information, see planning guide.  
 For additional product options, see Vary Easy Program in appendices.

**Dimensions**

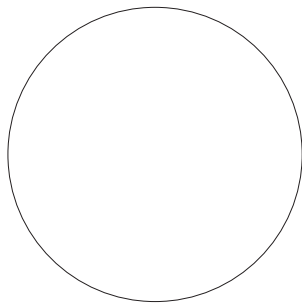
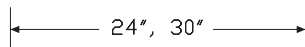

Laminate, Veneer



**Specification Information**

**Step 1.**

**FG**

**Step 2. Edge**

**S16.** squared-edge

**Step 3. Diameter**

**24** 24" diameter

**30** 30" diameter

**Step 4. Surface Material**

**L** laminate top/thermoplastic edge

**W** veneer top/veneer edge **A**

**Step 5. Top Thickness**

**04** 1 1/4" thick

**08** 1 1/8" thick

**Prices for Steps 1-5.**

	<b>04</b>	<b>08</b>
<b>FGS16. 24 L</b>	\$355	410
<b>W</b>	\$507	562
<b>30 L</b>	\$405	461
<b>W</b>	\$709	765

Step 6.

Top Finish

*For laminate top/thermoplastic edge (L)*

<b>76</b>	light brown walnut	+\$0
<b>8Q</b>	folkstone grey	+\$0
<b>91</b>	white	+\$0
<b>98</b>	studio white	+\$0
<b>CL</b>	cool grey neutral	+\$0
<b>HF</b>	inner tone light	+\$0
<b>HM</b>	natural maple	+\$0
<b>HP</b>	light anigre	+\$0
<b>HT</b>	inner tone	+\$0
<b>HX</b>	aged cherry	+\$0
<b>HY</b>	walnut on cherry	+\$0
<b>LA</b>	light ash	+\$0
<b>LBA</b>	clear on ash	+\$0
<b>LBB</b>	oak on ash	+\$0
<b>LBC</b>	walnut on ash	+\$0
<b>LBD</b>	dark brown walnut	+\$0
<b>LBF</b>	neutral twill	+\$0
<b>LBG</b>	sarum twill	+\$0
<b>LBH</b>	earthen twill	+\$0
<b>LBJ</b>	graphite twill	+\$0
<b>LBM</b>	crisp linen	+\$0
<b>LBN</b>	classic linen	+\$0
<b>LBP</b>	casual linen	+\$0
<b>LBQ</b>	white twill	+\$0
<b>LBR</b>	phantom ecru	+\$0
<b>LBS</b>	phantom cocoa	+\$0
<b>LBU</b>	medium matte walnut	+\$0
<b>LBV</b>	warm grey teak	+\$0
<b>LT</b>	light tone	+\$0
<b>LU</b>	soft white	+\$0
<b>MT</b>	medium tone	+\$0
<b>WL</b>	sandstone	+\$0
<b>WN</b>	warm grey neutral	+\$0

Top/Edge Finish

*For veneer top/veneer edge (W)*

<b>2U</b>	light brown walnut	+\$60
<b>40</b>	dark brown walnut	+\$60
<b>ED</b>	aged cherry	+\$60
<b>EK</b>	medium red walnut	+\$60
<b>ET</b>	clear on ash	+\$60
<b>EU</b>	oak on ash	+\$60
<b>EV</b>	walnut on ash	+\$60
<b>EW</b>	medium matte walnut	+\$60
<b>UL</b>	natural maple	+\$60
<b>UX</b>	walnut on cherry	+\$60

Step 7. Edge Finish

*For laminate top/thermoplastic edge (L)*

<b>28</b>	canyon	+\$0
<b>29</b>	misted	+\$0
<b>38</b>	twilight	+\$0
<b>39</b>	desert	+\$0
<b>76</b>	light brown walnut	+\$0
<b>8Q</b>	folkstone grey	+\$0
<b>91</b>	white	+\$0
<b>98</b>	studio white	+\$0
<b>BU</b>	black umber	+\$0
<b>CL</b>	cool grey neutral	+\$0
<b>CM</b>	cinnamon	+\$0
<b>CO</b>	chamomile	+\$0
<b>G2</b>	graphite satin	+\$0
<b>HF</b>	inner tone light	+\$0
<b>HM</b>	natural maple	+\$0
<b>HP</b>	light anigre	+\$0
<b>HT</b>	inner tone	+\$0
<b>HX</b>	aged cherry	+\$0
<b>HY</b>	walnut on cherry	+\$0
<b>LA</b>	light ash	+\$0
<b>LBA</b>	clear on ash	+\$0
<b>LBB</b>	oak on ash	+\$0
<b>LBC</b>	walnut on ash	+\$0
<b>LBD</b>	dark brown walnut	+\$0
<b>LBF</b>	neutral twill	+\$0
<b>LBG</b>	sarum twill	+\$0
<b>LBH</b>	earthen twill	+\$0
<b>LBJ</b>	graphite twill	+\$0
<b>LBK</b>	pewter mesh	+\$0
<b>LBL</b>	steel mesh	+\$0
<b>LBM</b>	crisp linen	+\$0
<b>LBN</b>	classic linen	+\$0

Café Round *continued*

Canvas Vista™ Work Surfaces

<b>LBP</b>	casual linen	+\$0
<b>LBQ</b>	white twill	+\$0
<b>LBR</b>	phantom ecru	+\$0
<b>LBS</b>	phantom cocoa	+\$0
<b>LBU</b>	medium matte walnut	+\$0
<b>LBV</b>	warm grey teak	+\$0
<b>LT</b>	light tone	+\$0
<b>LU</b>	soft white	+\$0
<b>MT</b>	medium tone	+\$0
<b>N3</b>	cool grey	+\$0
<b>SG</b>	slate grey	+\$0
<b>WA</b>	wheat	+\$0
<b>WL</b>	sandstone	+\$0
<b>WN</b>	warm grey neutral	+\$0

# Chase to Surface Tether Brackets FG290.

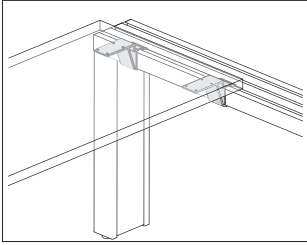

## Product Information

### Description

These brackets attach a surface to a chase in a perpendicular or parallel application or a peninsula surface perpendicular to the chase. Sold as a pair. Attachment hardware included.

### Notes

Tether brackets alone cannot support a surface. Tethers must be used with a surface support leg (FG2B1., FG2B2., FG2B3.), ordered separately. Tether placement is 3 1/2" from surface edge to tether edge on both sides of work surface.

### Dimensions

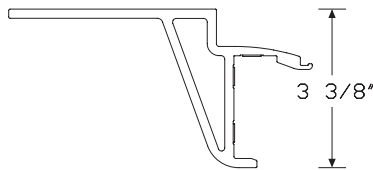
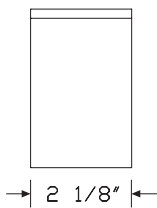
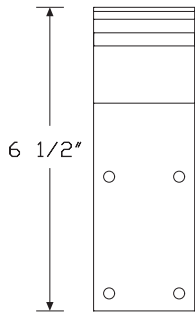

## Specification Information

### Step 1.

**FG290.** \$213

### Step 2. Finish

<b>8Q</b>	folkstone grey	+\$0
<b>91</b>	white	+\$0
<b>98</b>	studio white	+\$0
<b>BK</b>	black	+\$0
<b>CL</b>	cool grey neutral	+\$0
<b>CN</b>	metallic champagne	+\$0
<b>EH</b>	metallic bronze	+\$0
<b>G1</b>	graphite	+\$0
<b>MS</b>	metallic silver	+\$0
<b>WL</b>	sandstone	+\$0
<b>WN</b>	warm grey neutral	+\$0

# Stiffener

FG696.

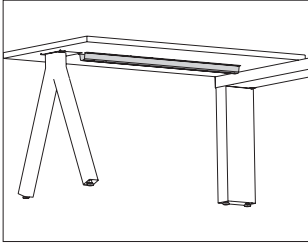

Canvas Vista™ Work Surfaces

## Product Information

**Description**  
 This stiffener adds additional stiffness to a Canvas Vista™ freestanding surface, Vista chase-attached surface or Vista peninsula surface.  
 Attachment hardware included.

## Notes

Stiffener extends  $1\frac{1}{4}$ " below the surface.  
 Common stiffener applications include the following. See planning guide for more applications.  
 Stiffener Width—Leg Placement—Surface Width  
 34"—2 legs outbound—48"  
 34"—1 leg inset, 1 leg outbound—54"  
 34"—2 legs inset—60"  
 39"—2 legs outbound—54"  
 39"—2 legs inset—66"  
 43"—2 legs outbound—60"  
 43"—1 leg inset, 1 leg outbound—60"  
 43"—2 legs inset—72"  
 48"—2 legs outbound—66"  
 48"—1 leg inset, 1 leg outbound—66", 72"  
 57"—2 legs outbound—72"

## Dimensions

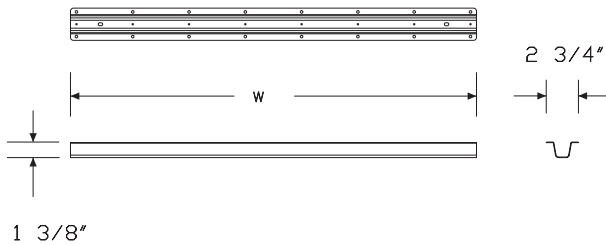

## Specification Information

Step 1.

**FG696.**

## Step 2. Width

<b>34</b>	33 <sup>7</sup> / <sub>8</sub> " wide
<b>39</b>	38 <sup>5</sup> / <sub>8</sub> " wide
<b>43</b>	43 <sup>1</sup> / <sub>4</sub> " wide
<b>48</b>	48" wide
<b>57</b>	57 <sup>3</sup> / <sub>8</sub> " wide

## Prices for Steps 1-2.

<b>FG696. 34</b>	\$72
<b>39</b>	\$72
<b>43</b>	\$73
<b>48</b>	\$73
<b>57</b>	\$74

# Surface Support, A-Leg

FG2B1.

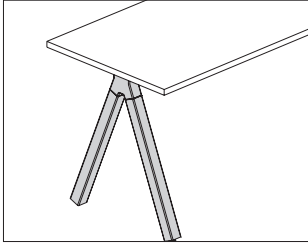

### Product Information

#### Description

This A-leg provides support for a chase-attached work surface, peninsula surface or café surface. It can also support a freestanding rectangular work surface. Fixed-height leg provides 2" of leveling adjustment. Attachment hardware included.

#### Notes

To support a chase-attached work surface, café surface or peninsula surface, tether brackets (FG290.) are required to support opposite end of surface. Order separately.

A-leg can support 24"- and 30"-deep freestanding rectangular work surfaces (FGS10.).

For additional support information, see planning guide.

#### Dimensions

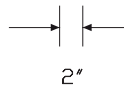
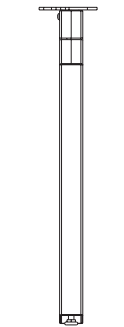
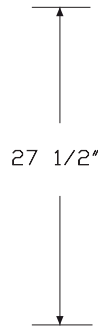
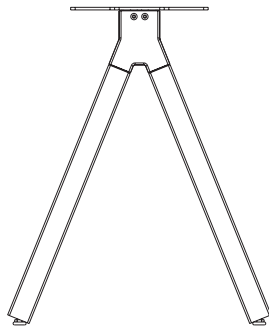
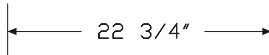
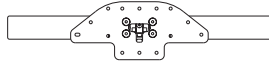

### Specification Information

#### Step 1.

**FG2B1.** \$574

#### Step 2. Finish

#### Smooth Paint

<b>8Q</b>	folkstone grey	+\$0
<b>91</b>	white	+\$0
<b>98</b>	studio white	+\$0
<b>CL</b>	cool grey neutral	+\$0
<b>WL</b>	sandstone	+\$0
<b>WN</b>	warm grey neutral	+\$0

#### Metallic Paint

<b>CN</b>	metallic champagne	+\$0
<b>EH</b>	metallic bronze	+\$0
<b>MS</b>	metallic silver	+\$0

#### Sand Texture Paint

<b>BK</b>	black	+\$0
<b>G1</b>	graphite	+\$0

# Surface Support, T Leg

FG2B2.

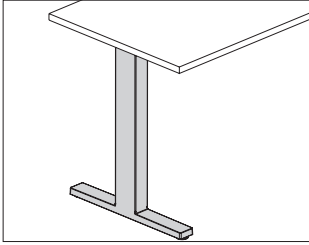

## Product Information

### Description

This T-leg provides support for a chase-attached work surface, peninsula surface or café surface. It can also support a freestanding rectangular work surface. Fixed-height leg provides 2" of leveling adjustment. Attachment hardware included.

### Notes

To support a chase-attached work surface, café surface or peninsula surface, tether brackets (FG290.) are required to support opposite end of surface. Order separately.

T-leg can support 24"- and 30"-deep freestanding rectangular work surfaces (FGS10.).

For additional support information, see planning guide.

## Dimensions

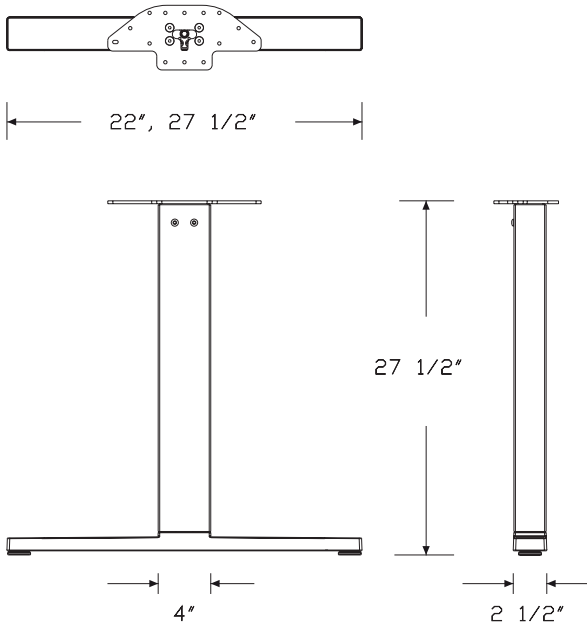

## Specification Information

### Step 1.

**FG2B2.**

### Step 2. Depth

<b>24</b>	24" deep
<b>30</b>	30" deep

### Prices for Steps 1-2.

<b>FG2B2. 24</b>	\$421
<b>30</b>	\$430

### Step 3. Finish

#### Smooth Paint

<b>8Q</b>	folkstone grey	+\$0
<b>91</b>	white	+\$0
<b>98</b>	studio white	+\$0
<b>CL</b>	cool grey neutral	+\$0
<b>WL</b>	sandstone	+\$0
<b>WN</b>	warm grey neutral	+\$0

#### Metallic Paint

<b>CN</b>	metallic champagne	+\$0
<b>EH</b>	metallic bronze	+\$0
<b>MS</b>	metallic silver	+\$0

#### Sand Texture Paint

<b>BK</b>	black	+\$0
<b>G1</b>	graphite	+\$0

# Surface Support, Post Leg

FG2B3.

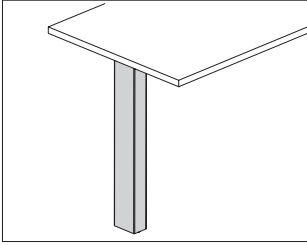

## Product Information

### Description

This post leg provides support for a chase-attached work surface, peninsula surface or café surface. Fixed-height leg provides 2" of leveling adjustment. Attachment hardware included.

### Notes

To support a chase-attached work surface, café surface or peninsula surface, tether brackets (FG290.) are required to support opposite end of surface. Order separately.

Shared post leg (FG2B3.2) supports 2 parallel surfaces in a benching application.

For additional support information, see planning guide.

## Dimensions

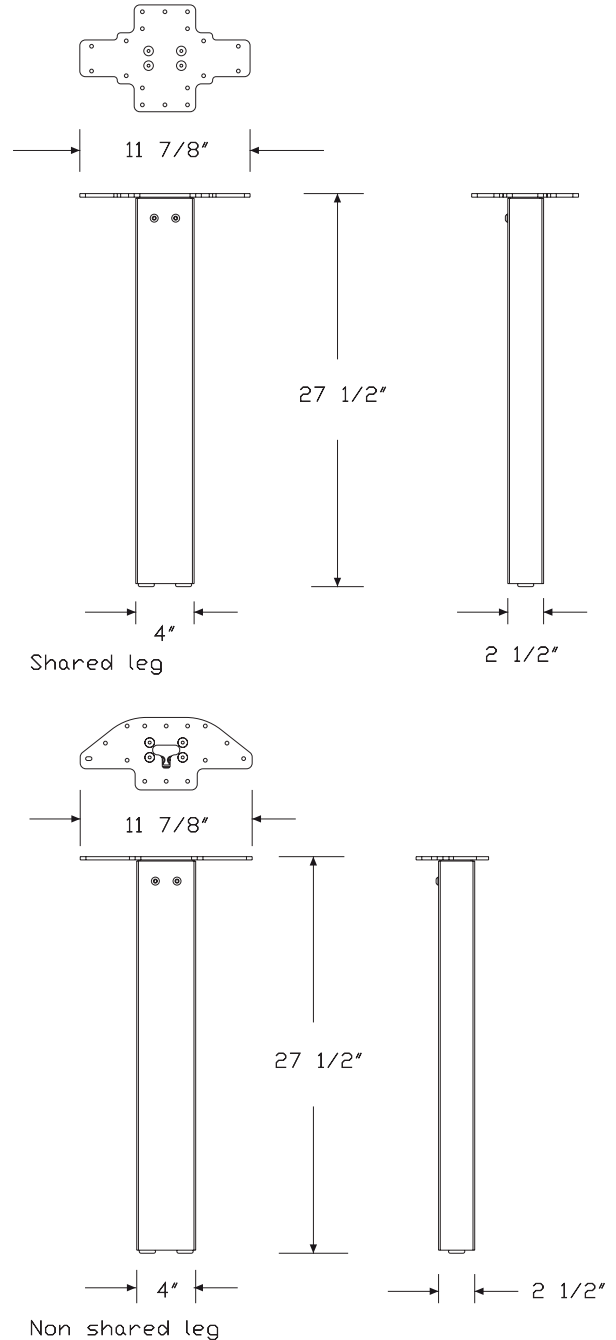

Canvas Vista™ Work Surfaces

# Surface Support, Post Leg *continued*

## Specification Information

Step 1.

**FG2B3.**

Step 2. Application

- 1 non-shared (one surface)
- 2 shared (between two surfaces)

Prices for Steps 1-2.

<b>FG2B3. 1</b>	\$389
2	\$389

Step 3. Finish

Smooth Paint

<b>8Q</b>	folkstone grey	+\$0
<b>91</b>	white	+\$0
<b>98</b>	studio white	+\$0
<b>CL</b>	cool grey neutral	+\$0
<b>WL</b>	sandstone	+\$0
<b>WN</b>	warm grey neutral	+\$0

Metallic Paint

<b>CN</b>	metallic champagne	+\$0
<b>EH</b>	metallic bronze	+\$0
<b>MS</b>	metallic silver	+\$0

Sand Texture Paint

<b>BK</b>	black	+\$0
<b>G1</b>	graphite	+\$0

# Open Frame Screen, Chase Attached

FG112.

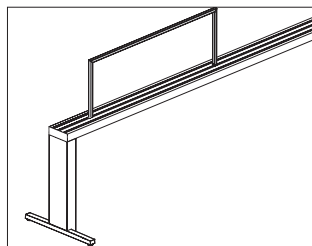

### Product Information

#### Description

This steel tube screen attaches anywhere along the top of a Canvas Vista™ chase to create layering and a sense of boundary without an enclosed barrier on top of the chase. Attachment hardware included.

#### Notes

Screen can be placed in any of the 3 tracks on top of chase.

Actual screen height is 14.63"; actual width is 42".

A movable insert (FG430.) can snap onto open frame screen and is user movable. Order separately.

Steel frame provides magnetic ability.

For proper support information, see planning guide.

#### Dimensions

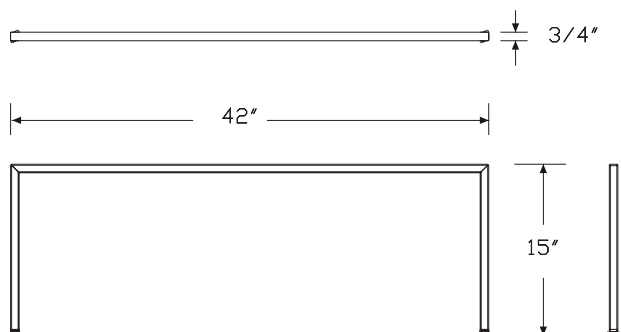

### Specification Information

#### Step 1.

**FG112.**

#### Step 2. Height

**15** 15" high (to reach 42" datum)

#### Step 3. Width

**42** 42" wide

#### Prices for Steps 1-3.

	<b>42</b>
<b>FG112. 15</b>	\$429

#### Step 4. Screen Finish

##### Smooth Paint

<b>91</b>	white	+\$0
<b>98</b>	studio white	+\$0
<b>SNA</b>	satin aluminum	+\$0
<b>SNC</b>	satin carbon	+\$0

##### Metallic Paint

<b>CN</b>	metallic champagne	+\$0
<b>MS</b>	metallic silver	+\$0

##### Sand Texture Paint

<b>BK</b>	black	+\$0
<b>G1</b>	graphite	+\$0

# Display Unit, Chase Attached

FG111.

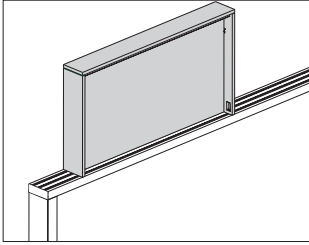

## Product Information

### Description

This screen has a frame in laminate or veneer that attaches to the top of the Canvas Vista™ chase to create boundary and collaborative areas. Center panel is available in laminate or veneer and accepts attachment of monitors and/or optional infills.

### Notes

Screen actual height is 25.64" with frame.

Frame is 6" deep and will encompass all 3 tracks on top of chase.

Grain direction on outer frame is vertical on each side and horizontal along the top. Grain direction on center panel must be specified.

A monitor can be mounted to either or both sides of display unit center panel. When using infill (FG491.), infill must be field cut for monitor installation.

Order optional fabric or marker board infill (FG491.xxxxF, FG491.xxxxM) separately.

The movable insert (FG430.) can attach horizontally to top rail of display unit. Order movable insert separately.

For proper support information, see planning guide.

### Dimensions

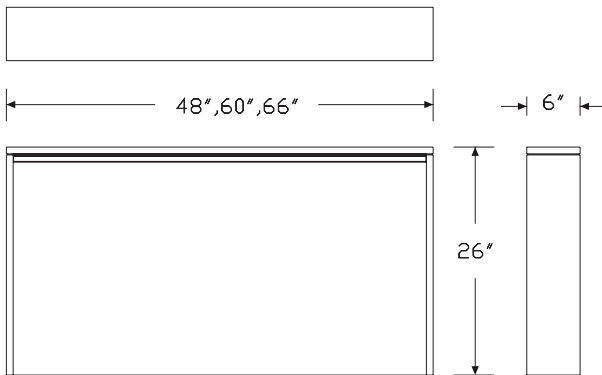

## Specification Information

### Step 1.

**FG111.**

### Step 2. Height

**26** 26" high (to reach 53" datum)

### Step 3. Width

**48** 48" wide

**60** 60" wide

**66** 66" wide

### Step 4. Frame

**L** laminate frame

**W** veneer frame

### Step 5. Center Panel

**L** laminate center panel

**W** veneer center panel **A**

### Prices for Steps 1-5.

		LL	LW	WL	WW
<b>FG111. 26</b>	<b>48</b>	\$1530	2159	2321	2990
	<b>60</b>	\$1610	2224	2385	3142
	<b>66</b>	\$1656	2290	2447	3294

### Step 6. Grain Direction for Center Panel

<b>HRG</b>	horizontal grain	+\$0
<b>VTG</b>	vertical grain	+\$0

### For 66" wide (66) with laminate center panel (L)

<b>HRG</b>	horizontal grain	+\$0
------------	------------------	------

# Display Unit, Chase Attached

continued

## Step 7. Frame Finish

### For laminate frame (L)

<b>76</b>	light brown walnut	+\$0
<b>8Q</b>	folkstone grey	+\$0
<b>91</b>	white	+\$0
<b>98</b>	studio white	+\$0
<b>CL</b>	cool grey neutral	+\$0
<b>G1</b>	graphite	+\$0
<b>HM</b>	natural maple	+\$0
<b>HP</b>	light anigre	+\$0
<b>HX</b>	aged cherry	+\$0
<b>HY</b>	walnut on cherry	+\$0
<b>LA</b>	light ash	+\$0
<b>LBA</b>	clear on ash	+\$0
<b>LBB</b>	oak on ash	+\$0
<b>LBC</b>	walnut on ash	+\$0
<b>LBD</b>	dark brown walnut	+\$0
<b>LBF</b>	neutral twill	+\$0
<b>LBG</b>	sarum twill	+\$0
<b>LBH</b>	earthen twill	+\$0
<b>LBJ</b>	graphite twill	+\$0
<b>LBK</b>	pewter mesh	+\$0
<b>LBL</b>	steel mesh	+\$0
<b>LBM</b>	crisp linen	+\$0
<b>LBN</b>	classic linen	+\$0
<b>LBP</b>	casual linen	+\$0
<b>LBQ</b>	white twill	+\$0
<b>LBR</b>	phantom ecru	+\$0
<b>LBS</b>	phantom cocoa	+\$0
<b>LBU</b>	medium matte walnut	+\$0
<b>LBV</b>	warm grey teak	+\$0
<b>LU</b>	soft white	+\$0
<b>WL</b>	sandstone	+\$0
<b>WN</b>	warm grey neutral	+\$0

### For veneer frame (W)

<b>2U</b>	light brown walnut	+\$0
<b>40</b>	dark brown walnut	+\$0
<b>ED</b>	aged cherry	+\$0
<b>EK</b>	medium red walnut	+\$0
<b>ET</b>	clear on ash	+\$0
<b>EU</b>	oak on ash	+\$0
<b>EV</b>	walnut on ash	+\$0
<b>EW</b>	medium matte walnut	+\$0
<b>UL</b>	natural maple	+\$0
<b>UX</b>	walnut on cherry	+\$0

## Step 8. Center Panel Finish

### For laminate center panel (L)

<b>LBR</b>	phantom ecru	+\$0
<b>LBS</b>	phantom cocoa	+\$0
<b>LBU</b>	medium matte walnut	+\$0
<b>LBV</b>	warm grey teak	+\$0
<b>76</b>	light brown walnut	+\$0
<b>8Q</b>	folkstone grey	+\$0
<b>91</b>	white	+\$0
<b>98</b>	studio white	+\$0
<b>CL</b>	cool grey neutral	+\$0
<b>G1</b>	graphite	+\$0
<b>HM</b>	natural maple	+\$0
<b>HP</b>	light anigre	+\$0
<b>HX</b>	aged cherry	+\$0
<b>HY</b>	walnut on cherry	+\$0
<b>LA</b>	light ash	+\$0
<b>LBA</b>	clear on ash	+\$0
<b>LBB</b>	oak on ash	+\$0
<b>LBC</b>	walnut on ash	+\$0
<b>LBD</b>	dark brown walnut	+\$0
<b>LBF</b>	neutral twill	+\$0
<b>LBG</b>	sarum twill	+\$0
<b>LBH</b>	earthen twill	+\$0
<b>LBJ</b>	graphite twill	+\$0
<b>LBK</b>	pewter mesh	+\$0
<b>LBL</b>	steel mesh	+\$0
<b>LBM</b>	crisp linen	+\$0
<b>LBN</b>	classic linen	+\$0
<b>LBP</b>	casual linen	+\$0
<b>LBQ</b>	white twill	+\$0
<b>LU</b>	soft white	+\$0
<b>WL</b>	sandstone	+\$0
<b>WN</b>	warm grey neutral	+\$0

### For veneer center panel (W)

<b>2U</b>	light brown walnut	+\$0
<b>40</b>	dark brown walnut	+\$0
<b>ED</b>	aged cherry	+\$0
<b>EK</b>	medium red walnut	+\$0
<b>ET</b>	clear on ash	+\$0
<b>EU</b>	oak on ash	+\$0
<b>EV</b>	walnut on ash	+\$0
<b>EW</b>	medium matte walnut	+\$0
<b>UL</b>	natural maple	+\$0
<b>UX</b>	walnut on cherry	+\$0

Canvas Vista™ Screens - Chase Attach

# Display Unit, Chase Attached

*continued*

---

## Step 9. Top Rail and Pocket Finish

---

### Smooth Paint

---

<b>91</b>	white	+\$0
<b>98</b>	studio white	+\$0
<b>SNA</b>	satin aluminum	+\$0
<b>SNC</b>	satin carbon	+\$0

---

### Metallic Paint

---

<b>CN</b>	metallic champagne	+\$0
<b>MS</b>	metallic silver	+\$0

---

### Sand Texture Paint

---

<b>BK</b>	black	+\$0
<b>G1</b>	graphite	+\$0

---

# Infill, Display Unit

FG491.

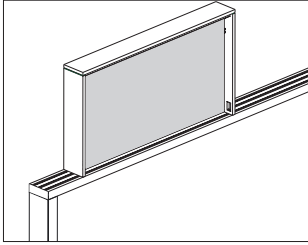

### Product Information

#### Description

This fabric or marker board infill attaches to the center panel of the display unit. Fabric is tackable and marker board is magnetic. Attachment hardware included.

#### Notes

Infill actual height is 23.92".

Specify 1 infill per side of display unit.

A monitor can be mounted to either or both sides of the display unit (FG111.) center panel. When using infill, infill must be field cut for monitor installation.

For planning information, see planning guide.

#### Dimensions

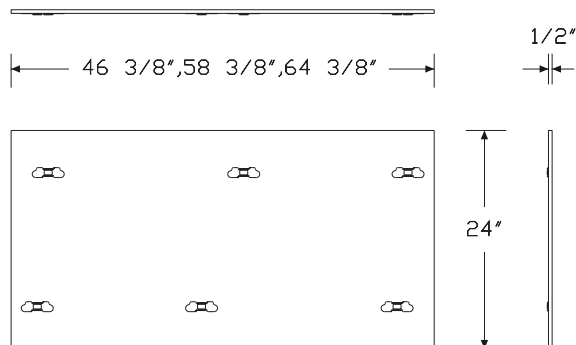

### Specification Information

#### Step 1.

**FG491.**  A

#### Step 2. Height

**26** 26" high (to reach 53" datum)  A

#### Step 3. Width

**48** 48" wide  A

**60** 60" wide  A

**66** 66" wide  A

#### Step 4. Infill Material

**F** fabric  A

**M** marker board - magnetic  A

#### Step 5. Surface Material

##### For 48" wide (48) with fabric (F)

**R** tackable fabric, horizontal  A

**T** tackable fabric  A

##### For 60" wide (60) or 66" wide (66) with fabric (F)

**R** tackable fabric, horizontal  A

#### Prices for Steps 1-5.

	FR	FT	M
<b>FG491. 26 48</b>	\$358	358	544
<b>60</b>	\$399	—	562
<b>66</b>	\$446	—	579

#### Step 6. Fabric

##### For fabric (F)

Price Category 1	+\$0
Price Category 2	+\$27
Price Category 3	+\$61
Price Category 4	+\$104
Price Category 5	+\$173
Price Category B	+\$113
Price Category C	+\$155
Price Category D	+\$196
Price Category E	+\$236
Price Category F	+\$305
Price Category G	+\$396

# Moveable Insert

FG430.

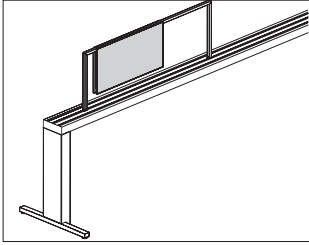

### Product Information

#### Description

This moveable insert snaps onto a chase-attached or surface-attached open frame screen to provide moderate visual privacy. It has an ABS plastic frame covered with fabric or marker board and is user movable.

#### Notes

Fabric surface and marker board are magnetic. Fabric is not tackable.  
 Movable insert works with open frame screen, chase attached (FG112.)  
 or open frame screen, surface attached (FG345.42), ordered separately.  
 Movable insert can attach horizontally to top rail of display unit (FG111.).  
 Actual insert height is 11.615"; actual width is 21.998".  
 For planning information, see planning guide.

#### Dimensions

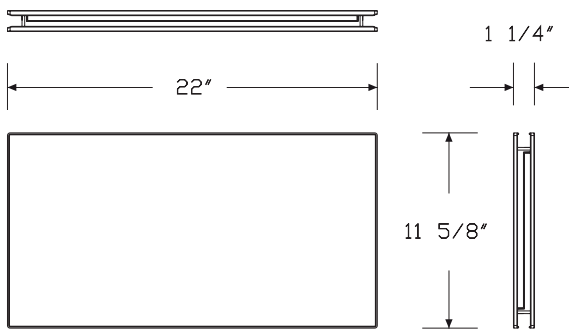

Canvas Vista™ Screens - Chase Attach

### Specification Information

#### Step 1.

**FG430.** A

#### Step 2. Height

**12** 12" high A

#### Step 3. Width

**22** 22" wide A

#### Step 4. Insert Material

**F** fabric/fabric A

**M** marker board/marker board A

**B** fabric/marker board A

#### Step 5. Surface Material

*For fabric/fabric (F) or fabric/marker board (B)*

**T** fabric A

**R** fabric, horizontal A

#### Prices for Steps 1-5.

	FT	FR	M	M	BT	BR
<b>FG430. 12 22</b>	\$360	360	329	329	345	345

#### Step 6. Insert Frame Finish

<b>98</b> studio white <span style="border: 1px solid black; padding: 0 2px;">A</span>	+\$0
<b>DCR</b> dark carbon <span style="border: 1px solid black; padding: 0 2px;">A</span>	+\$0
<b>DVP</b> dark mineral <span style="border: 1px solid black; padding: 0 2px;">A</span>	+\$0

#### Step 7. Fabric

*For fabric/fabric (F) or fabric/marker board (B)*

Price Category 1	+\$0
Price Category 2	+\$27
Price Category 3	+\$61
Price Category 4	+\$104
Price Category 5	+\$173
Price Category B	+\$113
Price Category C	+\$155
Price Category D	+\$196
Price Category E	+\$236
Price Category F	+\$305
Price Category G	+\$396

# Pari Screen, Chase Attached

FG115.

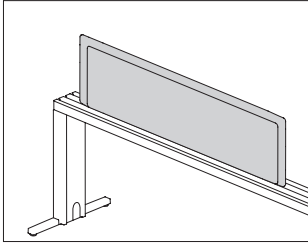

## Product Information

### Description

This tackable fabric screen attaches anywhere along the top of a Canvas Vista™ chase. It extends the overall height to provide boundary and layering with a tackable surface. Attachment hardware included.

### Notes

- Screen width does not need to match chase width.
- When using 84"-wide chase, specify 2 42"-wide screens to provide full screen coverage.
- When using 96"-wide chase, specify 2 48"-wide screens to provide full screen coverage.
- Pari screen can be placed in any of the 3 tracks on top of chase.
- Screens can mount over work surface tether brackets (FG290.) as long as screen bayonets do not collide with tether brackets.
- Screen actual heights are 14.64" (15), 18.64" (19), and 25.64" (26).
- For proper support information, see planning guide.
- Screen accepts Customer's Own Material (COM). Yardage is estimated for nondirectional 54"-wide fabrics.
- For vertical fabric direction (T):
- Height—Yardage
- 15—1.32
- 19—1.58
- 26—2.02
- For horizontal fabric direction (R), for 15" high and 19" high:
- Width—Yardage
- 24—0.95
- 30—1.13
- 36—1.32
- 42—1.51
- 48—1.70
- 60—2.08
- 66—2.27
- 72—2.46
- For horizontal fabric direction (R), for 26" high:
- Width—Yardage
- 24—1.89
- 30—2.27
- 36—2.65
- 42—3.02
- 48—3.40
- 60—4.16
- 66—4.54
- 72—4.91
- For information on multiple quantities or directional fabrics, contact COM Department. See Order Information in Appendices.

## Dimensions

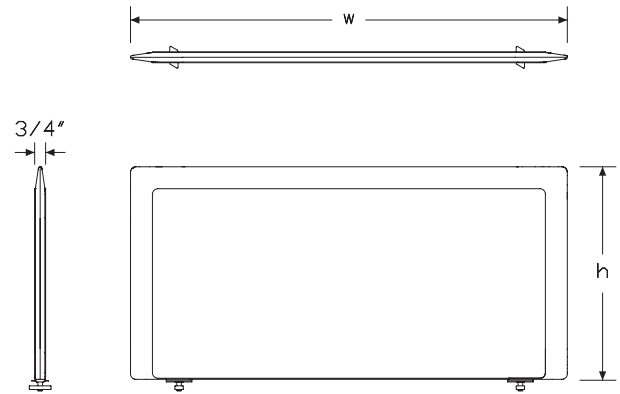

Canvas Vista™ Screens - Chase Attach

# Pari Screen, Chase Attached

continued

Canvas Vista™ Screens - Chase Attach

## Specification Information

Step 1.

**FG115.**

Step 2. Height

<b>15</b>	15" high (to reach 42" datum)
<b>19</b>	19" high (to reach 46" datum)
<b>26</b>	26" high (to reach 53" datum)

Step 3. Width

<b>24</b>	24" wide
<b>30</b>	30" wide
<b>36</b>	36" wide
<b>42</b>	42" wide
<b>48</b>	48" wide
<b>60</b>	60" wide
<b>66</b>	66" wide
<b>72</b>	72" wide

Step 4. Surface Material

For 24" wide (24), 30" wide (30), 36" wide (36), 42" wide (42), or 48" wide (48)

<b>T</b>	tackable fabric
<b>R</b>	tackable fabric, horizontal

For 60" wide (60), 66" wide (66), or 72" wide (72)

<b>R</b>	tackable fabric, horizontal
----------	-----------------------------

Prices for Steps 1-4.

	<b>T</b>	<b>R</b>
<b>FG115. 15 24</b>	\$689	689
<b>30</b>	\$740	740
<b>36</b>	\$790	790
<b>42</b>	\$841	841
<b>48</b>	\$892	892
<b>60</b>	—	\$993
<b>66</b>	—	\$1039
<b>72</b>	—	\$1089
<b>19 24</b>	\$735	735
<b>30</b>	\$785	785
<b>36</b>	\$836	836
<b>42</b>	\$887	887
<b>48</b>	\$937	937
<b>60</b>	—	\$1039
<b>66</b>	—	\$1103
<b>72</b>	—	\$1165

<b>26 24</b>	\$831	831
<b>30</b>	\$897	897
<b>36</b>	\$963	963
<b>42</b>	\$1029	1029
<b>48</b>	\$1094	1094
<b>60</b>	—	\$1226
<b>66</b>	—	\$1305
<b>72</b>	—	\$1383

Step 5. Fabric

	<b>24</b>	<b>30</b>	<b>36</b>	<b>42</b>	<b>48</b>
Price Category 1	+\$0	0	0	0	0
Price Category 2	+\$34	34	34	34	34
Price Category 3	+\$77	77	77	77	77
Price Category 4	+\$131	131	131	131	131
Price Category C	+\$195	195	195	195	195
Price Category E	+\$297	297	297	297	297
				<b>60</b>	<b>66</b>
Price Category 1			+\$0	0	0
Price Category 2			+\$57	57	57
Price Category 3			+\$130	130	130
Price Category 4			+\$224	224	224
Price Category C			+\$325	325	325
Price Category E			+\$506	506	506

# Flat Edge Screen, Chase Attached FG116.

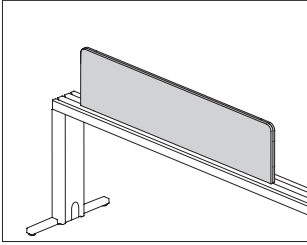

## Product Information

### Description

This tackable fabric screen attaches anywhere along the top of a Canvas Vista™ chase. It extends the overall height to provide boundary and layering with a tackable surface. Attachment hardware included.

### Notes

- Screen width does not need to match chase width.
- When using 84"-wide chase, specify 2 42"-wide screens to provide full screen coverage.
- When using 96"-wide chase, specify 2 48"-wide screens to provide full screen coverage.
- Flat-edge screen can be placed in any of the 3 tracks on top of chase.
- Screens can mount over work surface tether brackets (FG290.) as long as screen bayonets do not collide with tether brackets.
- Screen actual heights are 14.64" (15), 18.64" (19), and 25.64" (26).
- For proper support information, see planning guide.
- Screen accepts Customer's Own Material (COM). Yardage is estimated for nondirectional 54"-wide fabrics.
- For vertical fabric direction (T):
- Height—Yardage
- 15—1.32
- 19—1.58
- 26—2.02
- For horizontal fabric direction (R), for 15" high and 19" high:
- Width—Yardage
- 24—0.95
- 30—1.13
- 36—1.32
- 42—1.51
- 48—1.70
- 60—2.08
- 66—2.27
- 72—2.46
- For horizontal fabric direction (R), for 26" high:
- Width—Yardage
- 24—1.89
- 30—2.27
- 36—2.65
- 42—3.02
- 48—3.40
- 60—4.16
- 66—4.54
- 72—4.91
- For information on multiple quantities or directional fabrics, contact COM Department. See Order Information in Appendices.

## Dimensions

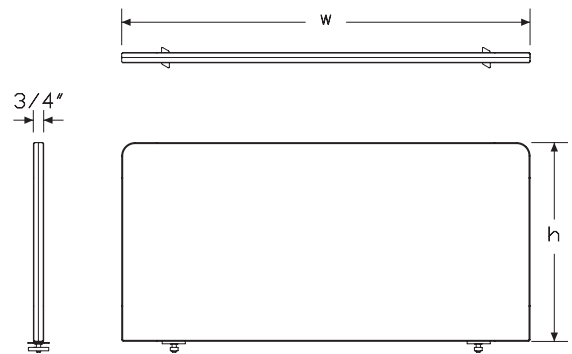

Canvas Vista™ Screens - Chase Attach

# Flat Edge Screen, Chase Attached

continued

Canvas Vista™ Screens - Chase Attach

## Specification Information

### Step 1.

**FG116.**

### Step 2. Height

<b>15</b>	15" high (to reach 42" datum)
<b>19</b>	19" high (to reach 46" datum)
<b>26</b>	26" high (to reach 53" datum)

### Step 3. Width

<b>24</b>	24" wide
<b>30</b>	30" wide
<b>36</b>	36" wide
<b>42</b>	42" wide
<b>48</b>	48" wide
<b>60</b>	60" wide
<b>66</b>	66" wide
<b>72</b>	72" wide

### Step 4. Surface Material

*For 24" wide (24), 30" wide (30), 36" wide (36), 42" wide (42), or 48" wide (48)*

<b>T</b>	tackable fabric
<b>R</b>	tackable fabric, horizontal

*For 60" wide (60), 66" wide (66), or 72" wide (72)*

<b>R</b>	tackable fabric, horizontal
----------	-----------------------------

### Prices for Steps 1-4.

	<b>T</b>	<b>R</b>
<b>FG116. 15 24</b>	\$578	578
<b>30</b>	\$623	623
<b>36</b>	\$669	669
<b>42</b>	\$714	714
<b>48</b>	\$760	760
<b>60</b>	—	\$851
<b>66</b>	—	\$897
<b>72</b>	—	\$941
<b>19 24</b>	\$593	593
<b>30</b>	\$639	639
<b>36</b>	\$686	686
<b>42</b>	\$733	733
<b>48</b>	\$778	778
<b>60</b>	—	\$872
<b>66</b>	—	\$935
<b>72</b>	—	\$999

<b>26 24</b>	\$730	730
<b>30</b>	\$798	798
<b>36</b>	\$864	864
<b>42</b>	\$932	932
<b>48</b>	\$1000	1000
<b>60</b>	—	\$1135
<b>66</b>	—	\$1239
<b>72</b>	—	\$1343

### Step 5. Fabric

*For 24" wide (24), 30" wide (30), 36" wide (36), 42" wide (42), or 48" wide (48)*

Price Category C	+\$195
Price Category 1	+\$0
Price Category 2	+\$34
Price Category 3	+\$77
Price Category 4	+\$131
Price Category E	+\$297

*For 60" wide (60), 66" wide (66), or 72" wide (72)*

Price Category 1	+\$0
Price Category 2	+\$57
Price Category 3	+\$130
Price Category 4	+\$224
Price Category E	+\$506
Price Category C	+\$325

# Laminate Screen, Chase Attached FG120.

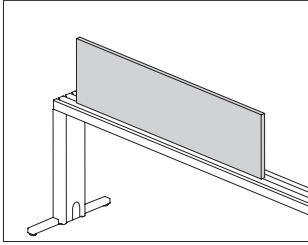

## Product Information

### Description

This laminate screen attaches anywhere along the top of a Canvas Vista™ chase. It extends the overall height to provide boundary and layering. Attachment hardware included.

### Notes

Screen width does not need to match chase width.

When using 84"-wide chase, specify 2 42"-wide screens to provide full screen coverage.

When using 96"-wide chase, specify 2 48"-wide screens to provide full screen coverage.

Laminate screen can be placed in any of the 3 tracks on top of chase.

Screens can mount over work surface tether brackets (FG290.) as long as screen bayonets do not collide with tether brackets.

Screen actual heights are 14.64" (15), 18.64" (19), and 25.64" (26).

For proper support information, see planning guide.

For additional product options, see Vary Easy Program in appendices.

## Dimensions

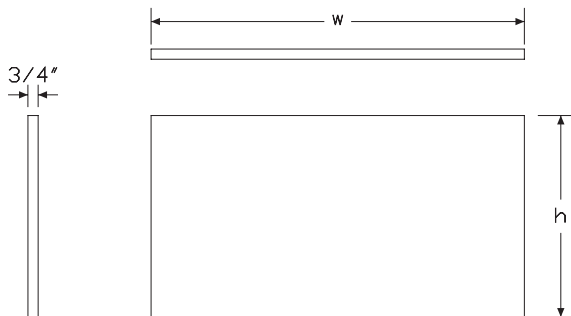

## Specification Information

### Step 1.

#### FG120.

### Step 2. Height

15	15" high (to reach 42" datum)
19	19" high (to reach 46" datum)
26	26" high (to reach 53" datum)

### Step 3. Width

24	24" wide
30	30" wide
36	36" wide
42	42" wide
48	48" wide
60	60" wide
66	66" wide
72	72" wide

### Step 4. Surface Material

L	laminate/thermoplastic edge
U	laminate/universal edge

### Prices for Steps 1-4.

		L	U
FG120.	15 24	\$431	431
	30	\$469	469
	36	\$507	507
	42	\$545	545
	48	\$583	583
	60	\$659	659
	66	\$684	684
	72	\$709	709
	19 24	\$507	507
	30	\$545	545
36	\$583	583	
42	\$621	621	
48	\$659	659	
60	\$735	735	
66	\$760	760	
72	\$785	785	

# Laminate Screen, Chase Attached

continued

Canvas Vista™ Screens - Chase Attach

<b>26</b>	<b>24</b>	\$603	603
<b>30</b>		\$640	640
<b>36</b>		\$677	677
<b>42</b>		\$714	714
<b>48</b>		\$752	752
<b>60</b>		\$826	826
<b>66</b>		\$841	841
<b>72</b>		\$856	856

## Step 5. Grain Direction

For 24" wide (24), 30" wide (30), 36" wide (36), 42" wide (42), 48" wide (48), or 60" wide (60)

<b>HRG</b>	horizontal grain	+\$0
<b>VTG</b>	vertical grain	+\$0

For 66" wide (66) or 72" wide (72)

<b>HRG</b>	horizontal grain	+\$0
------------	------------------	------

## Step 6. Surface Finish

<b>76</b>	light brown walnut	+\$0
<b>8Q</b>	folkstone grey	+\$0
<b>91</b>	white	+\$0
<b>98</b>	studio white	+\$0
<b>CL</b>	cool grey neutral	+\$0
<b>G1</b>	graphite	+\$0
<b>HM</b>	natural maple	+\$0
<b>HP</b>	light anigre	+\$0
<b>HX</b>	aged cherry	+\$0
<b>HY</b>	walnut on cherry	+\$0
<b>LA</b>	light ash	+\$0
<b>LBA</b>	clear on ash	+\$0
<b>LBB</b>	oak on ash	+\$0
<b>LBC</b>	walnut on ash	+\$0
<b>LBD</b>	dark brown walnut	+\$0
<b>LBF</b>	neutral twill	+\$0
<b>LBG</b>	sarum twill	+\$0
<b>LBH</b>	earthen twill	+\$0
<b>LBJ</b>	graphite twill	+\$0
<b>LBK</b>	pewter mesh	+\$0
<b>LBL</b>	steel mesh	+\$0
<b>LBM</b>	crisp linen	+\$0
<b>LBN</b>	classic linen	+\$0
<b>LBP</b>	casual linen	+\$0
<b>LBQ</b>	white twill	+\$0
<b>LBR</b>	phantom ecru	+\$0
<b>LBS</b>	phantom cocoa	+\$0
<b>LBU</b>	medium matte walnut	+\$0
<b>LBV</b>	warm grey teak	+\$0
<b>LU</b>	soft white	+\$0
<b>WL</b>	sandstone	+\$0
<b>WN</b>	warm grey neutral	+\$0

## Step 7. Edge Finish

For laminate/thermoplastic edge (L)

<b>76</b>	light brown walnut	+\$0
<b>8Q</b>	folkstone grey	+\$0
<b>91</b>	white	+\$0
<b>98</b>	studio white	+\$0
<b>BU</b>	black umber	+\$0
<b>CL</b>	cool grey neutral	+\$0
<b>G2</b>	graphite satin	+\$0
<b>HF</b>	inner tone light	+\$0
<b>HM</b>	natural maple	+\$0
<b>HP</b>	light anigre	+\$0

## Laminate Screen, Chase Attached

*continued*

<b>HT</b>	inner tone	+\$0
<b>HX</b>	aged cherry	+\$0
<b>HY</b>	walnut on cherry	+\$0
<b>LA</b>	light ash	+\$0
<b>LBA</b>	clear on ash	+\$0
<b>LBB</b>	oak on ash	+\$0
<b>LBC</b>	walnut on ash	+\$0
<b>LBD</b>	dark brown walnut	+\$0
<b>LBF</b>	neutral twill	+\$0
<b>LBG</b>	sarum twill	+\$0
<b>LBH</b>	earthen twill	+\$0
<b>LBJ</b>	graphite twill	+\$0
<b>LBK</b>	pewter mesh	+\$0
<b>LBL</b>	steel mesh	+\$0
<b>LBM</b>	crisp linen	+\$0
<b>LBN</b>	classic linen	+\$0
<b>LBP</b>	casual linen	+\$0
<b>LBQ</b>	white twill	+\$0
<b>LBR</b>	phantom ecru	+\$0
<b>LBS</b>	phantom cocoa	+\$0
<b>LBU</b>	medium matte walnut	+\$0
<b>LBV</b>	warm grey teak	+\$0
<b>LU</b>	soft white	+\$0
<b>MT</b>	medium tone	+\$0
<b>WL</b>	sandstone	+\$0
<b>WN</b>	warm grey neutral	+\$0

---

*For laminate/universal edge (U)*

<b>PLY</b>	plywood edge	+\$50
------------	--------------	-------

# Marker Board Screen, Chase Attached

FG118.

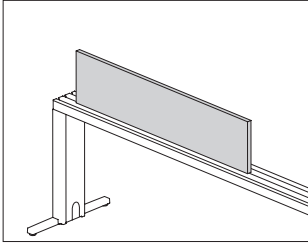

## Product Information

### Description

This marker board laminate screen attaches anywhere along the top of a Canvas Vista™ chase. It extends the overall height to provide boundary and layering with a white dry-erase marker board face. Marker board is nonmagnetic. Attachment hardware included.

### Notes

Screen width does not need to match chase width.

When using 84"-wide chase, specify 2 42"-wide screens to provide full screen coverage.

When using 96"-wide chase, specify 2 48"-wide screens to provide full screen coverage.

Marker board screen can be placed in any of the 3 tracks on top of chase.

Screens can mount over work surface tether brackets (FG290.) as long as screen bayonets do not collide with tether brackets.

Screen actual heights are 14.64" (15), 18.64" (19), and 25.64" (26).

For proper support information, see planning guide.

## Dimensions

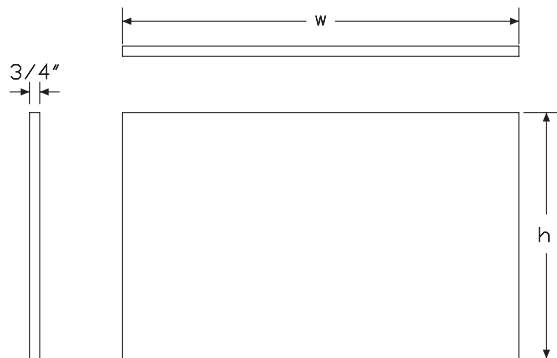

## Specification Information

### Step 1.

### FG118.

### Step 2. Height

<b>15</b>	15" high (to reach 42" datum)
<b>19</b>	19" high (to reach 46" datum)
<b>26</b>	26" high (to reach 53" datum)

### Step 3. Width

<b>24</b>	24" wide
<b>30</b>	30" wide
<b>36</b>	36" wide
<b>42</b>	42" wide
<b>48</b>	48" wide
<b>60</b>	60" wide
<b>66</b>	66" wide
<b>72</b>	72" wide

### Prices for Steps 1-3.

		<b>24</b>	<b>30</b>	<b>36</b>	<b>42</b>	<b>48</b>	<b>60</b>	
<b>FG118. 15</b>		\$557	615	673	731	787	903	
	<b>19</b>	\$659	712	765	819	873	979	
	<b>26</b>	\$760	831	902	973	1044	1186	
							<b>66</b>	<b>72</b>
<b>FG118. 15</b>						\$949	994	
	<b>19</b>					\$1025	1070	
	<b>26</b>					\$1272	1358	

# Single Sided Boundary Screen FG303.

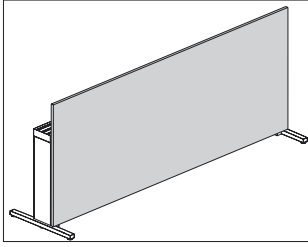

### Product Information

#### Description

This laminate or veneer screen provides privacy and modesty above and below 1 side of a Canvas Vista™ chase for single-sided chase applications. It attaches to the underside of the chase. Mounting bracket finish is black.

#### Notes

It is best to specify boundary screen width to match chase width.  
 To provide full screen coverage when using an 84"-wide chase, specify 2 42"-wide boundary screens.  
 To provide full screen coverage when using a 96"-wide chase, specify 2 48"-wide boundary screens.  
 Boundary screen can be used with both a T-leg (FG119.) and a post leg (FG117.). When using a T-leg, specify T-leg (1) application to ensure the screen can sit above the T-leg foot. When using a post leg, specify post leg (2) application to allow the screen to extend to the bottom of the post leg foot.

#### Dimensions

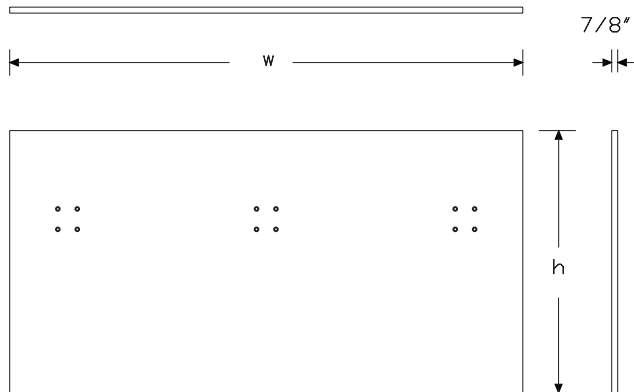

### Specification Information

#### Step 1.

**FG303.**

#### Step 2. Height

- 36** 36" high
- 42** 42" high
- 46** 46" high

#### Step 3. Width

- 42** 42" wide
- 48** 48" wide
- 60** 60" wide
- 66** 66" wide
- 72** 72" wide

#### Step 4. Application

- 1** for use with t-leg (screen sits above the t-leg foot)
- 2** for use with post leg (screen goes to the bottom of the foot)

#### Step 5. Surface Material

- L** laminate/thermoplastic edge
- U** laminate/universal edge
- W** veneer/veneer edge A

#### Prices for Steps 1-5.

		<b>1L</b>	<b>1U</b>	<b>1W</b>	<b>2L</b>	<b>2U</b>	<b>2W</b>
<b>FG303. 36</b>	<b>42</b>	\$649	649	1414	681	681	1556
	<b>48</b>	\$708	708	1525	744	744	1678
	<b>60</b>	\$768	768	1637	807	807	1801
	<b>66</b>	\$828	828	1748	869	869	1923
	<b>72</b>	\$887	887	1860	931	931	2046
<b>42</b>	<b>42</b>	\$664	664	1490	697	697	1639
	<b>48</b>	\$726	726	1601	762	762	1761
	<b>60</b>	\$787	787	1713	827	827	1884
	<b>66</b>	\$849	849	1824	892	892	2007
	<b>72</b>	\$912	912	1936	958	958	2129
<b>46</b>	<b>42</b>	\$679	679	1561	713	713	1717
	<b>48</b>	\$744	744	1672	781	781	1839
	<b>60</b>	\$809	809	1784	849	849	1962
	<b>66</b>	\$874	874	1895	917	917	2085
	<b>72</b>	\$937	937	2007	984	984	2207

#### Step 6. Grain Direction

- HRG** horizontal grain + \$0
- VTG** vertical grain + \$0

# Single Sided Boundary Screen

continued

Canvas Vista™ Screens - Chase Attach

For 66" wide (66) or 72" wide (72) with laminate/thermoplastic edge (L), or laminate/universal edge (U)

**HRG** horizontal grain +\$0

Step 7. Mounting Bracket Finish

**BK** black +\$0

Step 8. Surface Finish

For laminate/thermoplastic edge (L) or laminate/universal edge (U)

<b>76</b>	light brown walnut	+\$0
<b>8Q</b>	folkstone grey	+\$0
<b>91</b>	white	+\$0
<b>98</b>	studio white	+\$0
<b>CL</b>	cool grey neutral	+\$0
<b>G1</b>	graphite	+\$0
<b>HM</b>	natural maple	+\$0
<b>HP</b>	light anigre	+\$0
<b>HX</b>	aged cherry	+\$0
<b>HY</b>	walnut on cherry	+\$0
<b>LA</b>	light ash	+\$0
<b>LBA</b>	clear on ash	+\$0
<b>LBB</b>	oak on ash	+\$0
<b>LBC</b>	walnut on ash	+\$0
<b>LBD</b>	dark brown walnut	+\$0
<b>LBF</b>	neutral twill	+\$0
<b>LBG</b>	sarum twill	+\$0
<b>LBH</b>	earthen twill	+\$0
<b>LBJ</b>	graphite twill	+\$0
<b>LBK</b>	pewter mesh	+\$0
<b>LBL</b>	steel mesh	+\$0
<b>LBM</b>	crisp linen	+\$0
<b>LBN</b>	classic linen	+\$0
<b>LBP</b>	casual linen	+\$0
<b>LBQ</b>	white twill	+\$0
<b>LBR</b>	phantom ecru	+\$0
<b>LBS</b>	phantom cocoa	+\$0
<b>LBU</b>	medium matte walnut	+\$0
<b>LBV</b>	warm grey teak	+\$0
<b>LU</b>	soft white	+\$0
<b>WL</b>	sandstone	+\$0
<b>WN</b>	warm grey neutral	+\$0

For veneer/veneer edge (W)

<b>2U</b>	light brown walnut	+\$0
<b>40</b>	dark brown walnut	+\$0
<b>ED</b>	aged cherry	+\$0
<b>EK</b>	medium red walnut	+\$0
<b>ET</b>	clear on ash	+\$0
<b>EU</b>	oak on ash	+\$0
<b>EV</b>	walnut on ash	+\$0
<b>EW</b>	medium matte walnut	+\$0
<b>UL</b>	natural maple	+\$0
<b>UX</b>	walnut on cherry	+\$0

Step 9. Edge Finish

For laminate/thermoplastic edge (L)

<b>76</b>	light brown walnut	+\$0
<b>8Q</b>	folkstone grey	+\$0
<b>91</b>	white	+\$0
<b>98</b>	studio white	+\$0
<b>BU</b>	black umber	+\$0
<b>CL</b>	cool grey neutral	+\$0
<b>G2</b>	graphite satin	+\$0
<b>HF</b>	inner tone light	+\$0
<b>HM</b>	natural maple	+\$0
<b>HP</b>	light anigre	+\$0
<b>HT</b>	inner tone	+\$0
<b>HX</b>	aged cherry	+\$0
<b>HY</b>	walnut on cherry	+\$0
<b>LA</b>	light ash	+\$0
<b>LBA</b>	clear on ash	+\$0
<b>LBB</b>	oak on ash	+\$0
<b>LBC</b>	walnut on ash	+\$0
<b>LBD</b>	dark brown walnut	+\$0
<b>LBF</b>	neutral twill	+\$0
<b>LBG</b>	sarum twill	+\$0
<b>LBH</b>	earthen twill	+\$0
<b>LBJ</b>	graphite twill	+\$0
<b>LBK</b>	pewter mesh	+\$0
<b>LBL</b>	steel mesh	+\$0
<b>LBM</b>	crisp linen	+\$0
<b>LBN</b>	classic linen	+\$0
<b>LBP</b>	casual linen	+\$0
<b>LBQ</b>	white twill	+\$0
<b>LBR</b>	phantom ecru	+\$0
<b>LBS</b>	phantom cocoa	+\$0
<b>LBU</b>	medium matte walnut	+\$0
<b>LBV</b>	warm grey teak	+\$0

# Single Sided Boundary Screen

*continued*

<b>LU</b>	soft white	+\$0
<b>MT</b>	medium tone	+\$0
<b>WL</b>	sandstone	+\$0
<b>WN</b>	warm grey neutral	+\$0

---

*For laminate/universal edge (U)*

<b>PLY</b>	plywood edge	+\$50
------------	--------------	-------

# Open Frame Screen, Surface Attached

FG345.

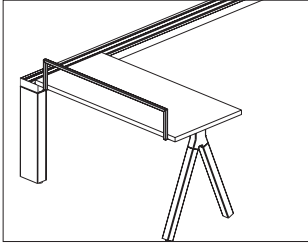

### Product Information

#### Description

This steel tube screen attaches to a Canvas Vista™ work surface to create a sense of boundary without an enclosed barrier. Attachment hardware included.

#### Notes

Screen is flush with back edge of surface.

Screen is 8" high to reach the 36" datum or 14" high to reach the 42" datum.

Actual screen height is 8.06" (36) or 13.63" (42) from bottom of work surface to top of screen; actual width is 42".

A movable insert (FG430.) can snap onto the 42"-high open frame screen and is user movable. Order separately.

There is enough clearance for a Vista modesty screen (FG346., FG348.) below the work surface.

Steel frame provides magnetic ability.

#### Dimensions

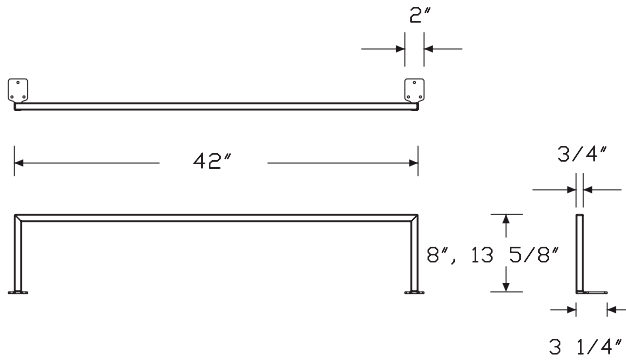

### Specification Information

#### Step 1.

#### FG345.

#### Step 2. Height

**36** 36" high

**42** 42" high

#### Step 3. Width

**42** 42" wide

#### Prices for Steps 1-3.

	<b>42</b>
<b>FG345. 36</b>	\$360
<b>42</b>	\$385

#### Step 4. Screen Finish

#### Smooth Paint

<b>91</b>	white	+\$0
<b>98</b>	studio white	+\$0
<b>SNA</b>	satin aluminum	+\$0
<b>SNC</b>	satin carbon	+\$0

#### Metallic Paint

<b>CN</b>	metallic champagne	+\$0
<b>MS</b>	metallic silver	+\$0

#### Sand Texture Paint

<b>BK</b>	black	+\$0
<b>G1</b>	graphite	+\$0

Vista Modesty Screen-Handed, FG346.  
Surface Attached

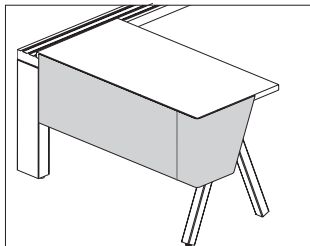

**Product Information**

**Description**

This sheet metal modesty screen attaches to a Canvas Vista™ work surface that is tethered to the chase. The screen wraps around 1 end of the work surface. Attachment hardware included.

**Notes**

Bottom edge of screen is 15" below top of work surface.  
 For surfaces 1 1/8" thick, the modesty is flush with top of surface. For surfaces 1 1/4" thick, surface will be 1/8" proud of screen top edge.  
 Recommended mounting creates a 1" gap between back edge of surface and the screen to accommodate cable routing and the attachment or clamp-mounting of other hardware to the surface.  
 There is enough clearance for an open frame screen (FG345.) to be mounted above the work surface. Order separately.  
 For work surface that overlaps the chase, specify screen width 6" shorter than work surface width.  
 When seated at the work surface, left hand return (L) is on the left and right hand return (R) is on the right.

**Dimensions**

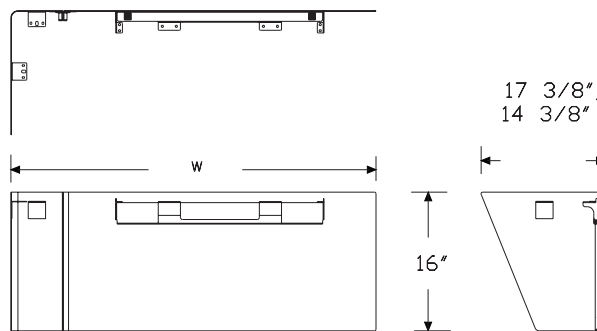

(L) Left hand return

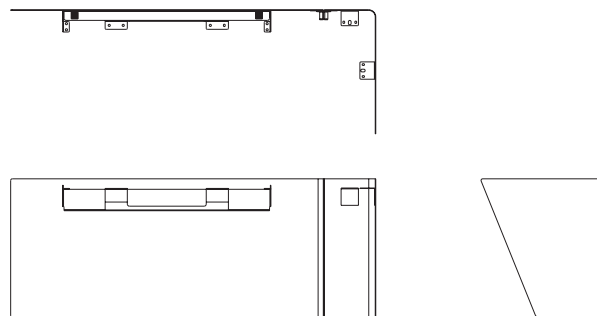

(R) Right hand return

Canvas Vista™ Screens - Surface Attach

Vista Modesty Screen-Handed,  
Surface Attached *continued*

**Specification Information**

Step 1.

**FG346.**

Step 2. Depth

**24** 24" deep

**30** 30" deep

Step 3. Width

**42** 42" wide

**48** 48" wide

**54** 54" wide

**60** 60" wide

**66** 66" wide

**72** 72" wide

Step 4. Type

**L** left hand return

**R** right hand return

Prices for Steps 1-4.

		L	R
<b>FG346.</b>	<b>24 42</b>	\$745	745
	<b>48</b>	\$775	775
	<b>54</b>	\$809	809
	<b>60</b>	\$841	841
	<b>66</b>	\$900	900
	<b>72</b>	\$958	958
	<b>30 42</b>	\$765	765
	<b>48</b>	\$796	796
	<b>54</b>	\$829	829
	<b>60</b>	\$861	861
	<b>66</b>	\$920	920
	<b>72</b>	\$978	978

Step 5. Screen Finish

Smooth Paint

**8Q** folkstone grey +\$0

**91** white +\$0

**98** studio white +\$0

**CL** cool grey neutral +\$0

**WL** sandstone +\$0

**WN** warm grey neutral +\$0

Metallic Paint

**CN** metallic champagne +\$0

**EH** metallic bronze +\$0

**MS** metallic silver +\$0

Sand Texture Paint

**BK** black +\$0

**G1** graphite +\$0

Vista Privacy + Modesty Screen - FG347.  
 Handed, Surface Attached

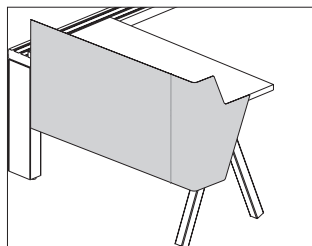

**Product Information**

**Description**

This sheet metal privacy + modesty screen attaches to a Canvas Vista™ work surface that is tethered to the chase. The screen wraps around 1 end of the work surface. Attachment hardware included.

**Notes**

The privacy top edge is 7" above top of work surface at a 36" datum height. Bottom edge of screen is 15" below top of work surface.  
 Recommended mounting creates a 1" gap between back edge of surface and the screen to accommodate cable routing and the attachment or clamp-mounting of other hardware to the surface.  
 There is not enough clearance for an open frame screen (FG345.) to be mounted above the work surface.  
 For work surface that overlaps the chase, specify screen width 6" shorter than work surface width.  
 When seated at the work surface, left hand return (L) is on the left and right hand return (R) is on the right.

**Dimensions**

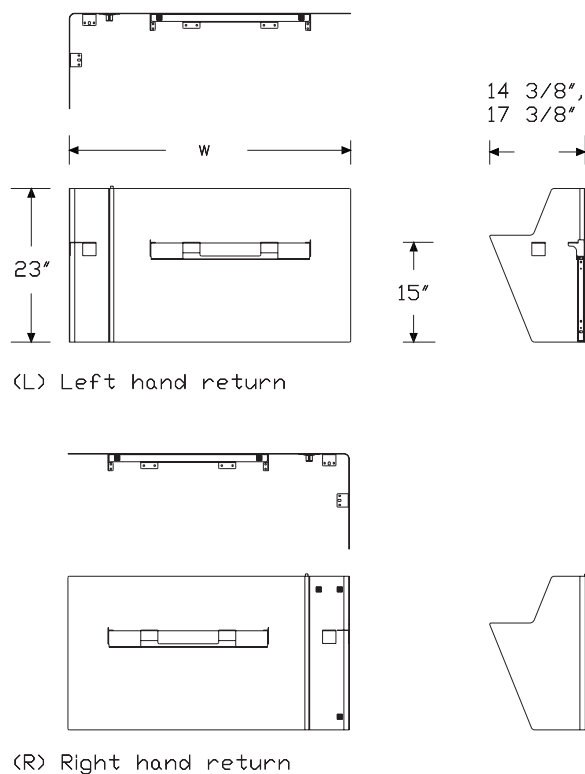

Canvas Vista™ Screens - Surface Attach

Vista Privacy + Modesty Screen -  
 Handed, Surface Attached *continued*

Canvas Vista™ Screens - Surface Attach

**Specification Information**

Step 1.  
**FG347.**

Step 2. Height  
**A36** 36" high/15" below work surface

Step 3. Depth  
**24** 24" deep  
**30** 30" deep

Step 4. Width  
**42** 42" wide  
**48** 48" wide  
**54** 54" wide  
**60** 60" wide  
**66** 66" wide  
**72** 72" wide

Step 5. Type  
**L** left hand return  
**R** right hand return

Prices for Steps 1-5.

	42L	42R	48L	48R	54L	54R
<b>FG347. A36 24</b>	\$958	958	996	996	1035	1035
<b>30</b>	\$983	983	1022	1022	1060	1060
	60L	60R	66L	66R	72L	72R
<b>FG347. A36 24</b>	\$1074	1074	1158	1158	1241	1241
<b>30</b>	\$1100	1100	1184	1184	1267	1267

Step 6. Screen Finish

Smooth Paint

<b>8Q</b>	folkstone grey	+\$0
<b>91</b>	white	+\$0
<b>98</b>	studio white	+\$0
<b>CL</b>	cool grey neutral	+\$0
<b>WL</b>	sandstone	+\$0
<b>WN</b>	warm grey neutral	+\$0

Metallic Paint

<b>CN</b>	metallic champagne	+\$0
<b>EH</b>	metallic bronze	+\$0
<b>MS</b>	metallic silver	+\$0

Sand Texture Paint

<b>BK</b>	black	+\$0
<b>G1</b>	graphite	+\$0

# Vista Modesty Screen-Double Sided, Surface Attached

FG348.

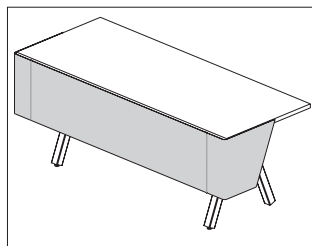

## Product Information

### Description

This sheet metal modesty screen attaches to a Canvas Vista™ freestanding fixed-height work surface. The screen wraps around both ends of the work surface. Attachment hardware included.

### Notes

Bottom edge of screen is 15" below top of work surface.

For surfaces 1 1/8" thick, the modesty is flush with top of surface. For surfaces 1 1/4" thick, surface will be 1/8" proud of screen top edge.

Recommended mounting creates a 1" gap between back edge of surface and the screen to accommodate cable routing and the attachment or clamp-mounting of other hardware to the surface.

There is enough clearance for an open frame screen (FG345.) to be mounted above the work surface. Order separately.

### Dimensions

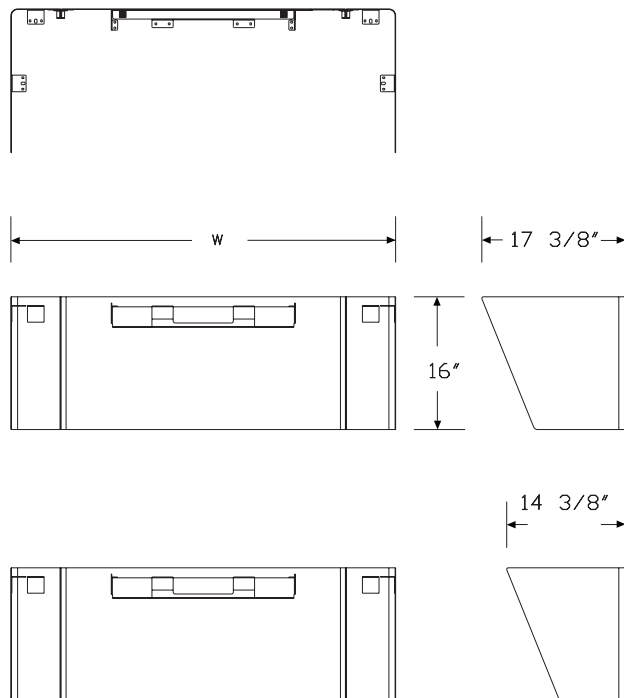

## Specification Information

### Step 1.

**FG348.**

### Step 2. Depth

**24** 24" deep

**30** 30" deep

### Step 3. Width

**48** 48" wide

**54** 54" wide

**60** 60" wide

**66** 66" wide

**72** 72" wide

### Prices for Steps 1-3.

	<b>48</b>	<b>54</b>	<b>60</b>	<b>66</b>	<b>72</b>
<b>FG348. 24</b>	\$895	915	935	1020	1105
<b>30</b>	\$925	946	966	1051	1135

### Step 4. Screen Finish

#### Smooth Paint

<b>8Q</b>	folkstone grey	+\$0
<b>91</b>	white	+\$0
<b>98</b>	studio white	+\$0
<b>CL</b>	cool grey neutral	+\$0
<b>WL</b>	sandstone	+\$0
<b>WN</b>	warm grey neutral	+\$0

#### Metallic Paint

<b>CN</b>	metallic champagne	+\$0
<b>EH</b>	metallic bronze	+\$0
<b>MS</b>	metallic silver	+\$0

#### Sand Texture Paint

<b>BK</b>	black	+\$0
<b>G1</b>	graphite	+\$0

Vista Privacy + Modesty Screen - FG349.  
Double Sided, Surface Attached

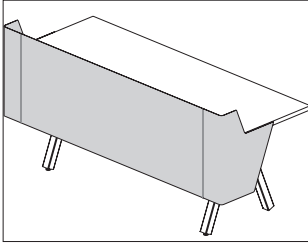

**Product Information**

**Description**

This sheet metal privacy + modesty screen attaches to a Canvas Vista™ freestanding fixed-height work surface. The screen wraps around both ends of the work surface. Attachment hardware included.

**Notes**

The privacy top edge is 7" above top of work surface at a 36" datum height. Bottom edge of screen is 15" below top of work surface.  
Recommended mounting creates a 1" gap between back edge of surface and the screen to accommodate cable routing and the attachment or clamp-mounting of other hardware to the surface.  
There is not enough clearance for an open frame screen (FG345.) to be mounted above the work surface.

**Dimensions**

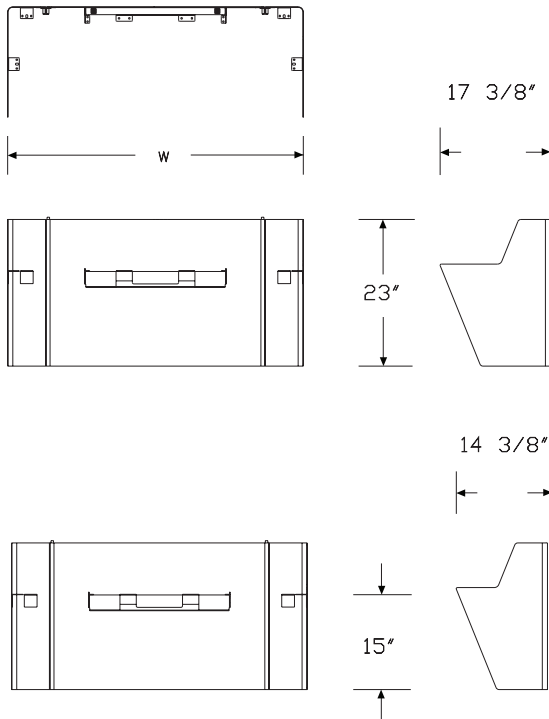

**Specification Information**

**Step 1.**

**FG349.**

**Step 2. Height**

**A36** 36" high/15" below work surface

**Step 3. Depth**

**24** 24" deep

**30** 30" deep

**Step 4. Width**

**48** 48" wide

**54** 54" wide

**60** 60" wide

**66** 66" wide

**72** 72" wide

**Prices for Steps 1-4.**

	48	54	60	66	72
<b>FG349. A36 24</b>	\$1100	1145	1191	1246	1317
<b>30</b>	\$1150	1196	1241	1305	1368

**Step 5. Screen Finish**

**Smooth Paint**

<b>8Q</b>	folkstone grey	+\$0
<b>91</b>	white	+\$0
<b>98</b>	studio white	+\$0
<b>CL</b>	cool grey neutral	+\$0
<b>WL</b>	sandstone	+\$0
<b>WN</b>	warm grey neutral	+\$0

**Metallic Paint**

<b>CN</b>	metallic champagne	+\$0
<b>EH</b>	metallic bronze	+\$0
<b>MS</b>	metallic silver	+\$0

**Sand Texture Paint**

<b>BK</b>	black	+\$0
<b>G1</b>	graphite	+\$0

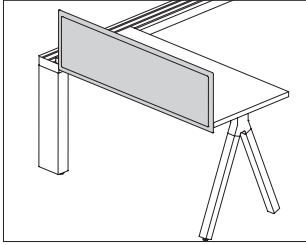

**Product Information**

**Description**

This tackable fabric screen attaches to a Canvas Vista™ work surface to provide boundary with a tackable surface. Attachment hardware included.

**Notes**

Screen widths are actual dimensions and extend to the end of Canvas Vista work surfaces.

Screen extends 4" below surface to hide attachment hardware.

Screen can be flush with back edge of surface, or provide a 1" gap.

Screens 48" wide and wider include an additional 1"-wide center mounting bracket.

For planning information, see planning guide.

**Dimensions**

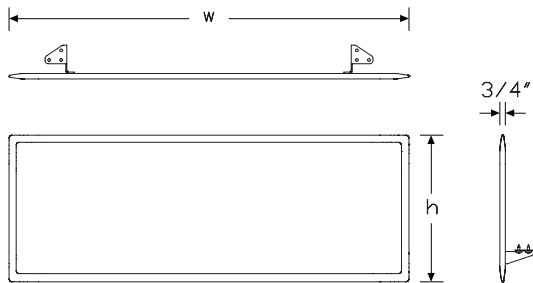

**Specification Information**

**Step 1.**

**FG351.**

**Step 2. Attachment**

**G** Vista surface attached

**Step 3. Height**

**42** 42" high

**46** 46" high

**53** 53" high

**Step 4. Width**

**42** 42" wide

**48** 48" wide

**54** 54" wide

**60** 60" wide

**66** 66" wide

**72** 72" wide

**Step 5. Surface Material**

*For 42" wide (42) or 48" wide (48)*

**R** tackable fabric, horizontal

**T** tackable fabric

*For 54" wide (54), 60" wide (60), 66" wide (66), or 72" wide (72)*

**R** tackable fabric, horizontal

**Prices for Steps 1-5.**

		<b>42R</b>	<b>42T</b>	<b>48R</b>	<b>48T</b>	<b>54R</b>	<b>60R</b>		
<b>FG351. G</b>	<b>42</b>	\$815	815	840	840	929	993		
	<b>46</b>	\$883	883	973	973	1066	1143		
	<b>53</b>	\$1112	1112	1173	1173	1241	1262		
								<b>66R</b>	<b>72R</b>
<b>FG351. G</b>	<b>42</b>					\$1066	1122		
	<b>46</b>					\$1204	1251		
	<b>53</b>					\$1297	1322		

**Step 6. Bracket Finish**

**G2** graphite satin +\$0

# Pari Screen, Surface Attached

continued

---

## Step 7. Fabric

---

### *For 42" wide (42) or 48" wide (48)*

---

Price Category C	+\$139
Price Category 1	+\$0
Price Category 2	+\$23
Price Category 3	+\$54
Price Category 4	+\$94
Price Category E	+\$234

---

### *For 54" wide (54) or 60" wide (60)*

---

Price Category 1	+\$0
Price Category 2	+\$27
Price Category 3	+\$65
Price Category 4	+\$113
Price Category E	+\$234
Price Category C	+\$163

---

### *For 66" wide (66) or 72" wide (72)*

---

Price Category 1	+\$0
Price Category 2	+\$33
Price Category 3	+\$78
Price Category 4	+\$135
Price Category E	+\$234
Price Category C	+\$195

---

# Pari Screen, Surface Attached with Modesty

FG353.

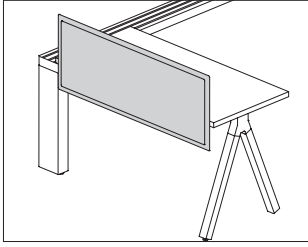

### Product Information

#### Description

This tackable fabric screen attaches to a Canvas Vista™ work surface to provide boundary and modesty with a tackable surface. An optional cable management trough is available. Trough finish is graphite. Attachment hardware included.

#### Notes

Screen widths are actual dimensions and extend to the end of Canvas Vista work surfaces.

Screen extends 9" below surface for modesty.

Screen can be flush with back edge of surface, or provide a 1" gap.

Screens 48" wide and wider include an additional 1"-wide center mounting bracket.

For planning information, see planning guide.

#### Dimensions

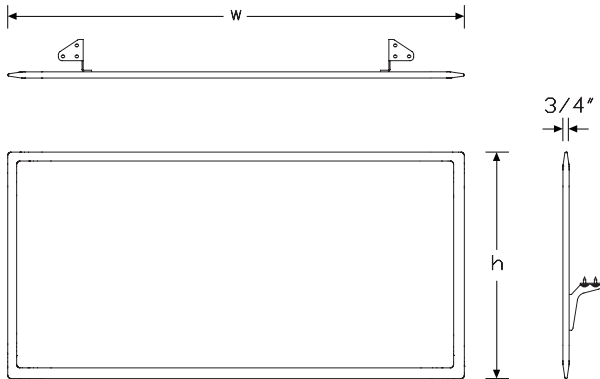

### Specification Information

#### Step 1.

**FG353.**

#### Step 2. Attachment

**G** Vista surface attached

#### Step 3. Height

**A42** 42" high/9" below surface

**A46** 46" high/9" below surface

**A53** 53" high/9" below surface

#### Step 4. Width

**42** 42" wide

**48** 48" wide

**54** 54" wide

**60** 60" wide

**66** 66" wide

**72** 72" wide

#### Step 5. Surface Material

*For 42" wide (42) or 48" wide (48)*

**R** tackable fabric, horizontal

**T** tackable fabric

*For 54" wide (54), 60" wide (60), 66" wide (66), or 72" wide (72)*

**R** tackable fabric, horizontal

#### Prices for Steps 1-5.

		<b>42R</b>	<b>42T</b>	<b>48R</b>	<b>48T</b>	<b>54R</b>	<b>60R</b>		
<b>FG353. G</b>	<b>A42</b>	\$926	926	1030	1030	1158	1184		
	<b>A46</b>	\$1087	1087	1168	1168	1225	1297		
	<b>A53</b>	\$1204	1204	1297	1297	1344	1389		
								<b>66R</b>	<b>72R</b>
<b>FG353. G</b>	<b>A42</b>					\$1277	1312		
	<b>A46</b>					\$1364	1396		
	<b>A53</b>					\$1507	1535		

#### Step 6. Cable Trough

**NC** no cable way +\$0

**CW** cable way +\$25

#### Step 7. Cable Trough Finish

**G2** graphite satin +\$0

# Pari Screen, Surface Attached with Modesty *continued*

Step 8. Bracket Finish		
<b>G2</b>	graphite satin	+\$0

Step 9. Fabric		
----------------	--	--

<i>For 42" wide (42) or 48" wide (48)</i>		
	Price Category C	+\$279
	Price Category 1	+\$0
	Price Category 2	+\$48
	Price Category 3	+\$110
	Price Category 4	+\$188
	Price Category E	+\$425

<i>For 54" wide (54) or 60" wide (60)</i>		
	Price Category 1	+\$0
	Price Category 2	+\$58
	Price Category 3	+\$132
	Price Category 4	+\$227
	Price Category E	+\$513
	Price Category C	+\$335

<i>For 66" wide (66) or 72" wide (72)</i>		
	Price Category 1	+\$0
	Price Category 2	+\$73
	Price Category 3	+\$165
	Price Category 4	+\$283
	Price Category E	+\$641
	Price Category C	+\$418

Canvas Vista™ Screens - Surface Attach

# Flat Edge Screen, Surface Attached

FG356.

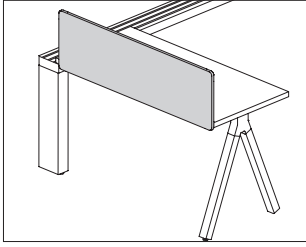

## Product Information

### Description

This tackable fabric screen attaches to a Canvas Vista™ work surface to provide boundary with a tackable surface. Attachment hardware included.

### Notes

Screen widths are actual dimensions and extend to the end of Canvas work surfaces.

Screen extends 4" below surface to hide attachment hardware.

Screen can be flush with back edge of surface, or provide a 1" gap.

Screens 48" wide and wider include an additional 1"-wide center mounting bracket.

For planning information, see planning guide.

## Dimensions

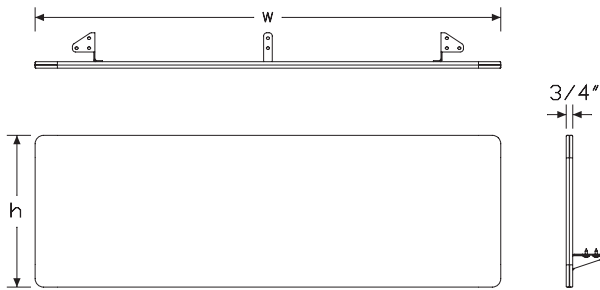

## Specification Information

### Step 1.

**FG356.**

### Step 2. Attachment

**G** Vista surface attached

### Step 3. Height

**42** 42" high

**46** 46" high

**53** 53" high

### Step 4. Width

**42** 42" wide

**48** 48" wide

**54** 54" wide

**60** 60" wide

**66** 66" wide

**72** 72" wide

### Step 5. Surface Material

*For 42" wide (42) or 48" wide (48)*

**R** tackable fabric, horizontal

**T** tackable fabric

*For 54" wide (54), 60" wide (60), 66" wide (66), or 72" wide (72)*

**R** tackable fabric, horizontal

### Prices for Steps 1-5.

		<b>42R</b>	<b>42T</b>	<b>48R</b>	<b>48T</b>	<b>54R</b>	<b>60R</b>		
<b>FG356. G</b>	<b>42</b>	\$624	624	667	667	709	767		
	<b>46</b>	\$690	690	761	761	833	901		
	<b>53</b>	\$937	937	965	965	992	1019		
								<b>66R</b>	<b>72R</b>
<b>FG356. G</b>	<b>42</b>					\$803	855		
	<b>46</b>					\$942	983		
	<b>53</b>					\$1024	1030		

### Step 6. Bracket Finish

**G2** graphite satin +\$0

# Flat Edge Screen, Surface Attached *continued*

---

## Step 7. Fabric

---

### *For 42" wide (42) or 48" wide (48)*

Price Category C	+\$139
Price Category 1	+\$0
Price Category 2	+\$24
Price Category 3	+\$54
Price Category 4	+\$92
Price Category E	+\$209

---

### *For 54" wide (54), 60" wide (60), 66" wide (66), or 72" wide (72)*

Price Category 1	+\$0
Price Category 2	+\$31
Price Category 3	+\$70
Price Category 4	+\$119
Price Category E	+\$270
Price Category C	+\$177

# Flat Edge Screen, Surface Attached with Modesty

FG357.

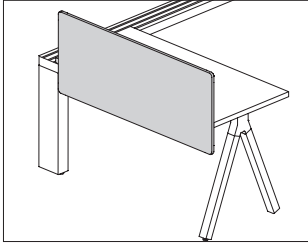

### Product Information

#### Description

This tackable fabric screen attaches to a Canvas Vista™ work surface to provide boundary and modesty with a tackable surface. An optional cable management trough is available. Trough finish is graphite. Attachment hardware included.

#### Notes

Screen widths are actual dimensions and extend to the end of Canvas Vista work surfaces.

Screen extends 9" below surface for modesty.

Screen can be flush with back edge of surface, or provide a 1" gap.

Screens 48" wide and wider include an additional 1"-wide center mounting bracket.

For planning information, see planning guide.

#### Dimensions

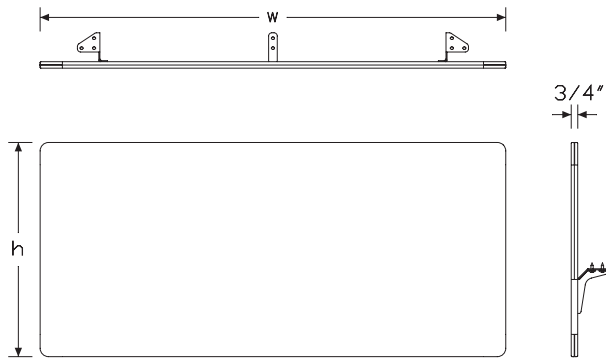

### Specification Information

#### Step 1.

**FG357.**

#### Step 2. Attachment

**G** Vista surface attached

#### Step 3. Height

**A42** 42" high/9" below surface

**A46** 46" high/9" below surface

**A53** 53" high/9" below surface

#### Step 4. Width

**42** 42" wide

**48** 48" wide

**54** 54" wide

**60** 60" wide

**66** 66" wide

**72** 72" wide

#### Step 5. Surface Material

*For 42" wide (42) or 48" wide (48)*

**R** tackable fabric, horizontal

**T** tackable fabric

*For 54" wide (54), 60" wide (60), 66" wide (66), or 72" wide (72)*

**R** tackable fabric, horizontal

#### Prices for Steps 1-5.

		<b>42R</b>	<b>42T</b>	<b>48R</b>	<b>48T</b>	<b>54R</b>	<b>60R</b>		
<b>FG357. G</b>	<b>A42</b>	\$690	690	729	729	766	843		
	<b>A46</b>	\$846	846	858	858	931	943		
	<b>A53</b>	\$968	968	981	981	994	1009		
						<b>66R</b>	<b>72R</b>		
<b>FG357. G</b>	<b>A42</b>					\$865	983		
	<b>A46</b>					\$970	1002		
	<b>A53</b>					\$1095	1130		

#### Step 6. Cable Trough

**NC** no cable way +\$0

**CW** cable way +\$25

#### Step 7. Cable Trough Finish

**G2** graphite satin +\$0

# Flat Edge Screen, Surface Attached with Modesty *continued*

Step 8. Bracket Finish		
<b>G2</b>	graphite satin	+\$0

Step 9. Fabric		
----------------	--	--

<i>For 42" wide (42) or 48" wide (48)</i>		
	Price Category C	+\$279
	Price Category 1	+\$0
	Price Category 2	+\$48
	Price Category 3	+\$110
	Price Category 4	+\$188
	Price Category E	+\$425

<i>For 54" wide (54), 60" wide (60), 66" wide (66), or 72" wide (72)</i>		
	Price Category 1	+\$0
	Price Category 2	+\$63
	Price Category 3	+\$144
	Price Category 4	+\$247
	Price Category E	+\$560
	Price Category C	+\$363

Canvas Vista™ Screens - Surface Attach

# Laminate Screen, Surface Attached

FG360.

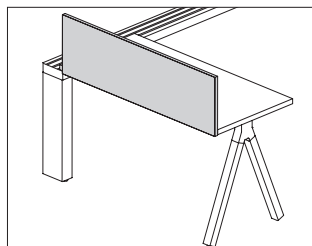

### Product Information

#### Description

This laminate screen attaches to a Canvas Vista™ work surface to provide boundary. Attachment hardware included.

#### Notes

Screen widths are actual dimensions and extend to the end of Canvas Vista work surfaces.

Screen extends 4" below surface to hide attachment hardware.

Screen can be flush with back edge of surface, or provide a 1" gap.

Screens 48" wide and wider include an additional 1"-wide center mounting bracket.

For additional product options, see Vary Easy Program in appendices.

#### Dimensions

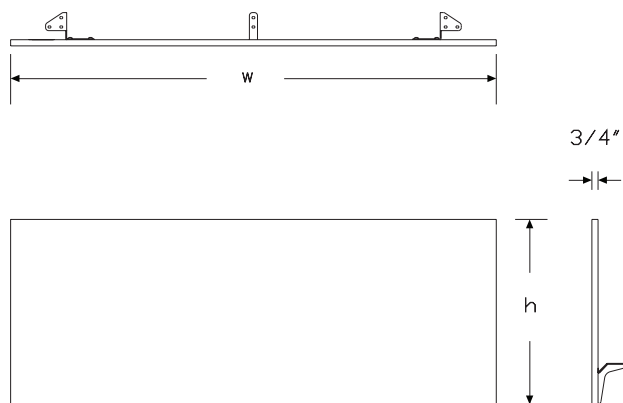

### Specification Information

#### Step 1.

**FG360.**

#### Step 2. Attachment

**G** Vista surface attached

#### Step 3. Height

**42** 42" high

**46** 46" high

#### Step 4. Width

**42** 42" wide

**48** 48" wide

**54** 54" wide

**60** 60" wide

**66** 66" wide

**72** 72" wide

#### Step 5. Surface Material

**L** laminate/thermoplastic edge

**U** laminate/universal edge

#### Prices for Steps 1-5.

		<b>42L</b>	<b>42U</b>	<b>48L</b>	<b>48U</b>	<b>54L</b>	<b>54U</b>
<b>FG360. G</b>	<b>42</b>	\$376	376	395	395	414	414
	<b>46</b>	\$463	463	482	482	501	501
		<b>60L</b>	<b>60U</b>	<b>66L</b>	<b>66U</b>	<b>72L</b>	<b>72U</b>
<b>FG360. G</b>	<b>42</b>	\$424	424	460	460	483	483
	<b>46</b>	\$510	510	549	549	572	572

#### Step 6. Grain Direction

For 42" wide (42), 48" wide (48), 54" wide (54), or 60" wide (60)

**HRG** horizontal grain +\$0

**VTG** vertical grain +\$0

For 66" wide (66) or 72" wide (72)

**HRG** horizontal grain +\$0

#### Step 7. Bracket Finish

**G2** graphite satin +\$0

# Laminate Screen, Surface Attached *continued*

Step 8. Surface Finish		
<b>76</b>	light brown walnut	+\$0
<b>8Q</b>	folkstone grey	+\$0
<b>91</b>	white	+\$0
<b>98</b>	studio white	+\$0
<b>CL</b>	cool grey neutral	+\$0
<b>G1</b>	graphite	+\$0
<b>HM</b>	natural maple	+\$0
<b>HP</b>	light anigre	+\$0
<b>HX</b>	aged cherry	+\$0
<b>HY</b>	walnut on cherry	+\$0
<b>LA</b>	light ash	+\$0
<b>LBA</b>	clear on ash	+\$0
<b>LBB</b>	oak on ash	+\$0
<b>LBC</b>	walnut on ash	+\$0
<b>LBD</b>	dark brown walnut	+\$0
<b>LBF</b>	neutral twill	+\$0
<b>LBG</b>	sarum twill	+\$0
<b>LBH</b>	earthen twill	+\$0
<b>LBJ</b>	graphite twill	+\$0
<b>LBK</b>	pewter mesh	+\$0
<b>LBL</b>	steel mesh	+\$0
<b>LBM</b>	crisp linen	+\$0
<b>LBN</b>	classic linen	+\$0
<b>LBP</b>	casual linen	+\$0
<b>LBQ</b>	white twill	+\$0
<b>LBR</b>	phantom ecru	+\$0
<b>LBS</b>	phantom cocoa	+\$0
<b>LBU</b>	medium matte walnut	+\$0
<b>LBV</b>	warm grey teak	+\$0
<b>LU</b>	soft white	+\$0
<b>WL</b>	sandstone	+\$0
<b>WN</b>	warm grey neutral	+\$0

<b>HT</b>	inner tone	+\$0
<b>HX</b>	aged cherry	+\$0
<b>HY</b>	walnut on cherry	+\$0
<b>LA</b>	light ash	+\$0
<b>LBA</b>	clear on ash	+\$0
<b>LBB</b>	oak on ash	+\$0
<b>LBC</b>	walnut on ash	+\$0
<b>LBD</b>	dark brown walnut	+\$0
<b>LBF</b>	neutral twill	+\$0
<b>LBG</b>	sarum twill	+\$0
<b>LBH</b>	earthen twill	+\$0
<b>LBJ</b>	graphite twill	+\$0
<b>LBK</b>	pewter mesh	+\$0
<b>LBL</b>	steel mesh	+\$0
<b>LBM</b>	crisp linen	+\$0
<b>LBN</b>	classic linen	+\$0
<b>LBP</b>	casual linen	+\$0
<b>LBQ</b>	white twill	+\$0
<b>LBR</b>	phantom ecru	+\$0
<b>LBS</b>	phantom cocoa	+\$0
<b>LBU</b>	medium matte walnut	+\$0
<b>LBV</b>	warm grey teak	+\$0
<b>LU</b>	soft white	+\$0
<b>MT</b>	medium tone	+\$0
<b>WL</b>	sandstone	+\$0
<b>WN</b>	warm grey neutral	+\$0

*For laminate/universal edge (U)*

<b>PLY</b>	plywood edge	+\$50
------------	--------------	-------

Step 9. Edge Finish

*For laminate/thermoplastic edge (L)*

<b>76</b>	light brown walnut	+\$0
<b>8Q</b>	folkstone grey	+\$0
<b>91</b>	white	+\$0
<b>98</b>	studio white	+\$0
<b>BU</b>	black umber	+\$0
<b>CL</b>	cool grey neutral	+\$0
<b>G2</b>	graphite satin	+\$0
<b>HF</b>	inner tone light	+\$0
<b>HM</b>	natural maple	+\$0
<b>HP</b>	light anigre	+\$0

# Laminate Screen, Surface Attached with Modesty

FG361.

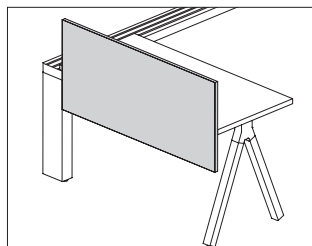

### Product Information

#### Description

This laminate screen attaches to a Canvas Vista™ work surface to provide boundary and modesty. An optional cable management trough is available. Trough finish is graphite. Attachment hardware included.

#### Notes

Screen widths are actual dimensions and extend to the end of Canvas Vista work surfaces.

Screen extends 9" below surface for modesty.

Screen can be flush with back edge of surface, or provide a 1" gap.

Screens 48" wide and wider include an additional 1"-wide center mounting bracket.

For additional product options, see Vary Easy Program in appendices.

#### Dimensions

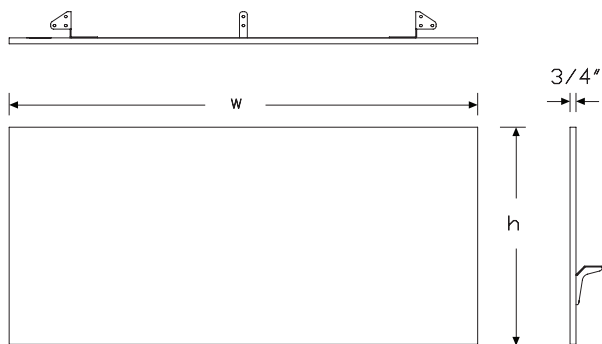

### Specification Information

#### Step 1.

**FG361.**

#### Step 2. Attachment

**G** Vista surface attached

#### Step 3. Height

**A42** 42" high/9" below surface

**A46** 46" high/9" below surface

#### Step 4. Width

**42** 42" wide

**48** 48" wide

**54** 54" wide

**60** 60" wide

**66** 66" wide

**72** 72" wide

#### Step 5. Surface Material

**L** laminate/thermoplastic edge

**U** laminate/universal edge

#### Prices for Steps 1-5.

		42L	42U	48L	48U	54L	54U
<b>FG361. G</b>	<b>A42</b>	\$414	414	435	435	455	455
	<b>A46</b>	\$510	510	531	531	551	551
		60L	60U	66L	66U	72L	72U
<b>FG361. G</b>	<b>A42</b>	\$466	466	500	500	523	523
	<b>A46</b>	\$561	561	600	600	621	621

#### Step 6. Grain Direction

For 42" wide (42), 48" wide (48), 54" wide (54), or 60" wide (60)

**HRG** horizontal grain +\$0

**VTG** vertical grain +\$0

For 66" wide (66) or 72" wide (72)

**HRG** horizontal grain +\$0

#### Step 7. Cable Way

**CW** cable way +\$25

**NC** no cable way +\$0

#### Step 8. Cable Way Finish

**G2** graphite satin +\$0

# Laminate Screen, Surface Attached with Modesty *continued*

Step 9. Bracket Finish		
<b>G2</b>	graphite satin	+\$0

Step 10. Surface Finish		
<b>76</b>	light brown walnut	+\$0
<b>8Q</b>	folkstone grey	+\$0
<b>91</b>	white	+\$0
<b>98</b>	studio white	+\$0
<b>CL</b>	cool grey neutral	+\$0
<b>G1</b>	graphite	+\$0
<b>HM</b>	natural maple	+\$0
<b>HP</b>	light anigre	+\$0
<b>HX</b>	aged cherry	+\$0
<b>HY</b>	walnut on cherry	+\$0
<b>LA</b>	light ash	+\$0
<b>LBA</b>	clear on ash	+\$0
<b>LBB</b>	oak on ash	+\$0
<b>LBC</b>	walnut on ash	+\$0
<b>LBD</b>	dark brown walnut	+\$0
<b>LBF</b>	neutral twill	+\$0
<b>LBG</b>	sarum twill	+\$0
<b>LBH</b>	earthen twill	+\$0
<b>LBJ</b>	graphite twill	+\$0
<b>LBK</b>	pewter mesh	+\$0
<b>LBL</b>	steel mesh	+\$0
<b>LBM</b>	crisp linen	+\$0
<b>LBN</b>	classic linen	+\$0
<b>LBP</b>	casual linen	+\$0
<b>LBQ</b>	white twill	+\$0
<b>LBR</b>	phantom ecru	+\$0
<b>LBS</b>	phantom cocoa	+\$0
<b>LBU</b>	medium matte walnut	+\$0
<b>LBV</b>	warm grey teak	+\$0
<b>LU</b>	soft white	+\$0
<b>WL</b>	sandstone	+\$0
<b>WN</b>	warm grey neutral	+\$0

<b>HF</b>	inner tone light	+\$0
<b>HM</b>	natural maple	+\$0
<b>HP</b>	light anigre	+\$0
<b>HT</b>	inner tone	+\$0
<b>HX</b>	aged cherry	+\$0
<b>HY</b>	walnut on cherry	+\$0
<b>LA</b>	light ash	+\$0
<b>LBA</b>	clear on ash	+\$0
<b>LBB</b>	oak on ash	+\$0
<b>LBC</b>	walnut on ash	+\$0
<b>LBD</b>	dark brown walnut	+\$0
<b>LBF</b>	neutral twill	+\$0
<b>LBG</b>	sarum twill	+\$0
<b>LBH</b>	earthen twill	+\$0
<b>LBJ</b>	graphite twill	+\$0
<b>LBK</b>	pewter mesh	+\$0
<b>LBL</b>	steel mesh	+\$0
<b>LBM</b>	crisp linen	+\$0
<b>LBN</b>	classic linen	+\$0
<b>LBP</b>	casual linen	+\$0
<b>LBQ</b>	white twill	+\$0
<b>LBR</b>	phantom ecru	+\$0
<b>LBS</b>	phantom cocoa	+\$0
<b>LBU</b>	medium matte walnut	+\$0
<b>LBV</b>	warm grey teak	+\$0
<b>LU</b>	soft white	+\$0
<b>MT</b>	medium tone	+\$0
<b>WL</b>	sandstone	+\$0
<b>WN</b>	warm grey neutral	+\$0

<i>For laminate/universal edge (U)</i>		
<b>PLY</b>	plywood edge	+\$50

Step 11. Edge Finish		
----------------------	--	--

<i>For laminate/thermoplastic edge (L)</i>		
<b>76</b>	light brown walnut	+\$0
<b>8Q</b>	folkstone grey	+\$0
<b>91</b>	white	+\$0
<b>98</b>	studio white	+\$0
<b>BU</b>	black umber	+\$0
<b>CL</b>	cool grey neutral	+\$0
<b>G2</b>	graphite satin	+\$0

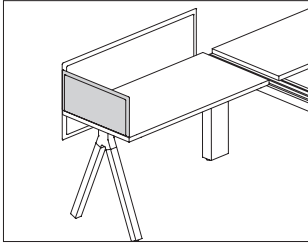

**Product Information**

**Description**

This tackable fabric screen attaches to a work surface either at the seam or at the right or left edge to provide division and boundary between workers. It attaches with no interference from supports below the work surface. Attachment hardware included.

**Notes**

Screen height is 13 1/2" or 17 1/2" above work surface.  
 Screen width matches work surface depths that have a 1" gap at the back edge.  
 2 attachment methods ship with the end-of-run right handed (GR) and end-of-run left handed (GL) screen. The screen can be installed using the bracket, or using threaded screws that drill bayonets directly into the surface. See planning guide for exact location of holes.  
 See planning guide for applications.

**Dimensions**

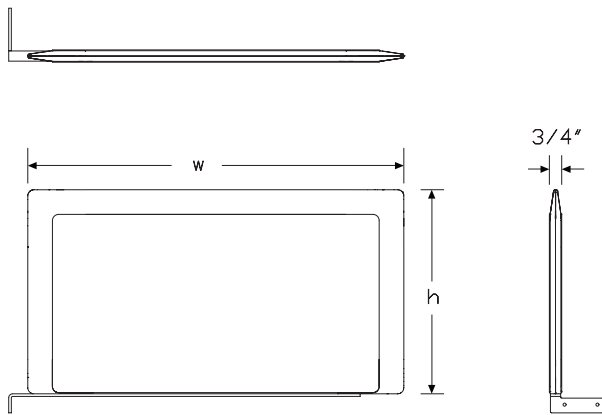

**Specification Information**

**Step 1.**

**FG354.**

**Step 2. Attachment**

- GL** Vista surface attached, end of run left handed
- GR** Vista surface attached, end of run right handed

**Step 3. Height**

- 42** 42" high
- 46** 46" high

**Step 4. Width**

- 24** 24" wide
- 30** 30" wide

**Step 5. Surface Material**

- R** tackable fabric, horizontal
- T** tackable fabric

**Prices for Steps 1-5.**

	<b>24R</b>	<b>24T</b>	<b>30R</b>	<b>30T</b>
<b>FG354. GL 42</b>	\$865	865	896	896
<b>46</b>	\$911	911	947	947
<b>GR 42</b>	\$865	865	896	896
<b>46</b>	\$911	911	947	947

**Step 6. Bracket Finish**

<b>8Q</b>	folkstone grey			+\$0
<b>91</b>	white			+\$0
<b>98</b>	studio white			+\$0
<b>BK</b>	black			+\$0
<b>G1</b>	graphite			+\$0
<b>WL</b>	sandstone			+\$0
<b>WN</b>	warm grey neutral			+\$0

**Step 7. Fabric**

Price Category C		+\$102
Price Category 1		+\$0
Price Category 2		+\$17
Price Category 3		+\$40
Price Category 4		+\$70
Price Category E		+\$169

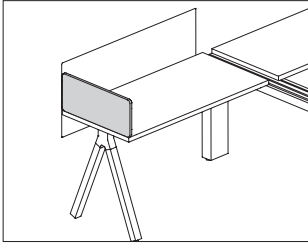

**Product Information**

**Description**

This tackable fabric screen attaches to a work surface either at the seam or at the right or left edge to provide division and boundary between workers. It attaches with no interference from supports below the work surface. Attachment hardware included.

**Notes**

Screen height is 13 1/2" or 17 1/2" above work surface.

Screen width matches work surface depths that have a 1" gap at the back edge.

2 attachment methods ship with the end-of-run right handed (GR) and end-of-run left handed (GL) screen. The screen can be installed using the bracket, or using threaded screws that drill bayonets directly into the surface. See planning guide for exact location of holes.

See planning guide for applications.

**Dimensions**

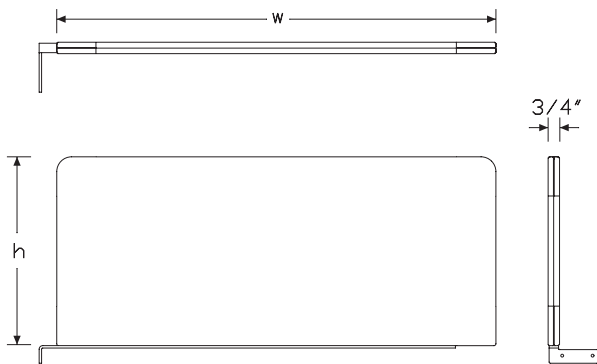

Canvas Vista™ Screens - Surface Attach

**Specification Information**

**Step 1.**

**FG358.**

**Step 2. Attachment**

**GL** Vista surface attached, end of run left handed

**GR** Vista surface attached, end of run right handed

**Step 3. Height**

**42** 42" high

**46** 46" high

**Step 4. Width**

**24** 24" wide

**30** 30" wide

**Step 5. Surface Material**

**R** tackable fabric, horizontal

**T** tackable fabric

**Prices for Steps 1-5.**

	24R	24T	30R	30T
<b>FG358. GL 42</b>	\$536	536	566	566
<b>46</b>	\$582	582	618	618
<b>GR 42</b>	\$536	536	566	566
<b>46</b>	\$582	582	618	618

**Step 6. Bracket Finish**

<b>8Q</b> folkstone grey	+\$0
<b>91</b> white	+\$0
<b>98</b> studio white	+\$0
<b>BK</b> black	+\$0
<b>G1</b> graphite	+\$0
<b>WL</b> sandstone	+\$0
<b>WN</b> warm grey neutral	+\$0

**Step 7. Fabric**

Price Category C	+\$102
Price Category 1	+\$0
Price Category 2	+\$17
Price Category 3	+\$40
Price Category 4	+\$70
Price Category E	+\$169

# T-Light

FG600.

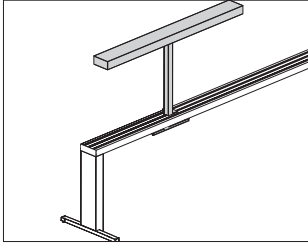

### Product Information

#### Description

This light mounts anywhere along the top of the chase in the center track. It turns on to full power by touching the stem. Touch once more to dim to 50%. Touch again to turn the lamp off. The energy-efficient light emitting diode (LED) has a 3000° Kelvin color temperature and CRI of 90+. Lamp is UL Listed.

#### Notes

Cord length from base of light to AC plug is approximately 10'.

Plastic cord cover included. Predetermined finish is black texture or folkstone grey.

For management of light cords, order cable manager, under chase (FG199.) separately. Cable manager attaches to underside of chase to hold and conceal cord and power block from T-light.

For proper support information and applications, see planning guide.

#### Dimensions

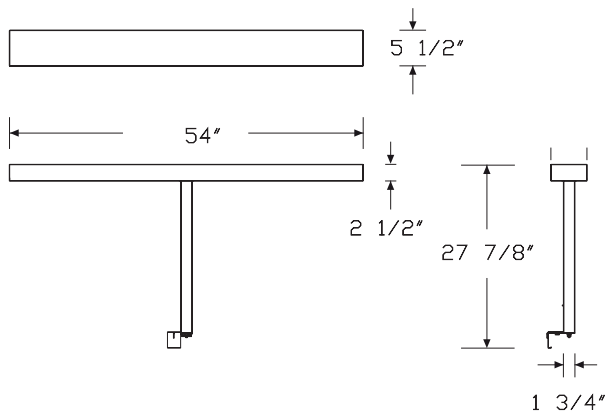

### Specification Information

#### Step 1.

**FG600.** \$1824

#### Step 2. Finish

##### Smooth Paint

<b>91</b>	white	+\$0
<b>98</b>	studio white	+\$0
<b>SNA</b>	satin aluminum	+\$0
<b>SNC</b>	satin carbon	+\$0

##### Metallic Paint

<b>CN</b>	metallic champagne	+\$0
<b>MS</b>	metallic silver	+\$0

##### Sand Texture Paint

<b>BK</b>	black	+\$0
<b>G1</b>	graphite	+\$0

# Chase Shelf

FGS17.

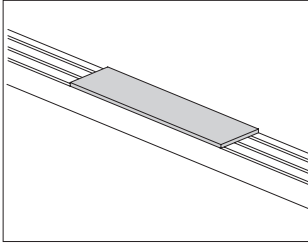

## Product Information

**Description**  
 This surface attaches to the top of a Canvas Vista™ chase to provide a platform for user accessories. It has a laminate top with thermoplastic edge, laminate top with thermoplastic backed plywood edge, or veneer top and edge. Laminate and veneer surfaces are 3/4" thick. Attachment hardware included.

**Notes**  
 Surface can be mounted anywhere along the top of the case and is user movable.  
 For additional product options, see Vary Easy Program in appendices.

## Dimensions

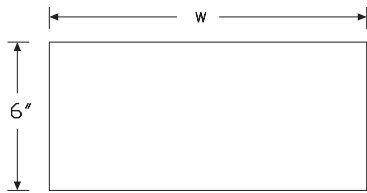

Canvas Vista™ Accessories

## Specification Information

**Step 1.**

**FG**

**Step 2. Edge**

**S17.** squared edge

**Step 3. Depth**

**06** 6" deep

**Step 4. Width**

**18** 18" wide

**24** 24" wide

**Step 5. Surface Material**

**L** laminate top/thermoplastic edge

**U** laminate top/universal edge

**W** veneer top/veneer edge A

Prices for Steps 1-5.

	L	U	W
<b>FGS17. 06 18</b>	\$213	213	279
<b>24</b>	\$243	243	309

Step 6.

Top Finish

*For laminate top/thermoplastic edge (L) or laminate top/universal edge (U)*

<b>76</b>	light brown walnut	+\$0
<b>8Q</b>	folkstone grey	+\$0
<b>91</b>	white	+\$0
<b>98</b>	studio white	+\$0
<b>CL</b>	cool grey neutral	+\$0
<b>G1</b>	graphite	+\$0
<b>HM</b>	natural maple	+\$0
<b>HP</b>	light anigre	+\$0
<b>HX</b>	aged cherry	+\$0
<b>HY</b>	walnut on cherry	+\$0
<b>LA</b>	light ash	+\$0
<b>LBA</b>	clear on ash	+\$0
<b>LBB</b>	oak on ash	+\$0
<b>LBC</b>	walnut on ash	+\$0
<b>LBD</b>	dark brown walnut	+\$0
<b>LBF</b>	neutral twill	+\$0
<b>LBG</b>	sarum twill	+\$0
<b>LBH</b>	earthen twill	+\$0
<b>LBJ</b>	graphite twill	+\$0
<b>LBK</b>	pewter mesh	+\$0
<b>LBL</b>	steel mesh	+\$0
<b>LBM</b>	crisp linen	+\$0
<b>LBN</b>	classic linen	+\$0
<b>LBP</b>	casual linen	+\$0
<b>LBQ</b>	white twill	+\$0
<b>LU</b>	soft white	+\$0
<b>WL</b>	sandstone	+\$0
<b>WN</b>	warm grey neutral	+\$0

Top/Edge Finish

*For veneer top/veneer edge (W)*

<b>2U</b>	light brown walnut	+\$60
<b>40</b>	dark brown walnut	+\$60
<b>ED</b>	aged cherry	+\$60
<b>EK</b>	medium red walnut	+\$60
<b>ET</b>	clear on ash	+\$60
<b>EU</b>	oak on ash	+\$60
<b>EV</b>	walnut on ash	+\$60
<b>EW</b>	medium matte walnut	+\$60
<b>UL</b>	natural maple	+\$60
<b>UX</b>	walnut on cherry	+\$60

Step 7. Edge Finish

*For laminate top/thermoplastic edge (L)*

<b>76</b>	light brown walnut	+\$0
<b>8Q</b>	folkstone grey	+\$0
<b>91</b>	white	+\$0
<b>98</b>	studio white	+\$0
<b>BU</b>	black umber	+\$0
<b>CL</b>	cool grey neutral	+\$0
<b>HF</b>	inner tone light	+\$0
<b>HM</b>	natural maple	+\$0
<b>HP</b>	light anigre	+\$0
<b>HT</b>	inner tone	+\$0
<b>HX</b>	aged cherry	+\$0
<b>HY</b>	walnut on cherry	+\$0
<b>LA</b>	light ash	+\$0
<b>LBA</b>	clear on ash	+\$0
<b>LBB</b>	oak on ash	+\$0
<b>LBC</b>	walnut on ash	+\$0
<b>LBD</b>	dark brown walnut	+\$0
<b>LBF</b>	neutral twill	+\$0
<b>LBG</b>	sarum twill	+\$0
<b>LBH</b>	earthen twill	+\$0
<b>LBJ</b>	graphite twill	+\$0
<b>LBK</b>	pewter mesh	+\$0
<b>LBL</b>	steel mesh	+\$0
<b>LBM</b>	crisp linen	+\$0
<b>LBN</b>	classic linen	+\$0
<b>LBP</b>	casual linen	+\$0
<b>LBQ</b>	white twill	+\$0
<b>LBU</b>	medium matte walnut	+\$0
<b>LU</b>	soft white	+\$0
<b>MT</b>	medium tone	+\$0
<b>WL</b>	sandstone	+\$0
<b>WN</b>	warm grey neutral	+\$0

*For laminate top/thermoplastic edge (L)*

<b>G1</b>	graphite	+\$0
-----------	----------	------

*For laminate top/universal edge (U)*

<b>PLY</b>	plywood edge	+\$50
------------	--------------	-------

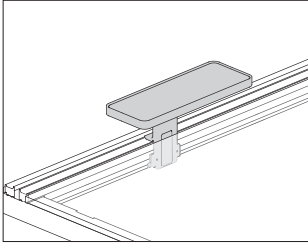

**Product Information**

**Description**

This painted metal shelf comes in 4 sizes and mounts to a surface along the back edge, to a Layout Studio® performance rail or a Canvas Vista™ chase. All attachment types are user movable without tools. The backdrop is optional, and can be easily retrofitted in the field. Backdrop and rod finish match shelf finish. When attached to a surface along the back edge or a Layout Studio performance rail, the space under the shelf can accommodate accessory boxes. Shelf comes with a liner in a choice of colors.

**Notes**

Changing the attachment type on an existing shelf is not easily completed in the field.

Order the following accessories separately:

- Name tag (YT410.)
- USB power module (YT420.)
- Rod bookend (YT440.) for 8" shelf depth only
- Short bin (YT800.)
- Small box (YT840.S)
- Square pencil cup (YT820.)
- Round pencil cup (YT825.)
- Shelf liner (YT510.)

Shelf and backdrop are not recommended for use on Public Office Landscape® desks (BVD1.) in the back-to-back configuration.

Vista chase mount (C) attaches to the Canvas Vista Chase (FG110.).

Attachment hardware included. For additional information, see Canvas Vista planning guide.

Canvas Vista™ Accessories

**Dimensions**

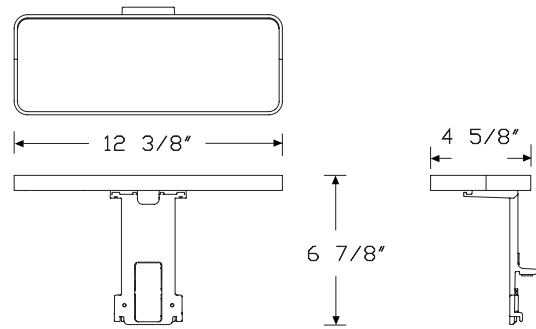

(R) Rail mount stanchion for layout studio performance rail

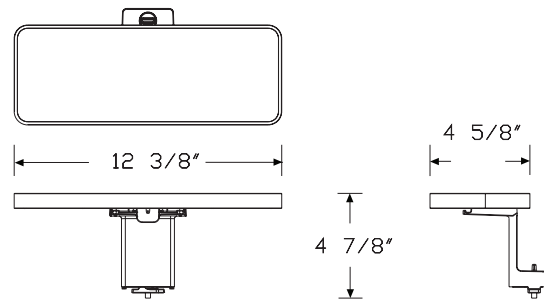

(C) Vista chase mount

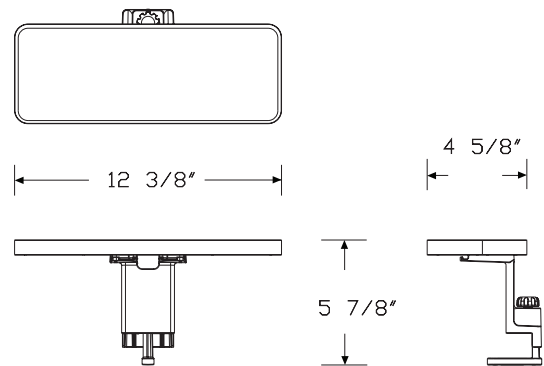

(S) Surface clamp stanchion

Shelf *continued*

**Specification Information**

Step 1.

**YT300.**  A

Step 2. Height

**04** 4" high  A

Step 3. Width

**12** 12" wide  A

**15** 15" wide  A

**22** 22" wide  A

Step 4. Depth

*For 12" wide (12)*

**05** 5" deep  A

*For 15" wide (15)*

**08** 8" deep  A

*For 22" wide (22)*

**05** 5" deep  A

**08** 8" deep  A

Step 5. Attachment Type

**S** surface clamp stanchion  A

**R** rail mount stanchion for Layout Studio Performance Rail  A

**C** chase mount  A

Step 6. Backdrop

**N** no backdrop  A

**B** backdrop  A

Step 7. Shelf Material

**M** painted metal  A

**L** insert liner  A

Prices for Steps 1-7.

	05SNM	05SNL	05SBM	05SBL	05RNM	05RNL
<b>YT300. 04 12</b>	\$191	250	287	345	191	250
<b>22</b>	\$228	313	350	434	228	313

	05RBM	05RBL	05CNM	05CNL	05CBM	05CBL
<b>YT300. 04 12</b>	\$287	345	206	262	295	352
<b>22</b>	\$350	434	263	342	379	458

	08SNM	08SNL	08SBM	08SBL	08RNM	08RNL
<b>YT300. 04 15</b>	\$208	273	313	377	208	273
<b>22</b>	\$246	335	369	457	246	335

	08RBM	08RBL	08CNM	08CNL	08CBM	08CBL
<b>YT300. 04 15</b>	\$313	377	220	282	320	382
<b>22</b>	\$369	457	281	366	396	481

Step 8. Shelf Finish

Metallic Paint

**MS** metallic silver  A +\$0

Sand Texture Paint

**BK** black  A +\$0

Smooth Paint

**91** white  A +\$0

**98** studio white  A +\$0

**G1** graphite  A +\$0

Step 9. Insert Liner Finish

*For insert liner (L)*

Price Category 4 +\$0

# Magnetic Document Clip

YT400.

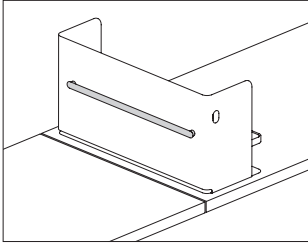

## Product Information

### Description

This document clip magnetically attaches to the back of the large and small organizers and the screen to provide storage for documents.

### Notes

Magnetic document clip fits on the following products, ordered separately:

- Small organizer (YT100.)
- Large organizer (YT150.)
- Slim screen (YT200.)

## Dimensions

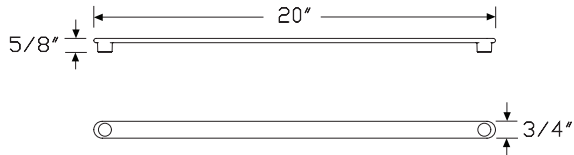

## Specification Information

### Step 1.

**YT400.**  A

### Step 2. Depth

**20** 20" deep  A

### Prices for Steps 1-2.

**YT400. 20** \$77

### Step 3. Finish

<b>91</b>	white <input type="checkbox"/> A	+\$0
<b>98</b>	studio white <input type="checkbox"/> A	+\$0
<b>BK</b>	black <input type="checkbox"/> A	+\$0
<b>G1</b>	graphite <input type="checkbox"/> A	+\$0
<b>MS</b>	metallic silver <input type="checkbox"/> A	+\$0

# Bag Hook

YT700.

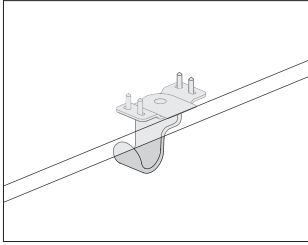

## Product Information

### Description

This bag hook clamps to a work surface, mounts under the surface with screws or mounts to the underside of the Canvas Vista™ chase. The hook rotates 360° to hold the bag under the surface. Clamp mount is easily moved by the user. Fixed attachment option includes attachment hardware.

### Notes

Clamp attaches to work surfaces from 3/4" to 1 1/8" thick.

Maximum weight capacity is 15 pounds for clamp and fixed attachment.

Vista chase mount (M) attaches to the underside of the Canvas Vista chase (FG110). Attachment hardware included. It is user movable. For additional information, see Canvas Vista planning guide.

## Dimensions

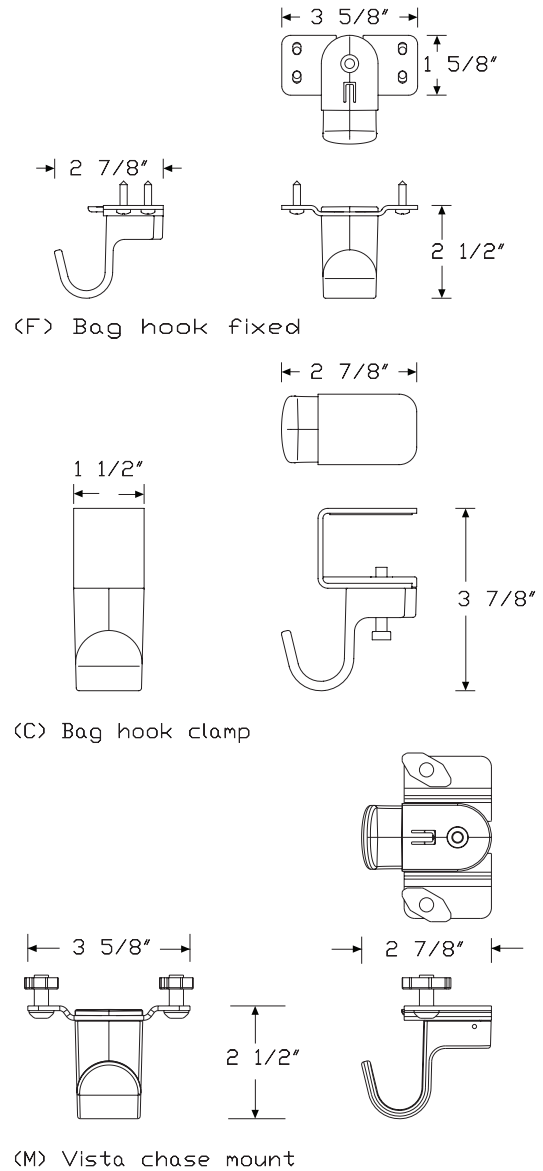

# Bag Hook *continued*

## Specification Information

Step 1.

**YT700.**  A

Step 2. Attachment Type

**C** clamp  A

**F** fixed  A

**M** chase mount  A

Prices for Steps 1-2.

<b>YT700. C</b>	\$50
<b>F</b>	\$50
<b>M</b>	\$48

Step 3. Finish

**91** white  A +\$0

**98** studio white  A +\$0

**BK** black  A +\$0

**G1** graphite  A +\$0

**MS** metallic silver  A +\$0

# Motia® Vista™ Rectangular Table with T-Foot DV6GTS

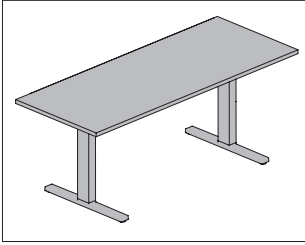

## Product Information

### Description

This rectangular height adjustable table has a T-leg configuration and laminate top with square thermoplastic edge, laminate top with thermoplastic backed plywood edge or veneer top and edge. Multiple height adjustment options come with a simple up/down touch switch, simple up/down paddle switch or with no switch to accommodate adding Live Platform™ to the table. Glides have 1/2" leveling range. Work surface stiffener included. Shipped knocked down. Product is UL Listed.

### Notes

Floor to top-of-surface height adjustment ranges are 27"-46" for the electric standard range (E) option, and 22"-48" for the electric extended range (D) option.

Sizes listed for table depth and width are nominal. Depth of surface is reduced by 1" for cord management. Width of surface is reduced 2" to minimize possible pinch point hazards.

When no under-surface mounted storage (L2SCF., L2SDF.) is used, specify legs outbound (1) location.

To use under-surface mounted storage (L2SCF., L2SDF.) on both ends of the surface, specify legs inbound for under surface storage on both ends (2) location.

To use under-surface mounted storage (L2SCF., L2SDF.) on the right- or left-hand end of the surface, specify legs inbound for under surface storage on left or right end (3) location. This will make the table handed. Surface will come with inbound leg holes; the outbound leg holes will need to be field drilled.

Table includes stiffener.

When specifying cable trough (2, 3), trough finish will match table base finish.

When specifying a power access cutout (RC, LC, CC), Logic Mini unit (Y1414.) and grommet (Y1412.) must be ordered separately.

When specifying a 24"D x 54"W table with legs inbound for under surface storage on both ends (2) option, the hinged cable trough option is not available. It is recommended to use the (Y1200.48N) cable trough, ordered separately.

Order the following optional products separately:

- Vista modesty + privacy screen-double sided, height adjustable table (Y1130.)
- Vista modesty screen-double sided, height adjustable table (Y1131.)
- Suspended cubby (L2SCF.)
- Suspended drawer (L2SDF.)

For additional planning information, see planning guide.

For additional product options, see Vary Easy Program in appendices.

## Dimensions

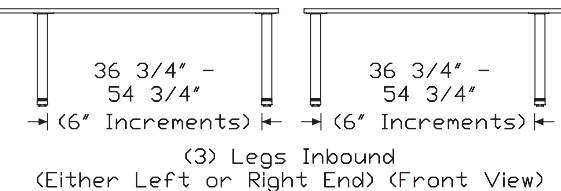
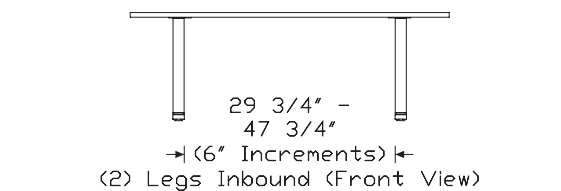
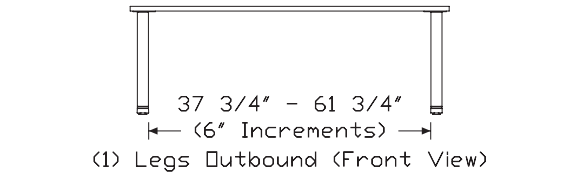
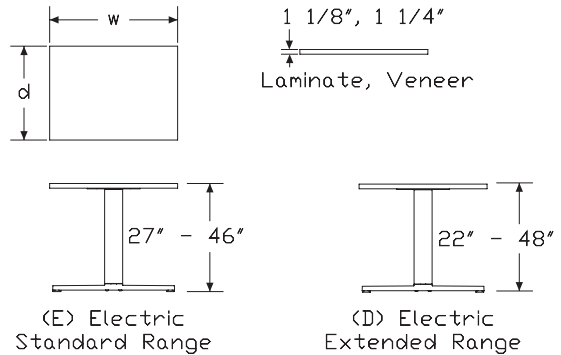

Canvas Vista™ Height Adjustable Table

# Motia® Vista™ Rectangular Table with T-Foot *continued*

Canvas Vista™ Height Adjustable Table

## Specification Information

Step 1.

**DV6GT** A

Step 2. Edge

**S.** squared-edge A

Step 3. Depth

**24** 24" deep (23" surface size) A

**30** 30" deep (29" surface size) A

Step 4. Width

**48** 48" wide (46" surface size) A

**54** 54" wide (52" surface size) A

**60** 60" wide (58" surface size) A

**66** 66" wide (64" surface size) A

**72** 72" wide (70" surface size) A

Step 5. Surface Material

**L** laminate top/thermoplastic edge A

**U** laminate top/universal edge A

**W** veneer top/veneer edge A

Step 6. Top Thickness

**04** 1¼" thick A

**08** 1⅝" thick A

Step 7. Mechanism

**D** electric extended range A

**E** electric standard range A

Step 8. Leg Location

*For 48" wide (46" surface size) (48) with electric extended range (D) or electric standard range (E)*

**1** legs outbound (no surface mounted storage) A

*For 54" wide (52" surface size) (54), 60" wide (58" surface size) (60), 66" wide (64" surface size) (66), or 72" wide (70" surface size) (72) with electric standard range (E)*

**1** legs outbound (no surface mounted storage) A

**2** legs inbound (for under surface storage on both ends) A

**3** legs inbound (for under surface storage on left or right end) A

*For 54" wide (52" surface size) (54), 60" wide (58" surface size) (60), 66" wide (64" surface size) (66), or 72" wide (70" surface size) (72) with electric extended range (D)*

**1** legs outbound (no surface mounted storage) A

Prices for Steps 1-8.

	L04D1	L04E1	L04E2	L04E3	L08D1	L08E1
<b>DV6GTS. 24 48</b>	\$2498	2315	—	—	2556	2373
<b>54</b>	\$2565	2382	2382	2382	2624	2441
<b>60</b>	\$2611	2427	2427	2427	2669	2486
<b>66</b>	\$2672	2489	2489	2489	2730	2547
<b>72</b>	\$2731	2548	2548	2548	2790	2606
<b>30 48</b>	\$2510	2327	—	—	2569	2385
<b>54</b>	\$2593	2410	2410	2410	2651	2468
<b>60</b>	\$2645	2462	2462	2462	2704	2520
<b>66</b>	\$2725	2541	2541	2541	2784	2599
<b>72</b>	\$2801	2618	2618	2618	2859	2676

	L08E2	L08E3	U04D1	U04E1	U04E2	U04E3
<b>DV6GTS. 24 48</b>	—	—	\$2498	2315	—	—
<b>54</b>	\$2441	2441	2565	2382	2382	2382
<b>60</b>	\$2486	2486	2611	2427	2427	2427
<b>66</b>	\$2547	2547	2672	2489	2489	2489
<b>72</b>	\$2606	2606	2731	2548	2548	2548
<b>30 48</b>	—	—	\$2510	2327	—	—
<b>54</b>	\$2468	2468	2593	2410	2410	2410
<b>60</b>	\$2520	2520	2645	2462	2462	2462
<b>66</b>	\$2599	2599	2725	2541	2541	2541
<b>72</b>	\$2676	2676	2801	2618	2618	2618

	U08D1	U08E1	U08E2	U08E3	W04D1	W04E1
<b>DV6GTS. 24 48</b>	\$2556	2373	—	—	2872	2687
<b>54</b>	\$2624	2441	2441	2441	2985	2802
<b>60</b>	\$2669	2486	2486	2486	3083	2898
<b>66</b>	\$2730	2547	2547	2547	3198	3014
<b>72</b>	\$2790	2606	2606	2606	3293	3109
<b>30 48</b>	\$2569	2385	—	—	2976	2793
<b>54</b>	\$2651	2468	2468	2468	3116	2933
<b>60</b>	\$2704	2520	2520	2520	3243	3060
<b>66</b>	\$2784	2599	2599	2599	3391	3208
<b>72</b>	\$2859	2676	2676	2676	3514	3330

Motia® Vista™ Rectangular Table  
with T-Foot *continued*

	W04E2	W04E3	W08D1	W08E1	W08E2	W08E3
<b>DV6GTS. 24 48</b>	—	—	\$2930	2746	—	—
<b>54</b>	\$2802	2802	3044	2860	2860	2860
<b>60</b>	\$2898	2898	3141	2957	2957	2957
<b>66</b>	\$3014	3014	3257	3072	3072	3072
<b>72</b>	\$3109	3109	3351	3168	3168	3168
<b>30 48</b>	—	—	\$3035	2851	—	—
<b>54</b>	\$2933	2933	3175	2991	2991	2991
<b>60</b>	\$3060	3060	3302	3118	3118	3118
<b>66</b>	\$3208	3208	3449	3266	3266	3266
<b>72</b>	\$3330	3330	3572	3389	3389	3389

Step 9. Switch Option

<b>STS</b>	simple up/down - touch switch <input type="checkbox"/>	+\$0
<b>SUD</b>	simple up down - paddle switch <input type="checkbox"/>	+\$50
<b>SMT</b>	no switch - LO100 <input type="checkbox"/>	+\$0

Step 10.

Top Finish

For laminate top/thermoplastic edge (L) or laminate top/universal edge (U)

<b>76</b>	light brown walnut <input type="checkbox"/>	+\$0
<b>8Q</b>	folkstone grey <input type="checkbox"/>	+\$0
<b>91</b>	white <input type="checkbox"/>	+\$0
<b>98</b>	studio white <input type="checkbox"/>	+\$0
<b>CL</b>	cool grey neutral <input type="checkbox"/>	+\$0
<b>HF</b>	inner tone light <input type="checkbox"/>	+\$0
<b>HM</b>	natural maple <input type="checkbox"/>	+\$0
<b>HP</b>	light anigre <input type="checkbox"/>	+\$0
<b>HT</b>	inner tone <input type="checkbox"/>	+\$0
<b>HX</b>	aged cherry <input type="checkbox"/>	+\$0
<b>HY</b>	walnut on cherry <input type="checkbox"/>	+\$0
<b>LA</b>	light ash <input type="checkbox"/>	+\$0
<b>LBA</b>	clear on ash <input type="checkbox"/>	+\$0
<b>LBB</b>	oak on ash <input type="checkbox"/>	+\$0
<b>LBC</b>	walnut on ash <input type="checkbox"/>	+\$0
<b>LBD</b>	dark brown walnut <input type="checkbox"/>	+\$0
<b>LBF</b>	neutral twill <input type="checkbox"/>	+\$0
<b>LBG</b>	sarum twill <input type="checkbox"/>	+\$0
<b>LBH</b>	earthen twill <input type="checkbox"/>	+\$0
<b>LBJ</b>	graphite twill <input type="checkbox"/>	+\$0
<b>LBM</b>	crisp linen <input type="checkbox"/>	+\$0
<b>LBN</b>	classic linen <input type="checkbox"/>	+\$0
<b>LBP</b>	casual linen <input type="checkbox"/>	+\$0
<b>LBQ</b>	white twill <input type="checkbox"/>	+\$0
<b>LBR</b>	phantom ecru <input type="checkbox"/>	+\$0
<b>LBS</b>	phantom cocoa <input type="checkbox"/>	+\$0
<b>LBU</b>	medium matte walnut <input type="checkbox"/>	+\$0
<b>LBV</b>	warm grey teak <input type="checkbox"/>	+\$0
<b>LT</b>	light tone <input type="checkbox"/>	+\$0
<b>LU</b>	soft white <input type="checkbox"/>	+\$0
<b>MT</b>	medium tone <input type="checkbox"/>	+\$0
<b>WL</b>	sandstone <input type="checkbox"/>	+\$0
<b>WN</b>	warm grey neutral <input type="checkbox"/>	+\$0

Top Finish

For laminate top/thermoplastic edge (L) or laminate top/universal edge (U)

<b>OG</b>	honey maple <input type="checkbox"/>	+\$0
-----------	--------------------------------------	------

# Motia® Vista™ Rectangular Table with T-Foot *continued*

Top/Edge Finish		
<i>For veneer top/veneer edge (W)</i>		
<b>2U</b>	light brown walnut <input type="checkbox"/>	+\$85
<b>40</b>	dark brown walnut <input type="checkbox"/>	+\$85
<b>ED</b>	aged cherry <input type="checkbox"/>	+\$85
<b>EK</b>	medium red walnut <input type="checkbox"/>	+\$85
<b>ET</b>	clear on ash <input type="checkbox"/>	+\$85
<b>EU</b>	oak on ash <input type="checkbox"/>	+\$85
<b>EV</b>	walnut on ash <input type="checkbox"/>	+\$85
<b>EW</b>	medium matte walnut <input type="checkbox"/>	+\$85
<b>UL</b>	natural maple <input type="checkbox"/>	+\$85
<b>UX</b>	walnut on cherry <input type="checkbox"/>	+\$85

### Step 11. Edge Finish

<i>For laminate top/thermoplastic edge (L)</i>		
<b>76</b>	light brown walnut <input type="checkbox"/>	+\$0
<b>8Q</b>	folkstone grey <input type="checkbox"/>	+\$0
<b>91</b>	white <input type="checkbox"/>	+\$0
<b>98</b>	studio white <input type="checkbox"/>	+\$0
<b>BU</b>	black umber <input type="checkbox"/>	+\$0
<b>CL</b>	cool grey neutral <input type="checkbox"/>	+\$0
<b>HF</b>	inner tone light <input type="checkbox"/>	+\$0
<b>HM</b>	natural maple <input type="checkbox"/>	+\$0
<b>HP</b>	light anigre <input type="checkbox"/>	+\$0
<b>HT</b>	inner tone <input type="checkbox"/>	+\$0
<b>HX</b>	aged cherry <input type="checkbox"/>	+\$0
<b>HY</b>	walnut on cherry <input type="checkbox"/>	+\$0
<b>LA</b>	light ash <input type="checkbox"/>	+\$0
<b>LBA</b>	clear on ash <input type="checkbox"/>	+\$0
<b>LBB</b>	oak on ash <input type="checkbox"/>	+\$0
<b>LBC</b>	walnut on ash <input type="checkbox"/>	+\$0
<b>LBD</b>	dark brown walnut <input type="checkbox"/>	+\$0
<b>LBF</b>	neutral twill <input type="checkbox"/>	+\$0
<b>LBG</b>	sarum twill <input type="checkbox"/>	+\$0
<b>LBH</b>	earthen twill <input type="checkbox"/>	+\$0
<b>LBJ</b>	graphite twill <input type="checkbox"/>	+\$0
<b>LBK</b>	pewter mesh <input type="checkbox"/>	+\$0
<b>LBL</b>	steel mesh <input type="checkbox"/>	+\$0
<b>LBM</b>	crisp linen <input type="checkbox"/>	+\$0
<b>LBN</b>	classic linen <input type="checkbox"/>	+\$0
<b>LBP</b>	casual linen <input type="checkbox"/>	+\$0
<b>LBQ</b>	white twill <input type="checkbox"/>	+\$0
<b>LBR</b>	phantom ecru <input type="checkbox"/>	+\$0
<b>LBS</b>	phantom cocoa <input type="checkbox"/>	+\$0
<b>LBU</b>	medium matte walnut <input type="checkbox"/>	+\$0
<b>LBV</b>	warm grey teak <input type="checkbox"/>	+\$0

<b>LU</b>	soft white <input type="checkbox"/>	+\$0
<b>MT</b>	medium tone <input type="checkbox"/>	+\$0
<b>WL</b>	sandstone <input type="checkbox"/>	+\$0
<b>WN</b>	warm grey neutral <input type="checkbox"/>	+\$0

<i>For laminate top/thermoplastic edge (L)</i>		
<b>OG</b>	honey maple <input type="checkbox"/>	+\$0

<i>For laminate top/universal edge (U)</i>		
<b>PLY</b>	plywood edge <input type="checkbox"/>	+\$50

### Step 12. Base Finish

Smooth Paint		
<b>8Q</b>	folkstone grey <input type="checkbox"/>	+\$0
<b>91</b>	white <input type="checkbox"/>	+\$0
<b>98</b>	studio white <input type="checkbox"/>	+\$0
<b>CL</b>	cool grey neutral <input type="checkbox"/>	+\$0
<b>WL</b>	sandstone <input type="checkbox"/>	+\$0
<b>WN</b>	warm grey neutral <input type="checkbox"/>	+\$0

Metallic Paint		
<b>CN</b>	metallic champagne <input type="checkbox"/>	+\$0
<b>EH</b>	metallic bronze <input type="checkbox"/>	+\$0
<b>MS</b>	metallic silver <input type="checkbox"/>	+\$0

Sand Texture Paint		
<b>BK</b>	black <input type="checkbox"/>	+\$0
<b>G1</b>	graphite <input type="checkbox"/>	+\$0

### Step 13. Cable Trough

*For 24" deep (23" surface size) (24), legs outbound (no surface mounted storage) (1) AND legs inbound (for under surface storage on left or right end) (3)*

<b>2</b>	hinged cable trough for 24" deep surface <input type="checkbox"/>	+\$275
<b>N</b>	no cable trough <input type="checkbox"/>	+\$0

*For 30" deep (29" surface size) (30) with 48" wide (46" surface size) (48), 54" wide (52" surface size) (54), 60" wide (58" surface size) (60), or 66" wide (64" surface size) (66), or 72" wide (70" surface size) (72)*

<b>3</b>	hinged cable trough for 30" deep surface <input type="checkbox"/>	+\$296
<b>N</b>	no cable trough <input type="checkbox"/>	+\$0

*For 24" deep (23" surface size) (24) with 54" wide (52" surface size) (54) with legs inbound (for under surface storage on both ends) (2)*

<b>N</b>	no cable trough <input type="checkbox"/>	+\$0
----------	--	------

# Motia® Vista™ Rectangular Table with T-Foot *continued*

---

## Step 14. Power Access Cutout

<b>CC</b>	center cutout for Logic Mini - <input type="checkbox"/> A	+\$55
<b>LC</b>	left cutout for Logic Mini - Y1414 and Y1412 <input type="checkbox"/> A	+\$55
<b>NC</b>	no cutout <input type="checkbox"/> A	+\$0
<b>RC</b>	right cutout for Logic Mini - Y1414 and Y1412 <input type="checkbox"/> A	+\$55

---

## Step 15. Glides

<b>57</b>	glides <input type="checkbox"/> A	+\$0
-----------	-----------------------------------	------

# Motia® Vista™ Adjustable Base Kit DV7GT. with T-Foot

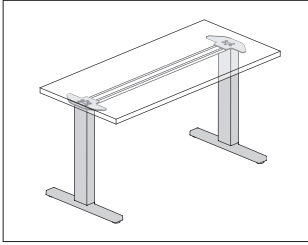

## Product Information

### Description

This independent 2-leg kit converts existing work surfaces into height adjustable tables. Legs come in 2 depths and multiple widths with a choice of switch type. Glides have 1/2" of leveling range. Kit includes work surface stiffener. Shipped knocked down. Product is UL Recognized.

### Notes

With standard 1 1/8" thick work surface, floor to top-of-surface height adjustment ranges are 27"-46" for the electric standard range (E) option, and 22"-48" for the electric extended range (D) option.

Sizes listed for foot depth and base width are nominal. Depth of foot is reduced 1" for cord management when paired with equal depth work surface. Width of base is reduced 2" to minimize possible pinch point hazards when paired with equal width work surface.

To accommodate adding Live Platform™ to the table, specify no switch - LO100 (SMT) option.

For proper installation of leg kit and design information, see planning guide.

## Dimensions

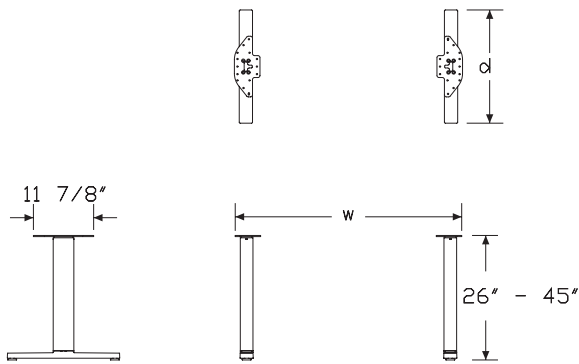

(E) Electric Standard Range

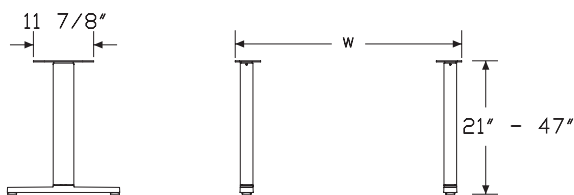

(D) Electric Extended Range

## Specification Information

### Step 1.

**DV7GT.** [A]

### Step 2. Depth

**24** 24" deep (23" surface size) [A]  
**30** 30" deep (29" surface size) [A]

### Step 3. Mechanism

**D** electric extended range [A]  
**E** electric standard range [A]

### Step 4. Leg Location

**1** legs outbound (no surface mounted storage) [A]

### Prices for Steps 1-4.

	<b>1</b>
<b>DV7GT. 24 D</b>	\$2235
<b>E</b>	\$2051
<b>30 D</b>	\$2166
<b>E</b>	\$1983

### Step 5. Switch Option

<b>STS</b> simple up/down touch switch [A]	+\$0
<b>SMT</b> no switch - LO100 [A]	+\$0
<b>SUD</b> simple up down - paddle switch [A]	+\$50
<b>SRM</b> digital read out with memory [A]	+\$160

### Step 6. Leg/Foot Finish

#### Smooth Paint

<b>8Q</b> folkstone grey [A]	+\$0
<b>91</b> white [A]	+\$0
<b>98</b> studio white [A]	+\$0
<b>CL</b> cool grey neutral [A]	+\$0
<b>WL</b> sandstone [A]	+\$0
<b>WN</b> warm grey neutral [A]	+\$0

#### Metallic Paint

<b>CN</b> metallic champagne [A]	+\$0
<b>EH</b> metallic bronze [A]	+\$0
<b>MS</b> metallic silver [A]	+\$0

#### Sand Texture Paint

<b>BK</b> black [A]	+\$0
<b>G1</b> graphite [A]	+\$0

# Motia® Vista™ Adjustable Base Kit with T-Foot *continued*

---

Step 7. Glides

57 glides  +\$0

Vista Privacy + Modesty Screen - Y1130.  
Double Sided, Height Adjustable  
Table

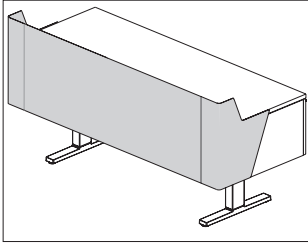

**Product Information**

**Description**

This sheet metal privacy + modesty screen attaches to a Motia® Vista™ height adjustable table. The screen wraps around both ends of the work surface. Attachment hardware included.

**Notes**

Actual screen width is 2" less than specified width.  
Privacy top edge is 7" above top of work surface at a 36" datum height.  
Bottom edge of screen is 15" below top of work surface.  
Recommended mounting creates a 1" gap between back edge of surface and the screen to accommodate cable routing and the attachment or clamp-mounting of other hardware to the surface.  
There is not enough clearance for an open frame screen (FG345.) to be mounted above the work surface.

**Dimensions**

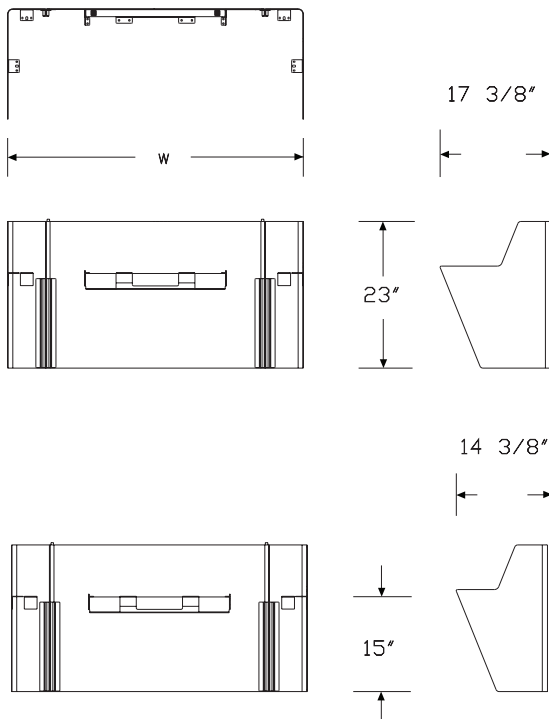

Canvas Vista™ Height Adjustable Table

**Specification Information**

**Step 1.**

**Y1130.** [A]

**Step 2. Height**

**A36** 36" high/15" below work surface [A]

**Step 3. Depth**

**24** 24" deep [A]

**30** 30" deep [A]

**Step 4. Width**

**48** 48" wide [A]

**54** 54" wide [A]

**60** 60" wide [A]

**66** 66" wide [A]

**72** 72" wide [A]

**Prices for Steps 1-4.**

		48	54	60	66	72
<b>Y1130. A36</b>	<b>24</b>	\$746	777	807	845	894
	<b>30</b>	\$780	811	842	885	928

**Step 5. Screen Finish**

**Smooth Paint**

<b>8Q</b>	folkstone grey [A]	+\$0
<b>91</b>	white [A]	+\$0
<b>98</b>	studio white [A]	+\$0
<b>CL</b>	cool grey neutral [A]	+\$0
<b>WL</b>	sandstone [A]	+\$0
<b>WN</b>	warm grey neutral [A]	+\$0

**Metallic Paint**

<b>CN</b>	metallic champagne [A]	+\$0
<b>EH</b>	metallic bronze [A]	+\$0
<b>MS</b>	metallic silver [A]	+\$0

**Sand Texture Paint**

<b>BK</b>	black [A]	+\$0
<b>G1</b>	graphite [A]	+\$0

# Vista Modesty Screen - Double Sided, Height Adjustable Table

Y1131.

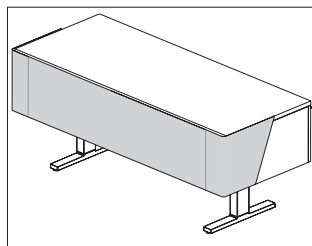

### Product Information

#### Description

This sheet metal modesty screen attaches to a Motia® Vista™ height adjustable table. The screen wraps around both ends of the work surface. Attachment hardware included.

#### Notes

- Actual screen width is 2" less than specified width.
- Bottom edge of screen is 15" below top of work surface.
- Recommended mounting creates a 1" gap between back edge of surface and the screen to accommodate cable routing and the attachment or clamp-mounting of other hardware to the surface.
- There is enough clearance for an open frame screen (FG345.) to be mounted above the work surface. Order separately.

#### Dimensions

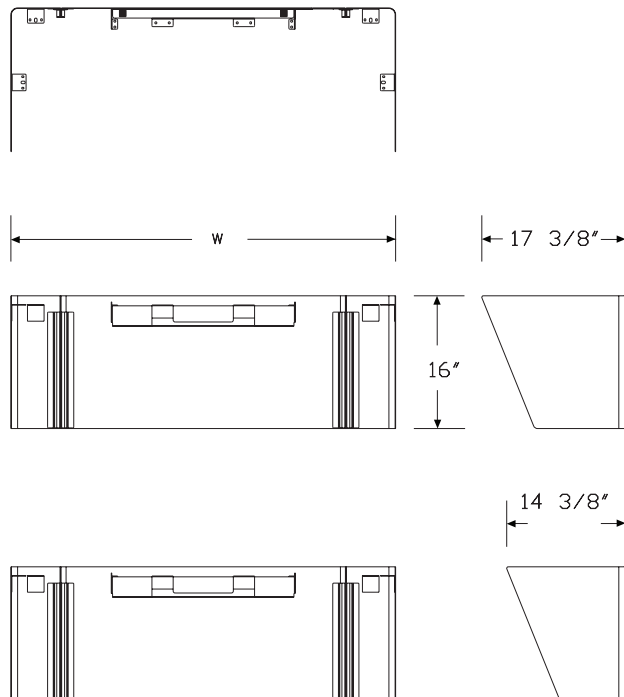

### Specification Information

#### Step 1.

**Y1131.** [A]

#### Step 2. Depth

**24** 24" deep [A]

**30** 30" deep [A]

#### Step 3. Width

**48** 48" wide [A]

**54** 54" wide [A]

**60** 60" wide [A]

**66** 66" wide [A]

**72** 72" wide [A]

#### Prices for Steps 1-3.

	48	54	60	66	72
<b>Y1131. 24</b>	\$607	621	634	692	749
<b>30</b>	\$628	641	654	712	770

#### Step 4. Screen Finish

##### Smooth Paint

<b>8Q</b>	folkstone grey [A]	+\$0
<b>91</b>	white [A]	+\$0
<b>98</b>	studio white [A]	+\$0
<b>CL</b>	cool grey neutral [A]	+\$0
<b>WL</b>	sandstone [A]	+\$0
<b>WN</b>	warm grey neutral [A]	+\$0

##### Metallic Paint

<b>CN</b>	metallic champagne [A]	+\$0
<b>EH</b>	metallic bronze [A]	+\$0
<b>MS</b>	metallic silver [A]	+\$0

##### Sand Texture Paint

<b>BK</b>	black [A]	+\$0
<b>G1</b>	graphite [A]	+\$0

Canvas Vista™ Height Adjustable Table

# Pari Screen, Height Adjustable Tables

Y1116.

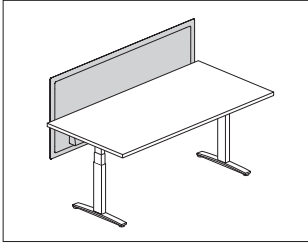

## Product Information

### Description

This screen attaches to an individual height adjustable work surface. It has an all-fabric, tackable surface with frameless design, and comes in privacy and modesty sizes. Attachment hardware included.

### Notes

Privacy and modesty panel actual width is 2" less than specified width.

Privacy screen (A) top edge aligns with the 42" high Canvas datum line; bottom edge is 4" below work surface.

Privacy & modesty screen (B) top edge aligns with the 42" high Canvas datum line; bottom edge is 10" below work surface.

Privacy screen (C) top edge aligns with the 46" high Canvas datum line; bottom edge is 4" below work surface.

Privacy & modesty screen (D) top edge aligns with the 46" high Canvas datum line; bottom edge is 10" below work surface.

Privacy screen (E) top edge aligns with the 53" high Canvas datum line; bottom edge is 4" below work surface.

Privacy & modesty screen (F) top edge aligns with the 53" high Canvas datum line; bottom edge is 10" below work surface.

Screens 54" wide and wider include an additional 1"-wide center mounting bracket.

Recommended mounting creates a 1" gap between back edge of surface and the screen to accommodate cable routing and the attachment or clamp-mounting of other hardware to the surface.

Optional cable management trough is only available when specifying privacy & modesty height option (B). Trough finish is graphite.

Attachment brackets are inset from edge of screen by approximately 8" and require 2½" of work surface for attachment.

Attachment bracket finish is painted graphite.

Screen accepts Customer's Own Material (COM). Yardage is estimated for nondirectional 54"-wide fabrics.

For vertical fabric direction (T):

Height—Yardage

A—1.51

B—1.89

C—1.76

D—2.14

E—2.21

F—2.58

For horizontal fabric direction (R):

Width—Yardage

For heights A/B:

24—0.88

30—1.07

36—1.26

42—1.45

48—1.64

54—1.83

60—2.02

66—2.21

72—2.39

For heights C/D/E/F:

24—1.76

30—2.14

36—2.52

42—2.90

48—3.28

54—3.65

60—4.03

66—4.41

72—4.79

For information on multiple quantities or directional fabrics, contact COM Department. See Order Information in Appendices.

## Dimensions

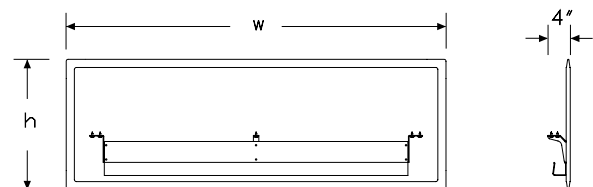

# Pari Screen, Height Adjustable Tables *continued*

## Specification Information

Step 1.

**Y1116.** A

Step 2. Height

- A** privacy (42" high) A
- B** privacy & modesty (42" high/10" below surface) A
- C** privacy (46" high) A
- D** privacy & modesty (46" high/10" below surface) A
- E** privacy (53" high) A
- F** privacy & modesty (53" high/10" below surface) A

Step 3. Width

- 24** 24" wide A
- 30** 30" wide A
- 36** 36" wide A
- 42** 42" wide A
- 48** 48" wide A
- 54** 54" wide A
- 60** 60" wide A
- 66** 66" wide A
- 72** 72" wide A

Step 4. Surface Material

*For 24" wide (24), 30" wide (30), 36" wide (36), 42" wide (42), or 48" wide (48)*

- R** tackable fabric, horizontal A
- T** tackable fabric A

*For 54" wide (54), 60" wide (60), 66" wide (66), or 72" wide (72)*

- R** tackable fabric, horizontal A

Prices for Steps 1-4.

		R	T
<b>Y1116. A</b>	<b>24</b>	\$448	448
	<b>30</b>	\$521	521
	<b>36</b>	\$541	541
	<b>42</b>	\$573	573
	<b>48</b>	\$594	594
	<b>54</b>	\$652	—
	<b>60</b>	\$701	—
	<b>66</b>	\$750	—
	<b>72</b>	\$790	—

<b>B</b>	<b>24</b>	\$542	542
	<b>30</b>	\$580	580
	<b>36</b>	\$616	616
	<b>42</b>	\$652	652
	<b>48</b>	\$724	724
	<b>54</b>	\$815	—
	<b>60</b>	\$836	—
	<b>66</b>	\$900	—
	<b>72</b>	\$923	—
<b>C</b>	<b>24</b>	\$509	509
	<b>30</b>	\$546	546
	<b>36</b>	\$584	584
	<b>42</b>	\$620	620
	<b>48</b>	\$684	684
	<b>54</b>	\$752	—
	<b>60</b>	\$839	—
	<b>66</b>	\$879	—
	<b>72</b>	\$915	—
<b>D</b>	<b>24</b>	\$654	654
	<b>30</b>	\$691	691
	<b>36</b>	\$727	727
	<b>42</b>	\$764	764
	<b>48</b>	\$822	822
	<b>54</b>	\$862	—
	<b>60</b>	\$913	—
	<b>66</b>	\$959	—
	<b>72</b>	\$984	—
<b>E</b>	<b>24</b>	\$671	671
	<b>30</b>	\$707	707
	<b>36</b>	\$744	744
	<b>42</b>	\$802	802
	<b>48</b>	\$826	826
	<b>54</b>	\$873	—
	<b>60</b>	\$890	—
	<b>66</b>	\$912	—
	<b>72</b>	\$933	—
<b>F</b>	<b>24</b>	\$738	738
	<b>30</b>	\$775	775
	<b>36</b>	\$812	812
	<b>42</b>	\$849	849
	<b>48</b>	\$914	914
	<b>54</b>	\$946	—
	<b>60</b>	\$981	—
	<b>66</b>	\$1061	—
	<b>72</b>	\$1082	—

Canvas Vista™ Height Adjustable Table

Pari Screen, Height Adjustable  
 Tables *continued*

Step 5. Cable Trough  
 For privacy & modesty (42" high/10" below surface) (B), privacy & modesty (46" high/10" below surface) (D), or privacy & modesty (53" high/10" below surface) (F)

<b>NC</b>	no cable way <input type="checkbox"/> A	+\$0
<b>CW</b>	cable way <input type="checkbox"/> A	+\$25

Step 6. Fabric

Price Category C	+\$101
Price Category 1	+\$0
Price Category 2	+\$19
Price Category 3	+\$41
Price Category 4	+\$80
Price Category E	+\$152

Canvas Vista™ Height Adjustable Table

# Surface-Attached Screen, Flat Edge

Y1118.

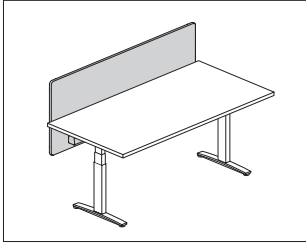

## Product Information

### Description

This surface-attached tackable screen attaches to an individual table, desk, or work surface. It has a frameless all-fabric design with a flat edge, and comes in privacy and modesty sizes. Attachment hardware included.

### Notes

Privacy and modesty panel actual width is 2" less than specified width.

Privacy screen (A) top edge is 13" above top of work surface; bottom edge is 3<sup>3</sup>/<sub>4</sub>" below work surface.

Privacy & modesty screen (B) top edge is 13" above top of work surface; bottom edge is 10" below work surface.

Privacy screen (A) top edge aligns with the 42" high Canvas datum line; bottom edge is 4" below work surface.

Privacy & modesty screen (B) top edge aligns with the 42" high Canvas datum line; bottom edge is 9" below work surface.

Privacy screen (C) top edge aligns with the 46" high Canvas datum line; bottom edge is 4" below work surface.

Privacy & modesty screen (D) top edge aligns with the 46" high Canvas datum line; bottom edge is 9" below work surface.

Privacy screen (E) top edge aligns with the 53" high Canvas datum line; bottom edge is 4" below work surface.

Privacy & modesty screen (F) top edge aligns with the 53" high Canvas datum line; bottom edge is 9" below work surface.

Screens 54" wide and wider include an additional 1"-wide center mounting bracket.

Recommended mounting creates a 1" gap between back edge of surface and the screen to accommodate cable routing and the attachment or clamp-mounting of other hardware to the surface.

Optional cable management trough is only available when specifying privacy & modesty height option (B). Trough finish is graphite.

Attachment brackets are inset from edge of screen by approximately 8" and require 2<sup>1</sup>/<sub>2</sub>" of work surface for attachment.

Attachment bracket finish is painted graphite.

Screen accepts Customer's Own Material (COM). Yardage is estimated for nondirectional 54"-wide fabrics.

For vertical fabric direction (T):

Height—Yardage

- A—1.51
- B—1.89
- C—1.76
- D—2.14
- E—2.21
- F—2.58

For horizontal fabric direction (R):

Width—Yardage

For heights A/B:

- 24—0.88
- 30—1.07
- 36—1.26
- 42—1.45
- 48—1.64

54—1.83

60—2.02

66—2.21

72—2.39

For heights C/D/E/F:

24—1.76

30—2.14

36—2.52

42—2.90

48—3.28

54—3.65

60—4.03

66—4.41

72—4.79

For information on multiple quantities or directional fabrics, contact COM Department. See Order Information in Appendices.

## Dimensions

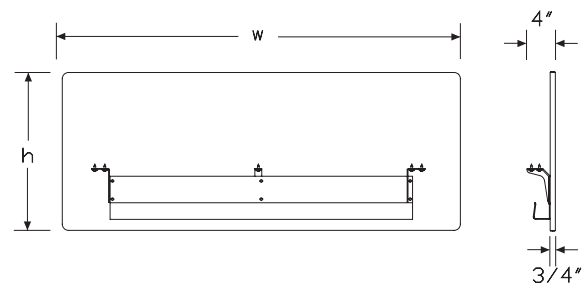

Canvas Vista™ Height Adjustable Table

# Surface-Attached Screen, Flat Edge *continued*

Canvas Vista™ Height Adjustable Table

## Specification Information

### Step 1.

**Y1118.** A

### Step 2. Height

- A** privacy (42" high) A
- B** privacy & modesty (42" high/ 9" below surface) A
- C** privacy (46" high) A
- D** privacy & modesty (46" high/ 9" below surface) A
- E** privacy (53" high) A
- F** privacy & modesty (53" high/ 9" below surface) A

### Step 3. Width

- 24** 24" wide A
- 30** 30" wide A
- 36** 36" wide A
- 42** 42" wide A
- 48** 48" wide A
- 54** 54" wide A
- 60** 60" wide A
- 66** 66" wide A
- 72** 72" wide A

### Step 4. Surface Material

*For 24" wide (24), 30" wide (30), 36" wide (36), 42" wide (42), or 48" wide (48)*

- R** tackable fabric, horizontal A
- T** tackable fabric A

*For 54" wide (54), 60" wide (60), 66" wide (66), or 72" wide (72)*

- R** tackable fabric, horizontal A

### Prices for Steps 1-4.

		R	T
<b>Y1118. A</b>	<b>24</b>	\$311	311
	<b>30</b>	\$336	336
	<b>36</b>	\$401	401
	<b>42</b>	\$432	432
	<b>48</b>	\$463	463
	<b>54</b>	\$491	—
	<b>60</b>	\$533	—
	<b>66</b>	\$558	—
	<b>72</b>	\$595	—

<b>B</b>	<b>24</b>	\$387	387
	<b>30</b>	\$418	418
	<b>36</b>	\$448	448
	<b>42</b>	\$479	479
	<b>48</b>	\$505	505
	<b>54</b>	\$531	—
	<b>60</b>	\$586	—
	<b>66</b>	\$601	—
	<b>72</b>	\$646	—
<b>C</b>	<b>24</b>	\$388	388
	<b>30</b>	\$428	428
	<b>36</b>	\$462	462
	<b>42</b>	\$507	507
	<b>48</b>	\$569	569
	<b>54</b>	\$599	—
	<b>60</b>	\$671	—
	<b>66</b>	\$705	—
	<b>72</b>	\$756	—
<b>D</b>	<b>24</b>	\$489	489
	<b>30</b>	\$546	546
	<b>36</b>	\$609	609
	<b>42</b>	\$623	623
	<b>48</b>	\$648	648
	<b>54</b>	\$666	—
	<b>60</b>	\$737	—
	<b>66</b>	\$799	—
	<b>72</b>	\$831	—
<b>E</b>	<b>24</b>	\$529	529
	<b>30</b>	\$538	538
	<b>36</b>	\$552	552
	<b>42</b>	\$650	650
	<b>48</b>	\$673	673
	<b>54</b>	\$690	—
	<b>60</b>	\$721	—
	<b>66</b>	\$786	—
	<b>72</b>	\$837	—
<b>F</b>	<b>24</b>	\$643	643
	<b>30</b>	\$650	650
	<b>36</b>	\$662	662
	<b>42</b>	\$673	673
	<b>48</b>	\$682	682
	<b>54</b>	\$691	—
	<b>60</b>	\$764	—
	<b>66</b>	\$803	—
	<b>72</b>	\$971	—

## Surface-Attached Screen, Flat Edge *continued*

### Step 5. Cable Trough

*For privacy & modesty (42" high/9" below surface) (B), privacy & modesty (46" high/9" below surface) (D), or privacy & modesty (53" high/9" below surface) (F)*

<b>NC</b>	no cable way <input type="checkbox"/> A	+\$0
<b>CW</b>	cable way <input type="checkbox"/> A	+\$25

### Step 6. Fabric

Price Category C	+\$111
Price Category 1	+\$0
Price Category 2	+\$21
Price Category 3	+\$49
Price Category 4	+\$93
Price Category E	+\$152

*For tackable fabric, horizontal (R)*

Price Category C	+\$111
Price Category 1	+\$0
Price Category 2	+\$21
Price Category 3	+\$49
Price Category 4	+\$93

# Laminate Screen, Surface Attached

Y1120.

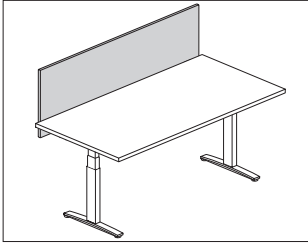

## Product Information

### Description

This screen attaches to an individual height adjustable work surface. It has a laminate surface with frameless design and comes in privacy and modesty sizes. Attachment hardware included.

### Notes

Privacy and modesty panel actual width is 2" less than specified width. Privacy screen (13A) top edge aligns with the 42"-high Canvas datum line; bottom edge is 4" below work surface.

Privacy & modesty screen (13B) top edge aligns with the 42"-high Canvas datum line; bottom edge is 11 1/8" below work surface.

Screens 54" wide and wider include an additional 1"-wide center mounting bracket.

Recommended mounting creates a 1" gap between back edge of surface and the screen to accommodate cable routing and the attachment or clamp-mounting of other hardware to the surface.

Optional cable management trough is only available when specifying privacy & modesty height option (13B). Trough finish is graphite.

Attachment brackets are inset from edge of screen by approximately 8" and require 2 1/2" of work surface for attachment.

Attachment bracket finish is painted graphite.

## Dimensions

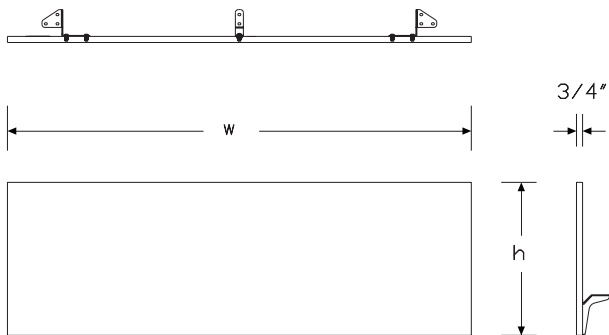

Canvas Vista™ Height Adjustable Table

## Specification Information

### Step 1.

**Y1120.**

### Step 2. Height

**13A** privacy (13 1/2" above worksurface)

**13B** privacy & modesty (13 1/2" above worksurface/11 1/8" below worksurface)

### Step 3. Width

**24** 24" wide

**30** 30" wide

**36** 36" wide

**42** 42" wide

**48** 48" wide

**54** 54" wide

**60** 60" wide

**66** 66" wide

**72** 72" wide

### Step 4. Surface Material

**L** laminate

**U** laminate/universal edge

### Prices for Steps 1-4.

		L	U
<b>Y1120. 13A</b>	<b>24</b>	\$190	190
	<b>30</b>	\$201	201
	<b>36</b>	\$212	212
	<b>42</b>	\$222	222
	<b>48</b>	\$233	233
	<b>54</b>	\$242	242
	<b>60</b>	\$250	250
	<b>66</b>	\$259	259
	<b>72</b>	\$269	269
	<b>13B</b>	<b>24</b>	\$235
<b>30</b>		\$247	247
<b>36</b>		\$260	260
<b>42</b>		\$274	274
<b>48</b>		\$286	286
<b>54</b>		\$298	298
<b>60</b>		\$310	310
<b>66</b>		\$320	320
<b>72</b>		\$330	330

# Laminate Screen, Surface Attached *continued*

## Step 5. Grain Direction

*For 24" wide (24), 30" wide (30), 36" wide (36), 42" wide (42), 48" wide (48), 54" wide (54), or 60" wide (60)*

<b>VTG</b>	vertical grain	+\$0
<b>HRG</b>	horizontal grain	+\$0

*For 66" wide (66) or 72" wide (72)*

<b>HRG</b>	horizontal grain	+\$0
------------	------------------	------

## Step 6. Cable Trough

*For privacy (13<sup>1</sup>/<sub>2</sub>" above worksurface) (13A)*

<b>NC</b>	no cable way	+\$0
-----------	--------------	------

*For privacy & modesty (13<sup>1</sup>/<sub>2</sub>" above worksurface/11<sup>1</sup>/<sub>8</sub>" below worksurface) (13B)*

<b>NC</b>	no cable way	+\$0
<b>CW</b>	cable way	+\$25

## Step 7. Surface Finish

<b>76</b>	light brown walnut	+\$0
<b>8Q</b>	folkstone grey	+\$0
<b>91</b>	white	+\$0
<b>98</b>	studio white	+\$0
<b>CL</b>	cool grey neutral	+\$0
<b>HM</b>	natural maple	+\$0
<b>HP</b>	light anigre	+\$0
<b>HX</b>	aged cherry	+\$0
<b>HY</b>	walnut on cherry	+\$0
<b>LA</b>	light ash	+\$0
<b>LBA</b>	clear on ash	+\$0
<b>LBR</b>	phantom ecru	+\$0
<b>LBS</b>	phantom cocoa	+\$0
<b>LBU</b>	medium matte walnut	+\$0
<b>LBV</b>	warm grey teak	+\$0
<b>LBB</b>	oak on ash	+\$0
<b>LBC</b>	walnut on ash	+\$0
<b>LBD</b>	dark brown walnut	+\$0
<b>LBF</b>	neutral twill	+\$0
<b>LBG</b>	sarum twill	+\$0
<b>LBH</b>	earthen twill	+\$0
<b>LBJ</b>	graphite twill	+\$0
<b>LBK</b>	pewter mesh	+\$0
<b>LBL</b>	steel mesh	+\$0
<b>LBM</b>	crisp linen	+\$0
<b>LBN</b>	classic linen	+\$0
<b>LBP</b>	casual linen	+\$0
<b>LBQ</b>	white twill	+\$0
<b>LU</b>	soft white	+\$0
<b>WL</b>	sandstone	+\$0
<b>WN</b>	warm grey neutral	+\$0

# Laminate Screen, Surface Attached *continued*

## Step 8. Edge Finish

### *For laminate (L)*

<b>76</b>	light brown walnut	+\$0
<b>8Q</b>	folkstone grey	+\$0
<b>91</b>	white	+\$0
<b>98</b>	studio white	+\$0
<b>BU</b>	black umber	+\$0
<b>CL</b>	cool grey neutral	+\$0
<b>HF</b>	inner tone light	+\$0
<b>HM</b>	natural maple	+\$0
<b>HP</b>	light anigre	+\$0
<b>HX</b>	aged cherry	+\$0
<b>HY</b>	walnut on cherry	+\$0
<b>LA</b>	light ash	+\$0
<b>LBA</b>	clear on ash	+\$0
<b>LBR</b>	phantom ecru	+\$0
<b>LBS</b>	phantom cocoa	+\$0
<b>LBU</b>	medium matte walnut	+\$0
<b>LBV</b>	warm grey teak	+\$0
<b>LBB</b>	oak on ash	+\$0
<b>LBC</b>	walnut on ash	+\$0
<b>LBD</b>	dark brown walnut	+\$0
<b>LBF</b>	neutral twill	+\$0
<b>LBG</b>	sarum twill	+\$0
<b>LBH</b>	earthen twill	+\$0
<b>LBJ</b>	graphite twill	+\$0
<b>LBK</b>	pewter mesh	+\$0
<b>LBL</b>	steel mesh	+\$0
<b>LBM</b>	crisp linen	+\$0
<b>LBN</b>	classic linen	+\$0
<b>LBP</b>	casual linen	+\$0
<b>LBQ</b>	white twill	+\$0
<b>LU</b>	soft white	+\$0
<b>MT</b>	medium tone	+\$0
<b>WL</b>	sandstone	+\$0
<b>WN</b>	warm grey neutral	+\$0

### *For laminate/universal edge (U)*

<b>PLY</b>	plywood edge	+\$50
------------	--------------	-------

Credenza with 2" Base, Individual L2CF.  
Box/File

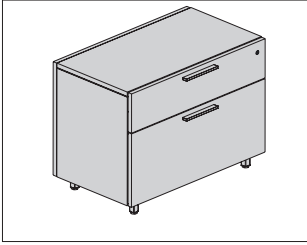

**Product Information**

**Description**

This individual credenza provides drawer storage on 1 side with a box drawer and file drawer. It can be used freestanding or with a structural support bracket to support the chase. Credenza is available with laminate or veneer case and laminate or veneer drawer fronts. It has a recessed 2"-high base, base with fronts to floor, or 2"-high feet with 1" leveling glides. False back panel is optional.

**Notes**

Counterweight is required and is specified with each individual storage unit.

Box and file drawers have full-extension slides. File drawers accommodate side-to-side letter filing. For front-to-back filing of letter- or legal-size hanging files, order optional file converter (L29P.15) separately. Specify 2 file converters per drawer.

Actual credenza depth is 16 1/2"; actual width is 29 7/8"; actual height is 22".

Order optional accessories separately:

- Structural support, low storage to chase (FG292.1B)

Grain direction is vertical on fronts, sides, and back/false back panel.

For keyed-alike locks, order lock plugs separately. See keyed-alike information in appendices.

See planning guide for additional configuration information and dimensions.

**Dimensions**

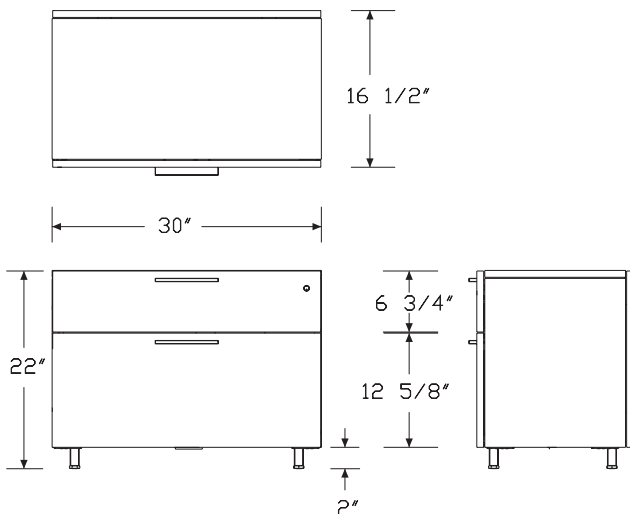

**Specification Information**

**Step 1.**

**L2CF.21**

**Step 2. Width**

**30** 30" wide +\$1770

**Step 3. Depth**

**16** 16.5" deep +\$0

**Step 4. Base/Foot Height**

**1** base +\$22  
**3** base with fronts to floor +\$43  
**5** tube foot +\$106  
**9** c-foot +\$136

**Step 5. Configuration**

**BF** box/file - 30" wide module +\$0

**Step 6. Case Material**

**L** laminate case material +\$0  
**V** veneer case material **A** +\$1671

**Step 7. Front Material**

**L** laminate front material +\$0  
**V** veneer front material **A** +\$335

**Step 8. Pull Type**

**A** arc pull +\$0  
**K** bar pull +\$0  
**U** flush pull +\$0

**Step 9. False Back Panel**

**N** no back panel +\$0  
**B** back panel, matches finish of drawer fronts +\$174

# Credenza with 2" Base, Individual Box/File *continued*

## Step 10. Case Finish

### *For laminate case material (L)*

<b>76</b>	light brown walnut	+\$0
<b>8Q</b>	folkstone grey	+\$0
<b>91</b>	white	+\$0
<b>98</b>	studio white	+\$0
<b>CL</b>	cool grey neutral	+\$0
<b>G1</b>	graphite	+\$0
<b>HM</b>	natural maple	+\$0
<b>HP</b>	light anigre	+\$0
<b>HX</b>	aged cherry	+\$0
<b>HY</b>	walnut on cherry	+\$0
<b>LA</b>	light ash	+\$0
<b>LBA</b>	clear on ash	+\$0
<b>LBB</b>	oak on ash	+\$0
<b>LBC</b>	walnut on ash	+\$0
<b>LBD</b>	dark brown walnut	+\$0
<b>LBF</b>	neutral twill	+\$0
<b>LBG</b>	sarum twill	+\$0
<b>LBH</b>	earthen twill	+\$0
<b>LBJ</b>	graphite twill	+\$0
<b>LBK</b>	pewter mesh	+\$0
<b>LBL</b>	steel mesh	+\$0
<b>LBM</b>	crisp linen	+\$0
<b>LBN</b>	classic linen	+\$0
<b>LBP</b>	casual linen	+\$0
<b>LBQ</b>	white twill	+\$0
<b>LBR</b>	phantom ecru	+\$0
<b>LBS</b>	phantom cocoa	+\$0
<b>LBU</b>	medium matte walnut	+\$0
<b>LBV</b>	warm grey teak	+\$0
<b>LU</b>	soft white	+\$0
<b>WL</b>	sandstone	+\$0
<b>WN</b>	warm grey neutral	+\$0

### *For veneer case material (V)*

<b>2U</b>	light brown walnut	+\$0
<b>40</b>	dark brown walnut	+\$0
<b>ED</b>	aged cherry	+\$0
<b>EK</b>	medium red walnut	+\$0
<b>EW</b>	medium matte walnut	+\$0
<b>ET</b>	clear on ash	+\$0
<b>EU</b>	oak on ash	+\$0
<b>EV</b>	walnut on ash	+\$0
<b>UL</b>	natural maple	+\$0
<b>UX</b>	walnut on cherry	+\$0

## Step 11. Front Finish

### *For laminate front material (L)*

<b>76</b>	light brown walnut	+\$0
<b>8Q</b>	folkstone grey	+\$0
<b>91</b>	white	+\$0
<b>98</b>	studio white	+\$0
<b>CL</b>	cool grey neutral	+\$0
<b>G1</b>	graphite	+\$0
<b>HM</b>	natural maple	+\$0
<b>HP</b>	light anigre	+\$0
<b>HX</b>	aged cherry	+\$0
<b>HY</b>	walnut on cherry	+\$0
<b>LA</b>	light ash	+\$0
<b>LBA</b>	clear on ash	+\$0
<b>LBB</b>	oak on ash	+\$0
<b>LBC</b>	walnut on ash	+\$0
<b>LBD</b>	dark brown walnut	+\$0
<b>LBF</b>	neutral twill	+\$0
<b>LBG</b>	sarum twill	+\$0
<b>LBH</b>	earthen twill	+\$0
<b>LBJ</b>	graphite twill	+\$0
<b>LBK</b>	pewter mesh	+\$0
<b>LBL</b>	steel mesh	+\$0
<b>LBM</b>	crisp linen	+\$0
<b>LBN</b>	classic linen	+\$0
<b>LBP</b>	casual linen	+\$0
<b>LBQ</b>	white twill	+\$0
<b>LBR</b>	phantom ecru	+\$0
<b>LBS</b>	phantom cocoa	+\$0
<b>LBU</b>	medium matte walnut	+\$0
<b>LBV</b>	warm grey teak	+\$0
<b>LU</b>	soft white	+\$0
<b>WL</b>	sandstone	+\$0
<b>WN</b>	warm grey neutral	+\$0

### *For veneer front material (V)*

<b>2U</b>	light brown walnut	+\$0
<b>40</b>	dark brown walnut	+\$0
<b>ED</b>	aged cherry	+\$0
<b>EK</b>	medium red walnut	+\$0
<b>EW</b>	medium matte walnut	+\$0
<b>ET</b>	clear on ash	+\$0
<b>EU</b>	oak on ash	+\$0
<b>EV</b>	walnut on ash	+\$0
<b>UL</b>	natural maple	+\$0
<b>UX</b>	walnut on cherry	+\$0

# Credenza with 2" Base, Individual Box/File *continued*

## Step 12. Pull Finish

### *For arc pull (A)*

<b>NH</b>	brushed nickel	+\$0
<b>NK</b>	black nickel	+\$0

### Smooth Paint

### *For bar pull (K) or flush pull (U)*

<b>8Q</b>	folkstone grey	+\$0
<b>91</b>	white	+\$0
<b>98</b>	studio white	+\$0
<b>G1</b>	graphite	+\$0
<b>WL</b>	sandstone	+\$0

### Metallic Paint

### *For bar pull (K) or flush pull (U)*

<b>CN</b>	metallic champagne	+\$0
<b>MS</b>	metallic silver	+\$0

### Sand Texture Paint

### *For bar pull (K) or flush pull (U)*

<b>79</b>	green apple	+\$16
<b>BK</b>	black	+\$16
<b>MY3</b>	yellow oxide	+\$16
<b>RO</b>	red	+\$16
<b>TRQ</b>	turquoise	+\$16

## Step 13. Foot Finish

### *For tube foot (5) or c-foot (9)*

### Smooth Paint

<b>8Q</b>	folkstone grey	+\$0
<b>91</b>	white	+\$0
<b>98</b>	studio white	+\$0
<b>CL</b>	cool grey neutral	+\$0
<b>WL</b>	sandstone	+\$0
<b>WN</b>	warm grey neutral	+\$0

### Metallic Paint

<b>CN</b>	metallic champagne	+\$0
<b>EH</b>	metallic bronze	+\$0
<b>MS</b>	metallic silver	+\$0

### Sand Texture Paint

<b>BK</b>	black	+\$0
<b>G1</b>	graphite	+\$0

## Step 14. Counterweight

<b>CB</b>	counterweight	+\$0
-----------	---------------	------

## Step 15. Lock Option

<b>KA</b>	keyed alike	+\$0
<b>KC</b>	keyed differently, chrome	+\$0
<b>KD</b>	keyed differently, black	+\$0

Credenza with 2" Base, Individual L2CF.  
Box/File + Door

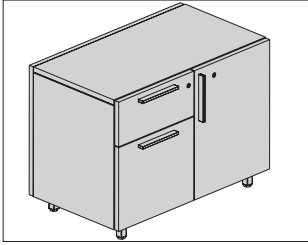

**Product Information**

**Description**

This individual credenza provides 6 configurations of 15", 18"- and 30"-wide box drawer, file drawer, and cabinet modules on 1 side of the unit. It can be used freestanding or with a structural support bracket to support the chase. Credenza is available with laminate or veneer case and laminate or veneer fronts. It has a recessed 2"-high base, base with fronts to floor, or 2"-high feet with 1" leveling glides. False back panel is optional.

**Notes**

Counterweight is required and is specified with each individual storage unit.

Box and file drawers have full-extension slides. File drawers 15" wide accommodate front-to-back filing. File drawers 30" wide accommodate side-to-side letter filing. For front-to-back filing of letter- or legal-size hanging files, order optional file converter (L29P.15) separately. Specify 2 file converters per drawer.

Actual credenza depth is 16 1/2"; actual height is 22".

Actual credenza widths are:

Nominal—Actual

30"—29 5/8"

45"—44 3/4"

48"—47 3/4"

Order optional accessories separately:

- Structural support, low storage to chase (FG292.1B)

Grain direction is vertical on fronts, sides, and back/false back panel.

For keyed-alike locks, order lock plugs separately. See keyed-alike information in appendices.

See planning guide for additional configuration information and dimensions.

**Dimensions**

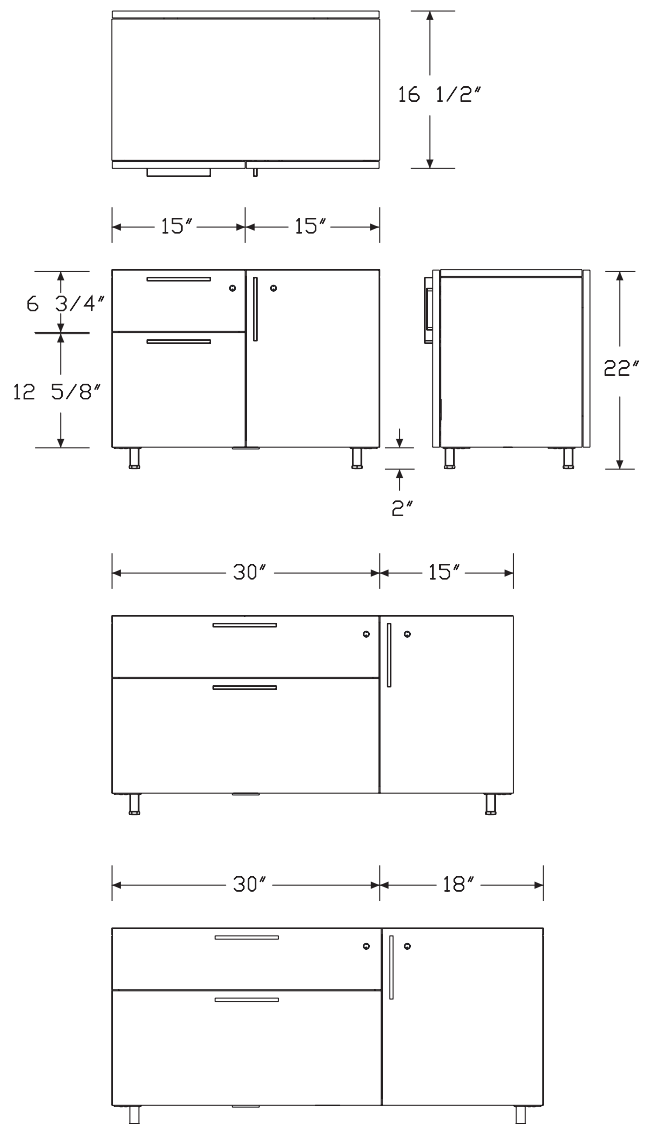

# Credenza with 2" Base, Individual Box/File + Door *continued*

Specification Information		
Step 1.		
<b>L2CF.22</b>		
Step 2. Width		
<b>30</b>	30" wide	+\$1880
<b>45</b>	45" wide	+\$2214
<b>48</b>	48" wide	+\$2240
Step 3. Depth		
<b>16</b>	16.5" deep	+\$0
Step 4. Base/Foot Height		
<b>1</b>	base	+\$22
<b>3</b>	base with fronts to floor	+\$43
<b>5</b>	tube foot	+\$106
<b>9</b>	c-foot	+\$136
Step 5. Configuration		
<i>For 30" wide (30)</i>		
<b>B1</b>	box/file, door - 15" wide modules	+\$0
<b>D1</b>	door, box/file - 15" wide modules	+\$0
<i>For 45" wide (45)</i>		
<b>B2</b>	box/file - 30" wide module, door - 15" wide module	+\$0
<b>D2</b>	door - 15" wide module, box/file - 30" wide module	+\$0
<i>For 48" wide (48)</i>		
<b>B3</b>	box/file - 30" wide module, door - 18" wide module	+\$0
<b>D3</b>	door - 18" wide module, box/file - 30" wide module	+\$0
Step 6. Case Material		
<b>L</b>	laminate case material	+\$0
<b>V</b>	veneer case material <input type="checkbox"/> A	+\$2323
Step 7. Front Material		
<b>L</b>	laminate front material	+\$0
<b>V</b>	veneer front material <input type="checkbox"/> A	+\$439
Step 8. Pull Type		
<b>A</b>	arc pull	+\$0
<b>K</b>	bar pull	+\$0
<b>U</b>	flush pull	+\$0

Step 9. False Back Panel		
<b>N</b>	no back panel	+\$0
<b>B</b>	back panel, matches finish of the front panels and drawer fronts	+\$174
Step 10. Case Finish		
<i>For laminate case material (L)</i>		
<b>76</b>	light brown walnut	+\$0
<b>8Q</b>	folkstone grey	+\$0
<b>91</b>	white	+\$0
<b>98</b>	studio white	+\$0
<b>CL</b>	cool grey neutral	+\$0
<b>G1</b>	graphite	+\$0
<b>HM</b>	natural maple	+\$0
<b>HP</b>	light anigre	+\$0
<b>HX</b>	aged cherry	+\$0
<b>HY</b>	walnut on cherry	+\$0
<b>LA</b>	light ash	+\$0
<b>LBA</b>	clear on ash	+\$0
<b>LBB</b>	oak on ash	+\$0
<b>LBC</b>	walnut on ash	+\$0
<b>LBD</b>	dark brown walnut	+\$0
<b>LBF</b>	neutral twill	+\$0
<b>LBG</b>	sarum twill	+\$0
<b>LBH</b>	earthen twill	+\$0
<b>LBJ</b>	graphite twill	+\$0
<b>LBK</b>	pewter mesh	+\$0
<b>LBL</b>	steel mesh	+\$0
<b>LBM</b>	crisp linen	+\$0
<b>LBN</b>	classic linen	+\$0
<b>LBP</b>	casual linen	+\$0
<b>LBQ</b>	white twill	+\$0
<b>LBR</b>	phantom ecru	+\$0
<b>LBS</b>	phantom cocoa	+\$0
<b>LBU</b>	medium matte walnut	+\$0
<b>LBV</b>	warm grey teak	+\$0
<b>LU</b>	soft white	+\$0
<b>WL</b>	sandstone	+\$0
<b>WN</b>	warm grey neutral	+\$0

# Credenza with 2" Base, Individual Box/File + Door *continued*

## For veneer case material (V)

<b>2U</b>	light brown walnut	+\$0
<b>40</b>	dark brown walnut	+\$0
<b>ED</b>	aged cherry	+\$0
<b>EK</b>	medium red walnut	+\$0
<b>ET</b>	clear on ash	+\$0
<b>EU</b>	oak on ash	+\$0
<b>EV</b>	walnut on ash	+\$0
<b>EW</b>	medium matte walnut	+\$0
<b>UL</b>	natural maple	+\$0
<b>UX</b>	walnut on cherry	+\$0

## Step 11. Front Finish

### For laminate front material (L)

<b>76</b>	light brown walnut	+\$0
<b>8Q</b>	folkstone grey	+\$0
<b>91</b>	white	+\$0
<b>98</b>	studio white	+\$0
<b>CL</b>	cool grey neutral	+\$0
<b>G1</b>	graphite	+\$0
<b>HM</b>	natural maple	+\$0
<b>HP</b>	light anigre	+\$0
<b>HX</b>	aged cherry	+\$0
<b>HY</b>	walnut on cherry	+\$0
<b>LA</b>	light ash	+\$0
<b>LBA</b>	clear on ash	+\$0
<b>LBB</b>	oak on ash	+\$0
<b>LBC</b>	walnut on ash	+\$0
<b>LBD</b>	dark brown walnut	+\$0
<b>LBF</b>	neutral twill	+\$0
<b>LBG</b>	sarum twill	+\$0
<b>LBH</b>	earthen twill	+\$0
<b>LBJ</b>	graphite twill	+\$0
<b>LBK</b>	pewter mesh	+\$0
<b>LBL</b>	steel mesh	+\$0
<b>LBM</b>	crisp linen	+\$0
<b>LBN</b>	classic linen	+\$0
<b>LBP</b>	casual linen	+\$0
<b>LBQ</b>	white twill	+\$0
<b>LBR</b>	phantom ecru	+\$0
<b>LBS</b>	phantom cocoa	+\$0
<b>LBU</b>	medium matte walnut	+\$0
<b>LBV</b>	warm grey teak	+\$0
<b>LU</b>	soft white	+\$0
<b>WL</b>	sandstone	+\$0
<b>WN</b>	warm grey neutral	+\$0

## For veneer front material (V)

<b>2U</b>	light brown walnut	+\$0
<b>40</b>	dark brown walnut	+\$0
<b>ED</b>	aged cherry	+\$0
<b>EK</b>	medium red walnut	+\$0
<b>ET</b>	clear on ash	+\$0
<b>EU</b>	oak on ash	+\$0
<b>EV</b>	walnut on ash	+\$0
<b>EW</b>	medium matte walnut	+\$0
<b>UL</b>	natural maple	+\$0
<b>UX</b>	walnut on cherry	+\$0

## Step 12. Pull Finish

### For arc pull (A)

<b>NH</b>	brushed nickel	+\$0
<b>NK</b>	black nickel	+\$0

### Smooth Paint

#### For bar pull (K) or flush pull (U)

<b>8Q</b>	folkstone grey	+\$0
<b>91</b>	white	+\$0
<b>98</b>	studio white	+\$0
<b>G1</b>	graphite	+\$0
<b>WL</b>	sandstone	+\$0

### Metallic Paint

#### For bar pull (K) or flush pull (U)

<b>CN</b>	metallic champagne	+\$0
<b>MS</b>	metallic silver	+\$0

### Sand Texture Paint

#### For bar pull (K) or flush pull (U)

<b>79</b>	green apple	+\$16
<b>BK</b>	black	+\$16
<b>MY3</b>	yellow oxide	+\$16
<b>RO</b>	red	+\$16
<b>TRQ</b>	turquoise	+\$16

## Credenza with 2" Base, Individual Box/File + Door *continued*

### Step 13. Foot Finish *For tube foot (5) or c-foot (9)*

#### Smooth Paint

<b>8Q</b>	folkstone grey	+\$0
<b>91</b>	white	+\$0
<b>98</b>	studio white	+\$0
<b>CL</b>	cool grey neutral	+\$0
<b>WL</b>	sandstone	+\$0
<b>WN</b>	warm grey neutral	+\$0

#### Metallic Paint

<b>CN</b>	metallic champagne	+\$0
<b>EH</b>	metallic bronze	+\$0
<b>MS</b>	metallic silver	+\$0

#### Sand Texture Paint

<b>BK</b>	black	+\$0
<b>G1</b>	graphite	+\$0

### Step 14. Counterweight

<b>CB</b>	counterweight	+\$0
-----------	---------------	------

### Step 15. Lock Option

<b>KA</b>	keyed alike	+\$0
<b>KC</b>	keyed differently, chrome	+\$0
<b>KD</b>	keyed differently, black	+\$0

Credenza with 8" Base, Individual 1 Module L2CF.

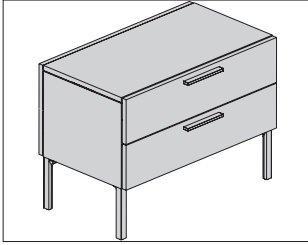

**Product Information**

**Description**  
 This individual credenza provides drawer storage on 1 side with 2 box drawers and can be used freestanding or with a structural support bracket to support the chase. Options include a lock or no lock and a false back panel. Credenza is available with laminate or veneer case and laminate or veneer drawer fronts and has 8"-high feet with 1 1/2" leveling glides.

**Notes**

Counterweight is required and is specified with each individual storage unit.  
 Box drawers have full-extension slides.  
 Actual credenza depth is 16 1/2"; actual width is 29 7/8"; actual height is 22".  
 Order optional accessories separately:  
 • Structural support, low storage to chase (FG292.1B)  
 Grain direction is vertical on fronts, sides, and back/false back panel.  
 For keyed-alike locks, order lock plugs separately. See keyed-alike information in appendices.  
 See planning guide for additional configuration information and dimensions.

**Dimensions**

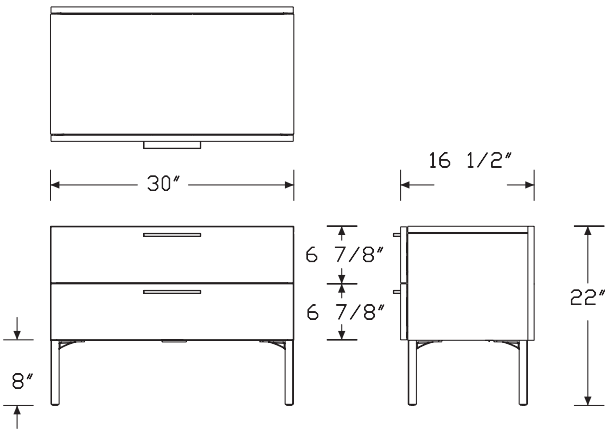

Canvas Vista™ Storage - Tu® Wood for Canvas Vista™

**Specification Information**

**Step 1.**

**L2CF.81**

**Step 2. Width**  
**30** 30" wide +\$1916

**Step 3. Depth**  
**16** 16.5" deep +\$0

**Step 4. Base/Foot Height**  
**8** 8" foot +\$0

**Step 5. Configuration**  
**BB** box/box - 30" wide module +\$0

**Step 6. Case Material**  
**L** laminate case material +\$0  
**V** veneer case material [A] +\$1984

**Step 7. Front Material**  
**L** laminate front material +\$0  
**V** veneer front material [A] +\$366

**Step 8. Pull Type**  
**A** arc pull +\$0  
**K** bar pull +\$0  
**U** flush pull +\$0

**Step 9. False Back Panel**  
**N** no back panel +\$0  
**B** back panel, matches finish of drawer fronts +\$174

**Step 10. Lock**  
**L** lock +\$0  
**N** no lock -\$24

# Credenza with 8" Base, Individual 1 Module *continued*

## Step 11. Case Finish

### *For laminate case material (L)*

<b>76</b>	light brown walnut	+\$0
<b>8Q</b>	folkstone grey	+\$0
<b>91</b>	white	+\$0
<b>98</b>	studio white	+\$0
<b>CL</b>	cool grey neutral	+\$0
<b>G1</b>	graphite	+\$0
<b>HM</b>	natural maple	+\$0
<b>HP</b>	light anigre	+\$0
<b>HX</b>	aged cherry	+\$0
<b>HY</b>	walnut on cherry	+\$0
<b>LA</b>	light ash	+\$0
<b>LBA</b>	clear on ash	+\$0
<b>LBB</b>	oak on ash	+\$0
<b>LBC</b>	walnut on ash	+\$0
<b>LBD</b>	dark brown walnut	+\$0
<b>LBF</b>	neutral twill	+\$0
<b>LBG</b>	sarum twill	+\$0
<b>LBH</b>	earthen twill	+\$0
<b>LBJ</b>	graphite twill	+\$0
<b>LBK</b>	pewter mesh	+\$0
<b>LBL</b>	steel mesh	+\$0
<b>LBM</b>	crisp linen	+\$0
<b>LBN</b>	classic linen	+\$0
<b>LBP</b>	casual linen	+\$0
<b>LBQ</b>	white twill	+\$0
<b>LBR</b>	phantom ecru	+\$0
<b>LBS</b>	phantom cocoa	+\$0
<b>LBU</b>	medium matte walnut	+\$0
<b>LBV</b>	warm grey teak	+\$0
<b>LU</b>	soft white	+\$0
<b>WL</b>	sandstone	+\$0
<b>WN</b>	warm grey neutral	+\$0

### *For veneer case material (V)*

<b>2U</b>	light brown walnut	+\$0
<b>40</b>	dark brown walnut	+\$0
<b>ED</b>	aged cherry	+\$0
<b>EK</b>	medium red walnut	+\$0
<b>ET</b>	clear on ash	+\$0
<b>EU</b>	oak on ash	+\$0
<b>EV</b>	walnut on ash	+\$0
<b>EW</b>	medium matte walnut	+\$0
<b>UL</b>	natural maple	+\$0
<b>UX</b>	walnut on cherry	+\$0

## Step 12. Front Finish

### *For laminate front material (L)*

<b>76</b>	light brown walnut	+\$0
<b>8Q</b>	folkstone grey	+\$0
<b>91</b>	white	+\$0
<b>98</b>	studio white	+\$0
<b>CL</b>	cool grey neutral	+\$0
<b>G1</b>	graphite	+\$0
<b>HM</b>	natural maple	+\$0
<b>HP</b>	light anigre	+\$0
<b>HX</b>	aged cherry	+\$0
<b>HY</b>	walnut on cherry	+\$0
<b>LA</b>	light ash	+\$0
<b>LBA</b>	clear on ash	+\$0
<b>LBB</b>	oak on ash	+\$0
<b>LBC</b>	walnut on ash	+\$0
<b>LBD</b>	dark brown walnut	+\$0
<b>LBF</b>	neutral twill	+\$0
<b>LBG</b>	sarum twill	+\$0
<b>LBH</b>	earthen twill	+\$0
<b>LBJ</b>	graphite twill	+\$0
<b>LBK</b>	pewter mesh	+\$0
<b>LBL</b>	steel mesh	+\$0
<b>LBM</b>	crisp linen	+\$0
<b>LBN</b>	classic linen	+\$0
<b>LBP</b>	casual linen	+\$0
<b>LBQ</b>	white twill	+\$0
<b>LBR</b>	phantom ecru	+\$0
<b>LBS</b>	phantom cocoa	+\$0
<b>LBU</b>	medium matte walnut	+\$0
<b>LBV</b>	warm grey teak	+\$0
<b>LU</b>	soft white	+\$0
<b>WL</b>	sandstone	+\$0
<b>WN</b>	warm grey neutral	+\$0

### *For veneer front material (V)*

<b>2U</b>	light brown walnut	+\$0
<b>40</b>	dark brown walnut	+\$0
<b>ED</b>	aged cherry	+\$0
<b>EK</b>	medium red walnut	+\$0
<b>ET</b>	clear on ash	+\$0
<b>EU</b>	oak on ash	+\$0
<b>EV</b>	walnut on ash	+\$0
<b>EW</b>	medium matte walnut	+\$0
<b>UL</b>	natural maple	+\$0
<b>UX</b>	walnut on cherry	+\$0

# Credenza with 8" Base, Individual 1 Module *continued*

## Step 13. Pull Finish

### *For arc pull (A)*

<b>NH</b>	brushed nickel <span style="border: 1px solid black; padding: 0 2px;">A</span>	+\$0
<b>NK</b>	black nickel <span style="border: 1px solid black; padding: 0 2px;">A</span>	+\$0

### Smooth Paint

#### *For bar pull (K) or flush pull (U)*

<b>8Q</b>	folkstone grey	+\$0
<b>91</b>	white	+\$0
<b>98</b>	studio white	+\$0
<b>G1</b>	graphite	+\$0
<b>WL</b>	sandstone	+\$0

### Metallic Paint

#### *For bar pull (K) or flush pull (U)*

<b>CN</b>	metallic champagne	+\$0
<b>MS</b>	metallic silver	+\$0

### Sand Texture Paint

#### *For bar pull (K) or flush pull (U)*

<b>79</b>	green apple	+\$16
<b>BK</b>	black	+\$16
<b>MY3</b>	yellow oxide	+\$16
<b>RO</b>	red	+\$16
<b>TRQ</b>	turquoise	+\$16

## Step 14. Foot Finish

### Smooth Paint

<b>8Q</b>	folkstone grey	+\$0
<b>91</b>	white	+\$0
<b>98</b>	studio white	+\$0
<b>CL</b>	cool grey neutral	+\$0
<b>WL</b>	sandstone	+\$0
<b>WN</b>	warm grey neutral	+\$0

### Metallic Paint

<b>CN</b>	metallic champagne	+\$0
<b>EH</b>	metallic bronze	+\$0
<b>MS</b>	metallic silver	+\$0

### Sand Texture Paint

<b>BK</b>	black	+\$0
<b>G1</b>	graphite	+\$0

## Step 15. Counterweight

<b>CB</b>	counterweight	+\$0
-----------	---------------	------

## Step 16. Lock Option

### *For lock (L)*

<b>KA</b>	keyed alike	+\$0
<b>KC</b>	keyed differently, chrome	+\$0
<b>KD</b>	keyed differently, black	+\$0

Credenza with 8" Base, Individual L2CF.  
2 Module - 30" Wide

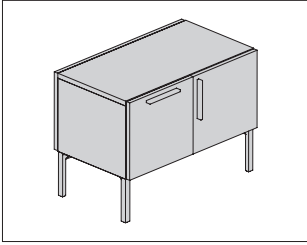

**Product Information**

**Description**

This individual credenza provides 4 configurations of 15"-wide file drawer and cabinet modules on 1 side of the unit. It can be used freestanding or with a structural support bracket to support the chase. Options include a lock or no lock and a false back panel. Credenza is available with laminate or veneer case and laminate or veneer fronts and has 8"-high feet with 1 1/2" leveling glides.

**Notes**

Counterweight is required and is specified with each individual storage unit.

File drawers have full-extension slides and accommodate front-to-back filing.

Actual credenza depth is 16 1/2"; actual width is 29 5/8"; actual height is 22".

Order optional accessories separately:

- Structural support, low storage to chase (FG292.1B)

Grain direction is vertical on fronts, sides, and back/false back panel.

For keyed-alike locks, order lock plugs separately. See keyed-alike information in appendices.

See planning guide for additional configuration information and dimensions.

**Dimensions**

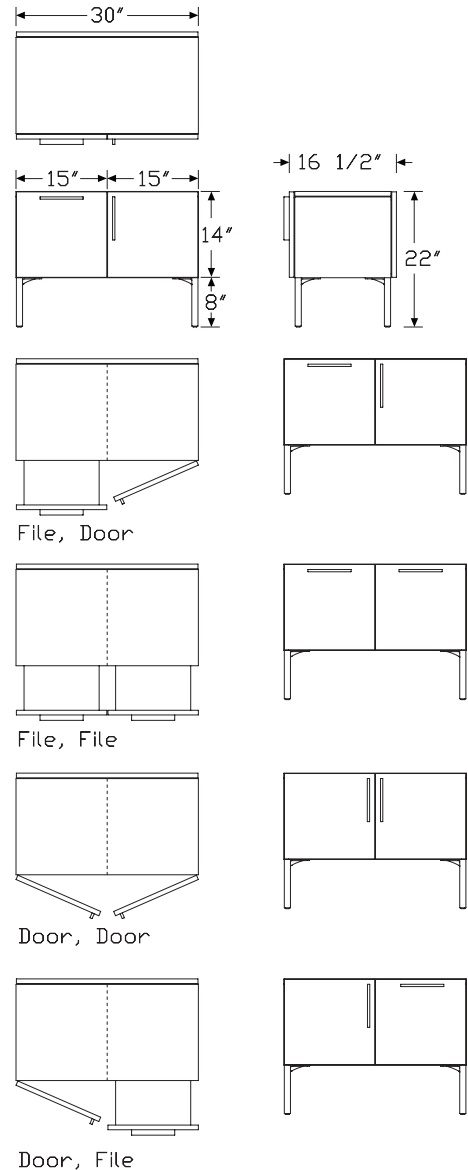

# Credenza with 8" Base, Individual 2 Module - 30" Wide *continued*

Canvas Vista™ Storage - Tu® Wood for Canvas Vista™

Specification Information		
Step 1.		
<b>L2CF.82</b>		
Step 2. Width		
<b>30</b>	30" wide	+\$1676
Step 3. Depth		
<b>16</b>	16.5" deep	+\$0
Step 4. Base/Foot Height		
<b>8</b>	8" foot	+\$0
Step 5. Configuration		
<b>FF</b>	file, file - 15" wide modules	+\$230
<b>DD</b>	door, door - 15" wide modules	+\$0
<b>FD</b>	file, door - 15" wide modules	+\$111
<b>DF</b>	door, file - 15" wide modules	+\$111
Step 6. Case Material		
<b>L</b>	laminate case material	+\$0
<b>V</b>	veneer case material <b>A</b>	+\$1984
Step 7. Front Material		
<b>L</b>	laminate front material	+\$0
<b>V</b>	veneer front material <b>A</b>	+\$366
Step 8. Pull Type		
<b>A</b>	arc pull	+\$0
<b>K</b>	bar pull	+\$0
<b>U</b>	flush pull	+\$0
Step 9. False Back Panel		
<b>N</b>	no back panel	+\$0
<b>B</b>	back panel, matches finish of the front panels and drawer fronts	+\$174
Step 10. Lock		
<b>L</b>	lock	+\$0
<b>N</b>	no lock	-\$48

Step 11. Case Finish		
<i>For laminate case material (L)</i>		
<b>76</b>	light brown walnut	+\$0
<b>8Q</b>	folkstone grey	+\$0
<b>91</b>	white	+\$0
<b>98</b>	studio white	+\$0
<b>CL</b>	cool grey neutral	+\$0
<b>G1</b>	graphite	+\$0
<b>HM</b>	natural maple	+\$0
<b>HP</b>	light anigre	+\$0
<b>HX</b>	aged cherry	+\$0
<b>HY</b>	walnut on cherry	+\$0
<b>LA</b>	light ash	+\$0
<b>LBA</b>	clear on ash	+\$0
<b>LBB</b>	oak on ash	+\$0
<b>LBC</b>	walnut on ash	+\$0
<b>LBD</b>	dark brown walnut	+\$0
<b>LBF</b>	neutral twill	+\$0
<b>LBG</b>	sarum twill	+\$0
<b>LBH</b>	earthen twill	+\$0
<b>LBJ</b>	graphite twill	+\$0
<b>LBK</b>	pewter mesh	+\$0
<b>LBL</b>	steel mesh	+\$0
<b>LBM</b>	crisp linen	+\$0
<b>LBN</b>	classic linen	+\$0
<b>LBP</b>	casual linen	+\$0
<b>LBQ</b>	white twill	+\$0
<b>LBR</b>	phantom ecru	+\$0
<b>LBS</b>	phantom cocoa	+\$0
<b>LBU</b>	medium matte walnut	+\$0
<b>LBV</b>	warm grey teak	+\$0
<b>LU</b>	soft white	+\$0
<b>WL</b>	sandstone	+\$0
<b>WN</b>	warm grey neutral	+\$0
<i>For veneer case material (V)</i>		
<b>2U</b>	light brown walnut	+\$0
<b>40</b>	dark brown walnut	+\$0
<b>ED</b>	aged cherry	+\$0
<b>EK</b>	medium red walnut	+\$0
<b>ET</b>	clear on ash	+\$0
<b>EU</b>	oak on ash	+\$0
<b>EV</b>	walnut on ash	+\$0
<b>EW</b>	medium matte walnut	+\$0
<b>UL</b>	natural maple	+\$0
<b>UX</b>	walnut on cherry	+\$0

Credenza with 8" Base, Individual  
2 Module - 30" Wide *continued*

Step 12. Front Finish

*For laminate front material (L)*

<b>76</b>	light brown walnut	+\$0
<b>8Q</b>	folkstone grey	+\$0
<b>91</b>	white	+\$0
<b>98</b>	studio white	+\$0
<b>CL</b>	cool grey neutral	+\$0
<b>G1</b>	graphite	+\$0
<b>HM</b>	natural maple	+\$0
<b>HP</b>	light anigre	+\$0
<b>HX</b>	aged cherry	+\$0
<b>HY</b>	walnut on cherry	+\$0
<b>LA</b>	light ash	+\$0
<b>LBA</b>	clear on ash	+\$0
<b>LBB</b>	oak on ash	+\$0
<b>LBC</b>	walnut on ash	+\$0
<b>LBD</b>	dark brown walnut	+\$0
<b>LBF</b>	neutral twill	+\$0
<b>LBG</b>	sarum twill	+\$0
<b>LBH</b>	earthen twill	+\$0
<b>LBJ</b>	graphite twill	+\$0
<b>LBK</b>	pewter mesh	+\$0
<b>LBL</b>	steel mesh	+\$0
<b>LBM</b>	crisp linen	+\$0
<b>LBN</b>	classic linen	+\$0
<b>LBP</b>	casual linen	+\$0
<b>LBQ</b>	white twill	+\$0
<b>LBR</b>	phantom ecru	+\$0
<b>LBS</b>	phantom cocoa	+\$0
<b>LBU</b>	medium matte walnut	+\$0
<b>LBV</b>	warm grey teak	+\$0
<b>LU</b>	soft white	+\$0
<b>WL</b>	sandstone	+\$0
<b>WN</b>	warm grey neutral	+\$0

*For veneer front material (V)*

<b>2U</b>	light brown walnut	+\$0
<b>40</b>	dark brown walnut	+\$0
<b>ED</b>	aged cherry	+\$0
<b>EK</b>	medium red walnut	+\$0
<b>ET</b>	clear on ash	+\$0
<b>EU</b>	oak on ash	+\$0
<b>EV</b>	walnut on ash	+\$0
<b>EW</b>	medium matte walnut	+\$0
<b>UL</b>	natural maple	+\$0
<b>UX</b>	walnut on cherry	+\$0

Step 13. Pull Finish

*For arc pull (A)*

<b>NH</b>	brushed nickel	+\$0
<b>NK</b>	black nickel	+\$0

Smooth Paint

*For bar pull (K) or flush pull (U)*

<b>8Q</b>	folkstone grey	+\$0
<b>91</b>	white	+\$0
<b>98</b>	studio white	+\$0
<b>G1</b>	graphite	+\$0
<b>WL</b>	sandstone	+\$0

Metallic Paint

*For bar pull (K) or flush pull (U)*

<b>CN</b>	metallic champagne	+\$0
<b>MS</b>	metallic silver	+\$0

Sand Texture Paint

*For bar pull (K) or flush pull (U)*

<b>79</b>	green apple	+\$16
<b>BK</b>	black	+\$16
<b>MY3</b>	yellow oxide	+\$16
<b>RO</b>	red	+\$16
<b>TRQ</b>	turquoise	+\$16

Step 14. Foot Finish

Smooth Paint

<b>8Q</b>	folkstone grey	+\$0
<b>91</b>	white	+\$0
<b>98</b>	studio white	+\$0
<b>CL</b>	cool grey neutral	+\$0
<b>WL</b>	sandstone	+\$0
<b>WN</b>	warm grey neutral	+\$0

Metallic Paint

<b>CN</b>	metallic champagne	+\$0
<b>EH</b>	metallic bronze	+\$0
<b>MS</b>	metallic silver	+\$0

Sand Texture Paint

<b>BK</b>	black	+\$0
<b>G1</b>	graphite	+\$0

Credenza with 8" Base, Individual  
 2 Module - 30" Wide *continued*

---

Step 15. Counterweight  
 For file, file - 15" wide modules (FF), file, door - 15" wide modules (FD),  
 or door, file - 15" wide modules (DF)

<b>CB</b>	counterweight	+\$0
-----------	---------------	------

---

Step 16. Lock Option  
 For lock (L)

<b>KA</b>	keyed alike	+\$0
<b>KC</b>	keyed differently, chrome	+\$0
<b>KD</b>	keyed differently, black	+\$0

Credenza with 8" Base, Individual L2CF.  
2 Module - 45" Wide

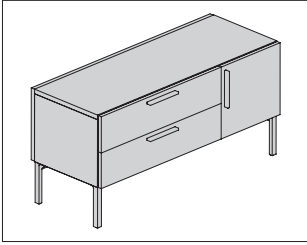

**Product Information**

**Description**

This individual credenza provides 6 configurations of 15"- and 30"-wide box drawer, file drawer, cabinet, and tip-out bin modules on 1 side of the unit. It can be used freestanding or with a structural support bracket to support the chase. Options include a lock or no lock and a false back panel. Credenza is available with laminate or veneer case and laminate or veneer fronts and has 8"-high feet with 1/2" leveling glides.

**Notes**

Counterweight is required and is specified with each individual storage unit.

Box and file drawers have full-extension slides. File drawers accommodate front-to-back filing.

Actual credenza depth is 16 1/2"; actual width is 44 3/4"; actual height is 22".

Order optional accessories separately:

- Structural support, low storage to chase (FG292.1B)

Grain direction is vertical on fronts, sides, and back/false back panel.

For keyed-alike locks, order lock plugs separately. See keyed-alike information in appendices.

Dimensional illustration does not include all possible configurations.

See planning guide for additional configuration information and dimensions.

**Dimensions**

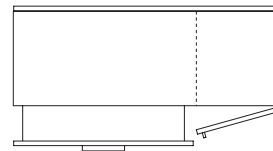
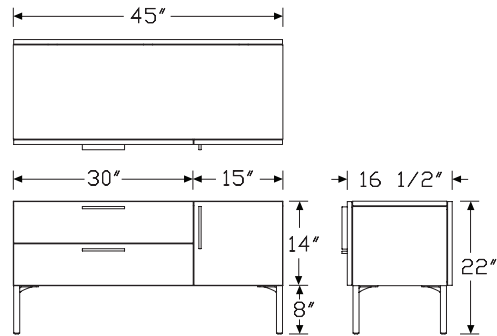

Box/Box, Door

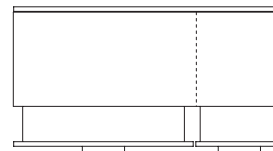
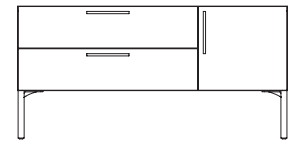

Box/Box, File

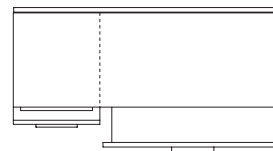
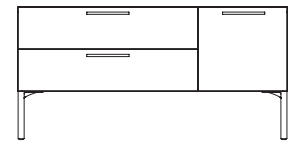

Tip-Out Bin, Box/Box

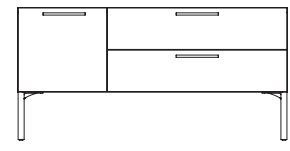

# Credenza with 8" Base, Individual 2 Module - 45" Wide *continued*

Canvas Vista™ Storage - Tu® Wood for Canvas Vista™

Specification Information		
Step 1.		
<b>L2CF.82</b>		
Step 2. Width		
<b>45</b>	45" wide	+\$2287
Step 3. Depth		
<b>16</b>	16.5" deep	+\$0
Step 4. Base/Foot Height		
<b>8</b>	8" foot	+\$0
Step 5. Configuration		
<b>2BB</b>	tip-out bin - 15" wide module, box/box - 30" wide module	+\$131
<b>BB2</b>	box/box - 30" wide module, tip-out bin - 15" wide module	+\$131
<b>BBD</b>	box/box - 30" wide module, door - 15" wide module	+\$0
<b>BBF</b>	box/box - 30" wide module, file - 15" wide module	+\$116
<b>DBB</b>	door - 15" wide module, box/box - 30" wide module	+\$0
<b>FBB</b>	file - 15" wide module, box/box - 30" wide module	+\$116
Step 6. Case Material		
<b>L</b>	laminate case material	+\$0
<b>V</b>	veneer case material <input type="checkbox"/> A	+\$2611
Step 7. Front Material		
<b>L</b>	laminate front material	+\$0
<b>V</b>	veneer front material <input type="checkbox"/> A	+\$403
Step 8. Pull Type		
<b>A</b>	arc pull	+\$0
<b>K</b>	bar pull	+\$0
<b>U</b>	flush pull	+\$0
Step 9. False Back Panel		
<b>N</b>	no back panel	+\$0
<b>B</b>	back panel, matches finish of the front panels and drawer fronts	+\$225
Step 10. Lock		
<b>L</b>	lock	+\$0
<b>N</b>	no lock	-\$48

Step 11. Case Finish		
<i>For laminate case material (L)</i>		
<b>76</b>	light brown walnut	+\$0
<b>8Q</b>	folkstone grey	+\$0
<b>91</b>	white	+\$0
<b>98</b>	studio white	+\$0
<b>CL</b>	cool grey neutral	+\$0
<b>G1</b>	graphite	+\$0
<b>HM</b>	natural maple	+\$0
<b>HP</b>	light anigre	+\$0
<b>HX</b>	aged cherry	+\$0
<b>HY</b>	walnut on cherry	+\$0
<b>LA</b>	light ash	+\$0
<b>LBA</b>	clear on ash	+\$0
<b>LBB</b>	oak on ash	+\$0
<b>LBC</b>	walnut on ash	+\$0
<b>LBD</b>	dark brown walnut	+\$0
<b>LBF</b>	neutral twill	+\$0
<b>LBG</b>	sarum twill	+\$0
<b>LBH</b>	earthen twill	+\$0
<b>LBJ</b>	graphite twill	+\$0
<b>LBK</b>	pewter mesh	+\$0
<b>LBL</b>	steel mesh	+\$0
<b>LBM</b>	crisp linen	+\$0
<b>LBN</b>	classic linen	+\$0
<b>LBP</b>	casual linen	+\$0
<b>LBQ</b>	white twill	+\$0
<b>LBR</b>	phantom ecru	+\$0
<b>LBS</b>	phantom cocoa	+\$0
<b>LBU</b>	medium matte walnut	+\$0
<b>LBV</b>	warm grey teak	+\$0
<b>LU</b>	soft white	+\$0
<b>WL</b>	sandstone	+\$0
<b>WN</b>	warm grey neutral	+\$0
<i>For veneer case material (V)</i>		
<b>2U</b>	light brown walnut	+\$0
<b>40</b>	dark brown walnut	+\$0
<b>ED</b>	aged cherry	+\$0
<b>EK</b>	medium red walnut	+\$0
<b>ET</b>	clear on ash	+\$0
<b>EU</b>	oak on ash	+\$0
<b>EV</b>	walnut on ash	+\$0
<b>EW</b>	medium matte walnut	+\$0
<b>UL</b>	natural maple	+\$0
<b>UX</b>	walnut on cherry	+\$0

Credenza with 8" Base, Individual  
2 Module - 45" Wide *continued*

Step 12. Front Finish

*For laminate front material (L)*

<b>76</b>	light brown walnut	+\$0
<b>8Q</b>	folkstone grey	+\$0
<b>91</b>	white	+\$0
<b>98</b>	studio white	+\$0
<b>CL</b>	cool grey neutral	+\$0
<b>G1</b>	graphite	+\$0
<b>HM</b>	natural maple	+\$0
<b>HP</b>	light anigre	+\$0
<b>HX</b>	aged cherry	+\$0
<b>HY</b>	walnut on cherry	+\$0
<b>LA</b>	light ash	+\$0
<b>LBA</b>	clear on ash	+\$0
<b>LBB</b>	oak on ash	+\$0
<b>LBC</b>	walnut on ash	+\$0
<b>LBD</b>	dark brown walnut	+\$0
<b>LBF</b>	neutral twill	+\$0
<b>LBG</b>	sarum twill	+\$0
<b>LBH</b>	earthen twill	+\$0
<b>LBJ</b>	graphite twill	+\$0
<b>LBK</b>	pewter mesh	+\$0
<b>LBL</b>	steel mesh	+\$0
<b>LBM</b>	crisp linen	+\$0
<b>LBN</b>	classic linen	+\$0
<b>LBP</b>	casual linen	+\$0
<b>LBQ</b>	white twill	+\$0
<b>LBR</b>	phantom ecru	+\$0
<b>LBS</b>	phantom cocoa	+\$0
<b>LBU</b>	medium matte walnut	+\$0
<b>LBV</b>	warm grey teak	+\$0
<b>LU</b>	soft white	+\$0
<b>WL</b>	sandstone	+\$0
<b>WN</b>	warm grey neutral	+\$0

*For veneer front material (V)*

<b>2U</b>	light brown walnut	+\$0
<b>40</b>	dark brown walnut	+\$0
<b>ED</b>	aged cherry	+\$0
<b>EK</b>	medium red walnut	+\$0
<b>ET</b>	clear on ash	+\$0
<b>EU</b>	oak on ash	+\$0
<b>EV</b>	walnut on ash	+\$0
<b>EW</b>	medium matte walnut	+\$0
<b>UL</b>	natural maple	+\$0
<b>UX</b>	walnut on cherry	+\$0

Step 13. Pull Finish

*For arc pull (A)*

<b>NH</b>	brushed nickel	+\$0
<b>NK</b>	black nickel	+\$0

Smooth Paint

*For bar pull (K) or flush pull (U)*

<b>8Q</b>	folkstone grey	+\$0
<b>91</b>	white	+\$0
<b>98</b>	studio white	+\$0
<b>G1</b>	graphite	+\$0
<b>WL</b>	sandstone	+\$0

Metallic Paint

*For bar pull (K) or flush pull (U)*

<b>CN</b>	metallic champagne	+\$0
<b>MS</b>	metallic silver	+\$0

Sand Texture Paint

*For bar pull (K) or flush pull (U)*

<b>79</b>	green apple	+\$16
<b>BK</b>	black	+\$16
<b>MY3</b>	yellow oxide	+\$16
<b>RO</b>	red	+\$16
<b>TRQ</b>	turquoise	+\$16

Step 14. Foot Finish

Smooth Paint

<b>8Q</b>	folkstone grey	+\$0
<b>91</b>	white	+\$0
<b>98</b>	studio white	+\$0
<b>CL</b>	cool grey neutral	+\$0
<b>WL</b>	sandstone	+\$0
<b>WN</b>	warm grey neutral	+\$0

Metallic Paint

<b>CN</b>	metallic champagne	+\$0
<b>EH</b>	metallic bronze	+\$0
<b>MS</b>	metallic silver	+\$0

Sand Texture Paint

<b>BK</b>	black	+\$0
<b>G1</b>	graphite	+\$0

Credenza with 8" Base, Individual  
2 Module - 45" Wide *continued*

---

Step 15. Counterweight		
<b>CB</b>	counterweight	+\$0

---

Step 16. Lock Option		
<i>For lock (L)</i>		
<b>KA</b>	keyed alike	+\$0
<b>KC</b>	keyed differently, chrome	+\$0
<b>KD</b>	keyed differently, black	+\$0

Credenza with 8" Base, Individual L2CF.  
3 Module

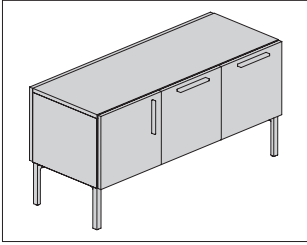

**Product Information**

**Description**

This individual credenza provides 10 configurations of 15"-wide file drawer, cabinet, and tip-out bin modules on 1 side of the unit. It can be used freestanding or with a structural support bracket to support the chase. Options include a lock or no lock and a false back panel. Credenza is available with laminate or veneer case and laminate or veneer fronts and has 8"-high feet with 1 1/2" leveling glides.

**Notes**

Counterweight is required and is specified with each individual storage unit.

File drawers have full-extension slides and accommodate front-to-back filing.

Actual credenza depth is 16 1/2"; actual width is 44 1/2"; actual height is 22".

Order optional accessories separately:

- Structural support, low storage to chase (FG292.1B)

Grain direction is vertical on fronts, sides, and back/false back panel.

For keyed-alike locks, order lock plugs separately. See keyed-alike information in appendices.

Dimensional illustration does not include all possible configurations.

See planning guide for additional configuration information and dimensions.

**Dimensions**

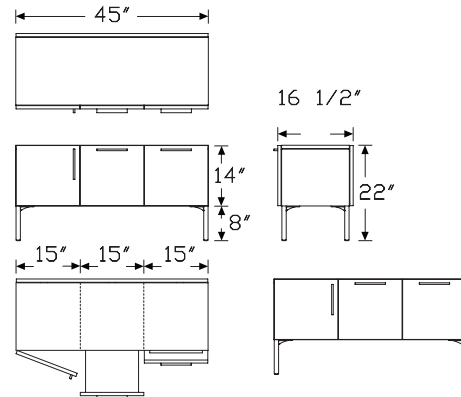

Door, File, Tip-Out Bin

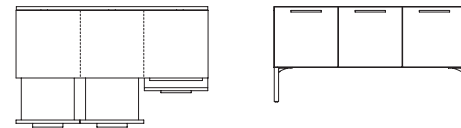

File, File, Tip-Out Bin

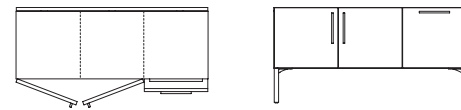

Door, Door, Tip-Out Bin

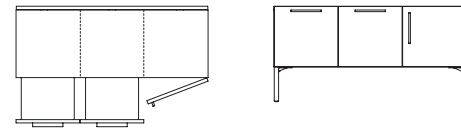

File, File, Door

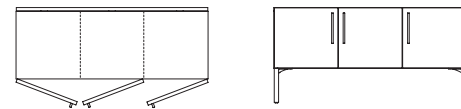

Door, Door, Door

# Credenza with 8" Base, Individual 3 Module *continued*

Specification Information		
Step 1.		
<b>L2CF.83</b>		
Step 2. Width		
<b>45</b>	45" wide	+\$2078
Step 3. Depth		
<b>16</b>	16.5" deep	+\$0
Step 4. Base/Foot Height		
<b>8</b>	8" foot	+\$0
Step 5. Configuration		
<b>FFD</b>	file, file, door - 15" wide modules	+\$242
<b>DFD</b>	door, file, file - 15" wide modules	+\$242
<b>FF2</b>	file, file, tip-out bin - 15" wide modules	+\$366
<b>2FF</b>	tip-out bin, file, file - 15" wide modules	+\$366
<b>FFF</b>	file, file, file - 15" wide modules	+\$361
<b>DDD</b>	door, door, door - 15" wide modules	+\$0
<b>DD2</b>	door, door, tip-out bin - 15" wide modules	+\$131
<b>2DD</b>	tip-out bin, door, door - 15" wide modules	+\$131
<b>DF2</b>	door, file, tip-out bin - 15" wide modules	+\$236
<b>2FD</b>	tip-out bin, file, door - 15" wide modules	+\$236
Step 6. Case Material		
<b>L</b>	laminate case material	+\$0
<b>V</b>	veneer case material <b>A</b>	+\$2611
Step 7. Front Material		
<b>L</b>	laminate front material	+\$0
<b>V</b>	veneer front material <b>A</b>	+\$403
Step 8. Pull Type		
<b>A</b>	arc pull	+\$0
<b>K</b>	bar pull	+\$0
<b>U</b>	flush pull	+\$0
Step 9. False Back Panel		
<b>N</b>	no back panel	+\$0
<b>B</b>	back panel, matches finish of the front panels and drawer fronts	+\$225
Step 10. Lock		
<b>L</b>	lock	+\$0
<b>N</b>	no lock	-\$72

Step 11. Case Finish		
<i>For laminate case material (L)</i>		
<b>76</b>	light brown walnut	+\$0
<b>8Q</b>	folkstone grey	+\$0
<b>91</b>	white	+\$0
<b>98</b>	studio white	+\$0
<b>CL</b>	cool grey neutral	+\$0
<b>G1</b>	graphite	+\$0
<b>HM</b>	natural maple	+\$0
<b>HP</b>	light anigre	+\$0
<b>HX</b>	aged cherry	+\$0
<b>HY</b>	walnut on cherry	+\$0
<b>LA</b>	light ash	+\$0
<b>LBA</b>	clear on ash	+\$0
<b>LBB</b>	oak on ash	+\$0
<b>LBC</b>	walnut on ash	+\$0
<b>LBD</b>	dark brown walnut	+\$0
<b>LBF</b>	neutral twill	+\$0
<b>LBG</b>	sarum twill	+\$0
<b>LBH</b>	earthen twill	+\$0
<b>LBJ</b>	graphite twill	+\$0
<b>LBK</b>	pewter mesh	+\$0
<b>LBL</b>	steel mesh	+\$0
<b>LBM</b>	crisp linen	+\$0
<b>LBN</b>	classic linen	+\$0
<b>LBP</b>	casual linen	+\$0
<b>LBQ</b>	white twill	+\$0
<b>LBR</b>	phantom ecru	+\$0
<b>LBS</b>	phantom cocoa	+\$0
<b>LBU</b>	medium matte walnut	+\$0
<b>LBV</b>	warm grey teak	+\$0
<b>LU</b>	soft white	+\$0
<b>WL</b>	sandstone	+\$0
<b>WN</b>	warm grey neutral	+\$0
<i>For veneer case material (V)</i>		
<b>2U</b>	light brown walnut	+\$0
<b>40</b>	dark brown walnut	+\$0
<b>ED</b>	aged cherry	+\$0
<b>EK</b>	medium red walnut	+\$0
<b>ET</b>	clear on ash	+\$0
<b>EU</b>	oak on ash	+\$0
<b>EV</b>	walnut on ash	+\$0
<b>EW</b>	medium matte walnut	+\$0
<b>UL</b>	natural maple	+\$0
<b>UX</b>	walnut on cherry	+\$0

# Credenza with 8" Base, Individual 3 Module *continued*

## Step 12. Front Finish

### For laminate front material (L)

<b>76</b>	light brown walnut	+\$0
<b>8Q</b>	folkstone grey	+\$0
<b>91</b>	white	+\$0
<b>98</b>	studio white	+\$0
<b>CL</b>	cool grey neutral	+\$0
<b>G1</b>	graphite <b>A</b>	+\$0
<b>HM</b>	natural maple	+\$0
<b>HP</b>	light anigre	+\$0
<b>HX</b>	aged cherry	+\$0
<b>HY</b>	walnut on cherry	+\$0
<b>LA</b>	light ash	+\$0
<b>LBA</b>	clear on ash	+\$0
<b>LBB</b>	oak on ash	+\$0
<b>LBC</b>	walnut on ash	+\$0
<b>LBD</b>	dark brown walnut	+\$0
<b>LBF</b>	neutral twill	+\$0
<b>LBG</b>	sarum twill	+\$0
<b>LBH</b>	earthen twill	+\$0
<b>LBJ</b>	graphite twill	+\$0
<b>LBK</b>	pewter mesh	+\$0
<b>LBL</b>	steel mesh	+\$0
<b>LBM</b>	crisp linen	+\$0
<b>LBN</b>	classic linen	+\$0
<b>LBP</b>	casual linen	+\$0
<b>LBQ</b>	white twill	+\$0
<b>LBR</b>	phantom ecru	+\$0
<b>LBS</b>	phantom cocoa	+\$0
<b>LBU</b>	medium matte walnut	+\$0
<b>LBV</b>	warm grey teak	+\$0
<b>LU</b>	soft white	+\$0
<b>WL</b>	sandstone	+\$0
<b>WN</b>	warm grey neutral	+\$0

### For veneer front material (V)

<b>2U</b>	light brown walnut	+\$0
<b>40</b>	dark brown walnut	+\$0
<b>ED</b>	aged cherry	+\$0
<b>EK</b>	medium red walnut	+\$0
<b>ET</b>	clear on ash	+\$0
<b>EU</b>	oak on ash	+\$0
<b>EV</b>	walnut on ash	+\$0
<b>EW</b>	medium matte walnut	+\$0
<b>UL</b>	natural maple	+\$0
<b>UX</b>	walnut on cherry	+\$0

## Step 13. Pull Finish

### For arc pull (A)

<b>NH</b>	brushed nickel	+\$0
<b>NK</b>	black nickel	+\$0

### Smooth Paint

#### For bar pull (K) or flush pull (U)

<b>8Q</b>	folkstone grey	+\$0
<b>91</b>	white	+\$0
<b>98</b>	studio white	+\$0
<b>G1</b>	graphite	+\$0
<b>WL</b>	sandstone	+\$0

### Metallic Paint

#### For bar pull (K) or flush pull (U)

<b>CN</b>	metallic champagne	+\$0
<b>MS</b>	metallic silver	+\$0

### Sand Texture Paint

#### For bar pull (K) or flush pull (U)

<b>79</b>	green apple	+\$16
<b>BK</b>	black	+\$16
<b>MY3</b>	yellow oxide	+\$16
<b>RO</b>	red	+\$16
<b>TRQ</b>	turquoise	+\$16

## Step 14. Foot Finish

### Smooth Paint

<b>8Q</b>	folkstone grey	+\$0
<b>91</b>	white	+\$0
<b>98</b>	studio white	+\$0
<b>CL</b>	cool grey neutral	+\$0
<b>WL</b>	sandstone	+\$0
<b>WN</b>	warm grey neutral	+\$0

### Metallic Paint

<b>CN</b>	metallic champagne	+\$0
<b>EH</b>	metallic bronze	+\$0
<b>MS</b>	metallic silver	+\$0

### Sand Texture Paint

<b>BK</b>	black	+\$0
<b>G1</b>	graphite	+\$0

## Credenza with 8" Base, Individual 3 Module *continued*

---

### Step 15. Counterweight

*For file, file, door - 15" wide modules (FFD), door, file, file - 15" wide modules (DFF), file, file, tip-out bin - 15" wide modules (FF2), tip-out bin, file, file - 15" wide modules (2FF), file, file, file - 15" wide modules (FFF), door, file, tip-out bin - 15" wide modules (DF2), or tip-out bin, file, door - 15" wide modules (2FD)*

<b>CB</b>	counterweight	+\$0
-----------	---------------	------

---

### Step 16. Lock Option

*For lock (L)*

<b>KA</b>	keyed alike	+\$0
<b>KC</b>	keyed differently, chrome	+\$0
<b>KD</b>	keyed differently, black	+\$0

Credenza with 2" Base, Shared L2CFS.  
Box/File

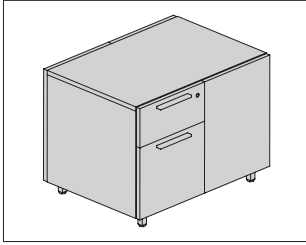

**Product Information**

**Description**

This shared credenza provides a 15"-wide box drawer and file drawer on each side of the unit. It can be used freestanding or with a structural support bracket to support the chase. Credenza is available with laminate or veneer case and laminate or veneer drawer fronts. It has a recessed 2"-high base, base with fronts to floor, or 2"-high feet with 1" leveling glides or casters. False back panel is optional.

**Notes**

Shared storage works best with Canvas Vista™ residing underneath the chase or any benching application between two users.

Box and file drawers have full-extension slides. File drawers accommodate front-to-back filing.

Actual credenza depth is 21<sup>3</sup>/<sub>4</sub>"; actual width is 29<sup>5</sup>/<sub>8</sub>"; actual height is 22".

Order optional accessories separately:

- Structural support, low storage to chase (FG292.1A)
- Add-on cushion top (FF891.)

Grain direction is vertical on front, side, and back panels.

For keyed-alike locks, order lock plugs separately. See keyed-alike information in appendices.

See planning guide for additional configuration information and dimensions.

**Dimensions**

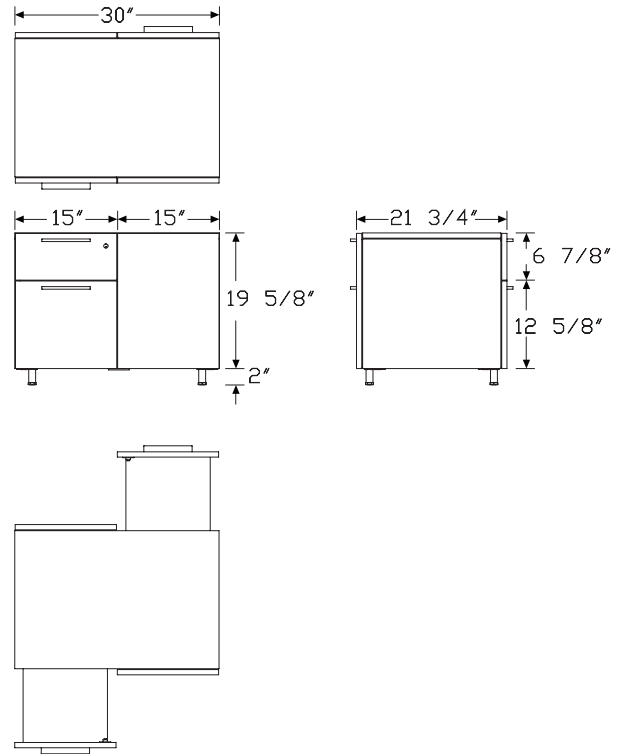

# Credenza with 2" Base, Shared Box/File *continued*

Specification Information		
Step 1.		
<b>L2CFS.22</b>		
Step 2. Width		
<b>30</b>	30" wide	+\$2611
Step 3. Depth		
<b>22</b>	22" deep	+\$0
Step 4. Base/Foot Height		
<b>1</b>	base	+\$22
<b>3</b>	base with fronts to floor	+\$43
<b>5</b>	tube foot	+\$106
<b>9</b>	c-foot	+\$136
Step 5. Configuration		
<b>BFX</b>	box/file, back panel - 15" wide modules	+\$0
Step 6. Case Material		
<b>L</b>	laminate case material	+\$0
<b>V</b>	veneer case material <input type="checkbox"/> A	+\$1984
Step 7. Front Material		
<b>L</b>	laminate front material	+\$0
<b>V</b>	veneer front material <input type="checkbox"/> A	+\$732
Step 8. Pull Type		
<b>A</b>	arc pull	+\$0
<b>K</b>	bar pull	+\$0
<b>U</b>	flush pull	+\$0

Step 9. Case Finish		
<i>For laminate case material (L)</i>		
<b>76</b>	light brown walnut	+\$0
<b>8Q</b>	folkstone grey	+\$0
<b>91</b>	white	+\$0
<b>98</b>	studio white	+\$0
<b>CL</b>	cool grey neutral	+\$0
<b>G1</b>	graphite	+\$0
<b>HM</b>	natural maple	+\$0
<b>HP</b>	light anigre	+\$0
<b>HX</b>	aged cherry	+\$0
<b>HY</b>	walnut on cherry	+\$0
<b>LA</b>	light ash	+\$0
<b>LBA</b>	clear on ash	+\$0
<b>LBB</b>	oak on ash	+\$0
<b>LBC</b>	walnut on ash	+\$0
<b>LBD</b>	dark brown walnut	+\$0
<b>LBF</b>	neutral twill	+\$0
<b>LBG</b>	sarum twill	+\$0
<b>LBH</b>	earthen twill	+\$0
<b>LBJ</b>	graphite twill	+\$0
<b>LBK</b>	pewter mesh	+\$0
<b>LBL</b>	steel mesh	+\$0
<b>LBM</b>	crisp linen	+\$0
<b>LBN</b>	classic linen	+\$0
<b>LBP</b>	casual linen	+\$0
<b>LBQ</b>	white twill	+\$0
<b>LBR</b>	phantom ecru	+\$0
<b>LBS</b>	phantom cocoa	+\$0
<b>LBU</b>	medium matte walnut	+\$0
<b>LBV</b>	warm grey teak	+\$0
<b>LU</b>	soft white	+\$0
<b>WL</b>	sandstone	+\$0
<b>WN</b>	warm grey neutral	+\$0
<b>X1</b>	chalk white	+\$0

Credenza with 2" Base, Shared  
Box/File *continued*

*For veneer case material (V)*

<b>2U</b>	light brown walnut	+\$0
<b>40</b>	dark brown walnut	+\$0
<b>ED</b>	aged cherry	+\$0
<b>EK</b>	medium red walnut	+\$0
<b>EW</b>	medium matte walnut	+\$0
<b>ET</b>	clear on ash	+\$0
<b>EU</b>	oak on ash	+\$0
<b>EV</b>	walnut on ash	+\$0
<b>UL</b>	natural maple	+\$0
<b>UX</b>	walnut on cherry	+\$0

Step 10. Front Finish

*For laminate front material (L)*

<b>76</b>	light brown walnut	+\$0
<b>8Q</b>	folkstone grey	+\$0
<b>91</b>	white	+\$0
<b>98</b>	studio white	+\$0
<b>CL</b>	cool grey neutral	+\$0
<b>G1</b>	graphite	+\$0
<b>HM</b>	natural maple	+\$0
<b>HP</b>	light anigre	+\$0
<b>HX</b>	aged cherry	+\$0
<b>HY</b>	walnut on cherry	+\$0
<b>LA</b>	light ash	+\$0
<b>LBA</b>	clear on ash	+\$0
<b>LBB</b>	oak on ash	+\$0
<b>LBC</b>	walnut on ash	+\$0
<b>LBD</b>	dark brown walnut	+\$0
<b>LBF</b>	neutral twill	+\$0
<b>LBG</b>	sarum twill	+\$0
<b>LBH</b>	earthen twill	+\$0
<b>LBJ</b>	graphite twill	+\$0
<b>LBK</b>	pewter mesh	+\$0
<b>LBL</b>	steel mesh	+\$0
<b>LBM</b>	crisp linen	+\$0
<b>LBN</b>	classic linen	+\$0
<b>LBP</b>	casual linen	+\$0
<b>LBQ</b>	white twill	+\$0
<b>LBR</b>	phantom ecru	+\$0
<b>LBS</b>	phantom cocoa	+\$0
<b>LBU</b>	medium matte walnut	+\$0
<b>LBV</b>	warm grey teak	+\$0
<b>LU</b>	soft white	+\$0
<b>WL</b>	sandstone	+\$0
<b>WN</b>	warm grey neutral	+\$0

*For veneer front material (V)*

<b>2U</b>	light brown walnut	+\$0
<b>40</b>	dark brown walnut	+\$0
<b>ED</b>	aged cherry	+\$0
<b>EK</b>	medium red walnut	+\$0
<b>EW</b>	medium matte walnut	+\$0
<b>ET</b>	clear on ash	+\$0
<b>EU</b>	oak on ash	+\$0
<b>EV</b>	walnut on ash	+\$0
<b>UL</b>	natural maple	+\$0
<b>UX</b>	walnut on cherry	+\$0

Step 11. Pull Finish

*For arc pull (A)*

<b>NH</b>	brushed nickel	+\$0
<b>NK</b>	black nickel	+\$0

Smooth Paint

*For bar pull (K) or flush pull (U)*

<b>8Q</b>	folkstone grey	+\$0
<b>91</b>	white	+\$0
<b>98</b>	studio white	+\$0
<b>G1</b>	graphite	+\$0
<b>WL</b>	sandstone	+\$0

Metallic Paint

*For bar pull (K) or flush pull (U)*

<b>CN</b>	metallic champagne	+\$0
<b>MS</b>	metallic silver	+\$0

Sand Texture Paint

*For bar pull (K) or flush pull (U)*

<b>79</b>	green apple	+\$16
<b>BK</b>	black	+\$16
<b>MY3</b>	yellow oxide	+\$16
<b>RO</b>	red	+\$16
<b>TRQ</b>	turquoise	+\$16

Credenza with 2" Base, Shared  
 Box/File *continued*

Step 12. Foot Finish  
 For tube foot (5) or c-foot (9)

Smooth Paint		
<b>8Q</b>	folkstone grey	+\$0
<b>91</b>	white	+\$0
<b>98</b>	studio white	+\$0
<b>CL</b>	cool grey neutral	+\$0
<b>WL</b>	sandstone	+\$0
<b>WN</b>	warm grey neutral	+\$0

Metallic Paint		
<b>CN</b>	metallic champagne	+\$0
<b>EH</b>	metallic bronze	+\$0
<b>MS</b>	metallic silver	+\$0

Sand Texture Paint		
<b>BK</b>	black	+\$0
<b>G1</b>	graphite	+\$0

Step 13. Lock Option		
<b>KA</b>	keyed alike	+\$0
<b>KC</b>	keyed differently, chrome	+\$0
<b>KD</b>	keyed differently, black	+\$0

Credenza with 2" Base, Shared L2CFS.  
Box/File + Half-Depth Door

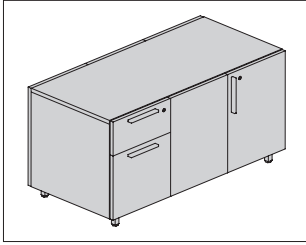

**Product Information**

**Description**

This shared credenza provides 2 configurations of 15"- and 18"-wide box drawer, file drawer, and cabinet modules on each side of the unit. It can be used freestanding or with a structural support bracket to support the chase. Credenza is available with laminate or veneer case and laminate or veneer fronts. It has a recessed 2"-high base, base with fronts to floor, or 2"-high feet with 1" leveling glides or casters. False back panel is optional.

**Notes**

Shared storage works best with Canvas Vista™ residing underneath the chase or any benching application between two users.

Box and file drawers have full-extension slides. File drawers accommodate front-to-back filing.

Actual credenza depth is 21<sup>3</sup>/<sub>4</sub>"; actual height is 22".

Actual credenza widths are:

Nominal—Actual

45" — 44<sup>1</sup>/<sub>2</sub>"

48" — 47<sup>3</sup>/<sub>4</sub>"

Order optional accessories separately:

- Structural support, low storage to chase (FG292.1A)
- Add-on cushion top (FF891.)

Grain direction is vertical on front, side, and back panels.

For keyed-alike locks, order lock plugs separately. See keyed-alike information in appendices.

See planning guide for additional configuration information and dimensions.

**Dimensions**

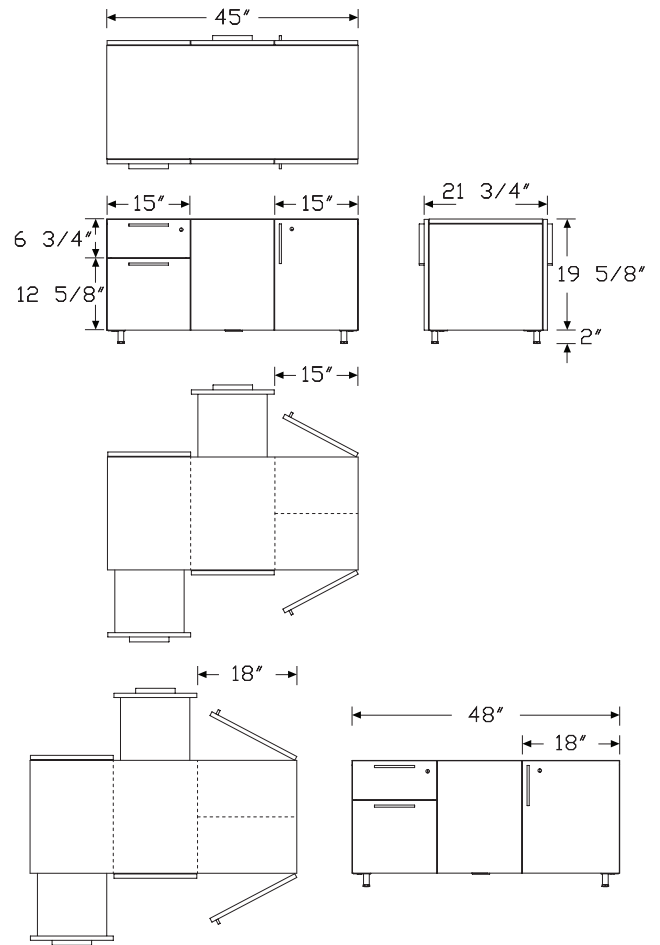

# Credenza with 2" Base, Shared Box/File + Half-Depth Door *continued*

Specification Information		
Step 1.		
<b>L2CFS.23</b>		
Step 2. Width		
<b>45</b>	45" wide	+\$3368
<b>48</b>	48" wide	+\$3393
Step 3. Depth		
<b>22</b>	22" deep	+\$0
Step 4. Base/Foot Height		
<b>1</b>	base	+\$22
<b>3</b>	base with fronts to floor	+\$43
<b>5</b>	tube foot	+\$106
<b>9</b>	c-foot	+\$136
Step 5. Configuration		
<i>For 45" wide (45)</i>		
<b>BX5</b>	box/file, back panel - 15" wide modules, half-depth door - 15" wide module	+\$0
<i>For 48" wide (48)</i>		
<b>BX8</b>	box/file, back panel - 15" wide modules, half-depth door - 18" wide module	+\$0
Step 6. Case Material		
<b>L</b>	laminate case material	+\$0
<b>V</b>	vener case material <input type="checkbox"/> A	+\$2871
Step 7. Front Material		
<b>L</b>	laminate front material	+\$0
<b>V</b>	vener front material <input type="checkbox"/> A	+\$888
Step 8. Pull Type		
<b>A</b>	arc pull	+\$0
<b>K</b>	bar pull	+\$0
<b>U</b>	flush pull	+\$0

Step 9. Case Finish		
<i>For laminate case material (L)</i>		
<b>76</b>	light brown walnut	+\$0
<b>8Q</b>	folkstone grey	+\$0
<b>91</b>	white	+\$0
<b>98</b>	studio white	+\$0
<b>CL</b>	cool grey neutral	+\$0
<b>G1</b>	graphite	+\$0
<b>HM</b>	natural maple	+\$0
<b>HP</b>	light anigre	+\$0
<b>HX</b>	aged cherry	+\$0
<b>HY</b>	walnut on cherry	+\$0
<b>LA</b>	light ash	+\$0
<b>LBA</b>	clear on ash	+\$0
<b>LBB</b>	oak on ash	+\$0
<b>LBC</b>	walnut on ash	+\$0
<b>LBD</b>	dark brown walnut	+\$0
<b>LBF</b>	neutral twill	+\$0
<b>LBG</b>	sarum twill	+\$0
<b>LBH</b>	earthen twill	+\$0
<b>LBJ</b>	graphite twill	+\$0
<b>LBK</b>	pewter mesh	+\$0
<b>LBL</b>	steel mesh	+\$0
<b>LBM</b>	crisp linen	+\$0
<b>LBN</b>	classic linen	+\$0
<b>LBP</b>	casual linen	+\$0
<b>LBQ</b>	white twill	+\$0
<b>LBR</b>	phantom ecru	+\$0
<b>LBS</b>	phantom cocoa	+\$0
<b>LBU</b>	medium matte walnut	+\$0
<b>LBV</b>	warm grey teak	+\$0
<b>LU</b>	soft white	+\$0
<b>WL</b>	sandstone	+\$0
<b>WN</b>	warm grey neutral	+\$0
<i>For veneer case material (V)</i>		
<b>2U</b>	light brown walnut	+\$0
<b>40</b>	dark brown walnut	+\$0
<b>ED</b>	aged cherry	+\$0
<b>EK</b>	medium red walnut	+\$0
<b>EW</b>	medium matte walnut	+\$0
<b>ET</b>	clear on ash	+\$0
<b>EU</b>	oak on ash	+\$0
<b>EV</b>	walnut on ash	+\$0
<b>UL</b>	natural maple	+\$0
<b>UX</b>	walnut on cherry	+\$0

Credenza with 2" Base, Shared  
Box/File + Half-Depth Door *continued*

Step 10. Front Finish

*For laminate front material (L)*

<b>76</b>	light brown walnut	+\$0
<b>8Q</b>	folkstone grey	+\$0
<b>91</b>	white	+\$0
<b>98</b>	studio white	+\$0
<b>CL</b>	cool grey neutral	+\$0
<b>G1</b>	graphite	+\$0
<b>HM</b>	natural maple	+\$0
<b>HP</b>	light anigre	+\$0
<b>HX</b>	aged cherry	+\$0
<b>HY</b>	walnut on cherry	+\$0
<b>LA</b>	light ash	+\$0
<b>LBA</b>	clear on ash	+\$0
<b>LBB</b>	oak on ash	+\$0
<b>LBC</b>	walnut on ash	+\$0
<b>LBD</b>	dark brown walnut	+\$0
<b>LBF</b>	neutral twill	+\$0
<b>LBG</b>	sarum twill	+\$0
<b>LBH</b>	earthen twill	+\$0
<b>LBJ</b>	graphite twill	+\$0
<b>LBK</b>	pewter mesh	+\$0
<b>LBL</b>	steel mesh	+\$0
<b>LBM</b>	crisp linen	+\$0
<b>LBN</b>	classic linen	+\$0
<b>LBP</b>	casual linen	+\$0
<b>LBQ</b>	white twill	+\$0
<b>LBR</b>	phantom ecru	+\$0
<b>LBS</b>	phantom cocoa	+\$0
<b>LBU</b>	medium matte walnut	+\$0
<b>LBV</b>	warm grey teak	+\$0
<b>LU</b>	soft white	+\$0
<b>WL</b>	sandstone	+\$0
<b>WN</b>	warm grey neutral	+\$0
<b>X1</b>	chalk white	+\$0

*For veneer front material (V)*

<b>2U</b>	light brown walnut	+\$0
<b>40</b>	dark brown walnut	+\$0
<b>ED</b>	aged cherry	+\$0
<b>EK</b>	medium red walnut	+\$0
<b>EW</b>	medium matte walnut	+\$0
<b>ET</b>	clear on ash	+\$0
<b>EU</b>	oak on ash	+\$0
<b>EV</b>	walnut on ash	+\$0
<b>UL</b>	natural maple	+\$0
<b>UX</b>	walnut on cherry	+\$0

Step 11. Pull Finish

*For arc pull (A)*

<b>NH</b>	brushed nickel	+\$0
<b>NK</b>	black nickel	+\$0

Smooth Paint

*For bar pull (K) or flush pull (U)*

<b>8Q</b>	folkstone grey	+\$0
<b>91</b>	white	+\$0
<b>98</b>	studio white	+\$0
<b>G1</b>	graphite	+\$0
<b>WL</b>	sandstone	+\$0

Metallic Paint

*For bar pull (K) or flush pull (U)*

<b>CN</b>	metallic champagne	+\$0
<b>MS</b>	metallic silver	+\$0

Sand Texture Paint

*For bar pull (K) or flush pull (U)*

<b>79</b>	green apple	+\$16
<b>BK</b>	black	+\$16
<b>MY3</b>	yellow oxide	+\$16
<b>RO</b>	red	+\$16
<b>TRQ</b>	turquoise	+\$16

Credenza with 2" Base, Shared  
 Box/File + Half-Depth Door *continued*

Step 12. Foot Finish  
 For tube foot (5) or c-foot (9)

Smooth Paint		
<b>8Q</b>	folkstone grey	+\$0
<b>91</b>	white	+\$0
<b>98</b>	studio white	+\$0
<b>CL</b>	cool grey neutral	+\$0
<b>WL</b>	sandstone	+\$0
<b>WN</b>	warm grey neutral	+\$0

Metallic Paint		
<b>CN</b>	metallic champagne	+\$0
<b>EH</b>	metallic bronze	+\$0
<b>MS</b>	metallic silver	+\$0

Sand Texture Paint		
<b>BK</b>	black	+\$0
<b>G1</b>	graphite	+\$0

Step 13. Lock Option		
<b>KA</b>	keyed alike	+\$0
<b>KC</b>	keyed differently, chrome	+\$0
<b>KD</b>	keyed differently, black	+\$0

Credenza with 8" Base, Shared 1 L2CFS.  
Module

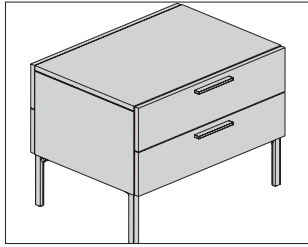

**Product Information**

**Description**

This shared credenza provides a 30"-wide box drawer and tip-out bin module on each side of the unit. It can be used freestanding or with a structural support bracket to support the chase. Credenza is available with laminate or veneer case and laminate or veneer drawer fronts and has 8"-high feet with 1 1/2" leveling glides. Locks are optional.

**Notes**

Shared storage works best with Canvas Vista™ residing underneath the chase or any benching application between two users.

Box drawers have full-extension slides.

Actual credenza depth is 21 3/4"; actual width is 29 7/8"; actual height is 22".

Order optional accessories separately:

- Structural support, low storage to chase (FG292.1A)
- Add-on cushion top (FF891.)

Grain direction is vertical on front and side panels.

For keyed-alike locks, order lock plugs separately. See keyed-alike information in appendices.

See planning guide for additional configuration information and dimensions.

**Dimensions**

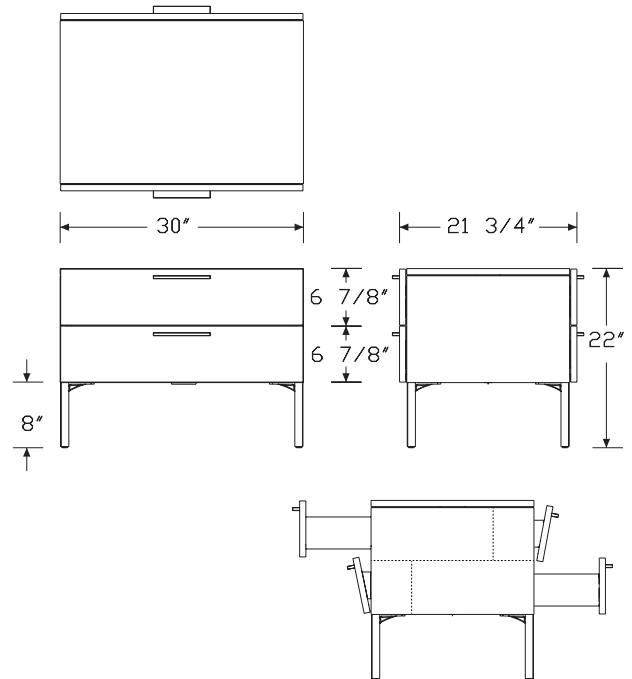

# Credenza with 8" Base, Shared 1 Module *continued*

Canvas Vista™ Storage - Tu® Wood for Canvas Vista™

Specification Information		
Step 1.		
<b>L2CFS.81</b>		
Step 2. Width		
<b>30</b>	30" wide	+\$2924
Step 3. Depth		
<b>22</b>	22" deep	+\$0
Step 4. Base/Foot Height		
<b>8</b>	8" foot	+\$0
Step 5. Configuration		
<b>1B</b>	box/tip-out tray with liner - 30" wide module	+\$0
Step 6. Case Material		
<b>L</b>	laminate case material	+\$0
<b>V</b>	vener case material <input type="checkbox"/> A	+\$1984
Step 7. Front Material		
<b>L</b>	laminate front material	+\$0
<b>V</b>	vener front material <input type="checkbox"/> A	+\$628
Step 8. Pull Type		
<b>A</b>	arc pull	+\$0
<b>K</b>	bar pull	+\$0
<b>U</b>	flush pull	+\$0
Step 9. Lock		
<b>L</b>	lock	+\$0
<b>N</b>	no lock	-\$97

Step 10. Case Finish		
<i>For laminate case material (L)</i>		
<b>76</b>	light brown walnut	+\$0
<b>8Q</b>	folkstone grey	+\$0
<b>91</b>	white	+\$0
<b>98</b>	studio white	+\$0
<b>CL</b>	cool grey neutral	+\$0
<b>G1</b>	graphite	+\$0
<b>HM</b>	natural maple	+\$0
<b>HP</b>	light anigre	+\$0
<b>HX</b>	aged cherry	+\$0
<b>HY</b>	walnut on cherry	+\$0
<b>LA</b>	light ash	+\$0
<b>LBA</b>	clear on ash	+\$0
<b>LBB</b>	oak on ash	+\$0
<b>LBC</b>	walnut on ash	+\$0
<b>LBD</b>	dark brown walnut	+\$0
<b>LBF</b>	neutral twill	+\$0
<b>LBG</b>	sarum twill	+\$0
<b>LBH</b>	earthen twill	+\$0
<b>LBJ</b>	graphite twill	+\$0
<b>LBK</b>	pewter mesh	+\$0
<b>LBL</b>	steel mesh	+\$0
<b>LBM</b>	crisp linen	+\$0
<b>LBN</b>	classic linen	+\$0
<b>LBP</b>	casual linen	+\$0
<b>LBQ</b>	white twill	+\$0
<b>LBR</b>	phantom ecru	+\$0
<b>LBS</b>	phantom cocoa	+\$0
<b>LBU</b>	medium matte walnut	+\$0
<b>LBV</b>	warm grey teak	+\$0
<b>LU</b>	soft white	+\$0
<b>WL</b>	sandstone	+\$0
<b>WN</b>	warm grey neutral	+\$0
<i>For veneer case material (V)</i>		
<b>2U</b>	light brown walnut	+\$0
<b>40</b>	dark brown walnut	+\$0
<b>ED</b>	aged cherry	+\$0
<b>EK</b>	medium red walnut	+\$0
<b>ET</b>	clear on ash	+\$0
<b>EU</b>	oak on ash	+\$0
<b>EV</b>	walnut on ash	+\$0
<b>EW</b>	medium matte walnut	+\$0
<b>UL</b>	natural maple	+\$0
<b>UX</b>	walnut on cherry	+\$0

# Credenza with 8" Base, Shared 1 Module *continued*

## Step 11. Front Finish

### For laminate front material (L)

<b>76</b>	light brown walnut	+\$0
<b>8Q</b>	folkstone grey	+\$0
<b>91</b>	white	+\$0
<b>98</b>	studio white	+\$0
<b>CL</b>	cool grey neutral	+\$0
<b>G1</b>	graphite	+\$0
<b>HM</b>	natural maple	+\$0
<b>HP</b>	light anigre	+\$0
<b>HX</b>	aged cherry	+\$0
<b>HY</b>	walnut on cherry	+\$0
<b>LA</b>	light ash	+\$0
<b>LBA</b>	clear on ash	+\$0
<b>LBB</b>	oak on ash	+\$0
<b>LBC</b>	walnut on ash	+\$0
<b>LBD</b>	dark brown walnut	+\$0
<b>LBF</b>	neutral twill	+\$0
<b>LBG</b>	sarum twill	+\$0
<b>LBH</b>	earthen twill	+\$0
<b>LBJ</b>	graphite twill	+\$0
<b>LBK</b>	pewter mesh	+\$0
<b>LBL</b>	steel mesh	+\$0
<b>LBM</b>	crisp linen	+\$0
<b>LBN</b>	classic linen	+\$0
<b>LBP</b>	casual linen	+\$0
<b>LBQ</b>	white twill	+\$0
<b>LBR</b>	phantom ecru	+\$0
<b>LBS</b>	phantom cocoa	+\$0
<b>LBU</b>	medium matte walnut	+\$0
<b>LBV</b>	warm grey teak	+\$0
<b>LU</b>	soft white	+\$0
<b>WL</b>	sandstone	+\$0
<b>WN</b>	warm grey neutral	+\$0

### For veneer front material (V)

<b>2U</b>	light brown walnut	+\$0
<b>40</b>	dark brown walnut	+\$0
<b>ED</b>	aged cherry	+\$0
<b>EK</b>	medium red walnut	+\$0
<b>ET</b>	clear on ash	+\$0
<b>EU</b>	oak on ash	+\$0
<b>EV</b>	walnut on ash	+\$0
<b>EW</b>	medium matte walnut	+\$0
<b>UL</b>	natural maple	+\$0
<b>UX</b>	walnut on cherry	+\$0

## Step 12. Pull Finish

### For arc pull (A)

<b>NH</b>	brushed nickel	+\$0
<b>NK</b>	black nickel	+\$0

### Smooth Paint

#### For bar pull (K) or flush pull (U)

<b>8Q</b>	folkstone grey	+\$0
<b>91</b>	white	+\$0
<b>98</b>	studio white	+\$0
<b>G1</b>	graphite	+\$0
<b>WL</b>	sandstone	+\$0

### Metallic Paint

#### For bar pull (K) or flush pull (U)

<b>CN</b>	metallic champagne	+\$0
<b>MS</b>	metallic silver	+\$0

### Sand Texture Paint

#### For bar pull (K) or flush pull (U)

<b>79</b>	green apple	+\$16
<b>BK</b>	black	+\$16
<b>MY3</b>	yellow oxide	+\$16
<b>RO</b>	red	+\$16
<b>TRQ</b>	turquoise	+\$16

## Step 13. Foot Finish

### Smooth Paint

<b>8Q</b>	folkstone grey	+\$0
<b>91</b>	white	+\$0
<b>98</b>	studio white	+\$0
<b>CL</b>	cool grey neutral	+\$0
<b>WL</b>	sandstone	+\$0
<b>WN</b>	warm grey neutral	+\$0

### Metallic Paint

<b>CN</b>	metallic champagne	+\$0
<b>EH</b>	metallic bronze	+\$0
<b>MS</b>	metallic silver	+\$0

### Sand Texture Paint

<b>BK</b>	black	+\$0
<b>G1</b>	graphite	+\$0

Credenza with 8" Base, Shared 1  
Module *continued*

---

Step 14. Lock Option

*For lock (L)*

<b>KA</b>	keyed alike	+\$0
<b>KC</b>	keyed differently, chrome	+\$0
<b>KD</b>	keyed differently, black	+\$0

Credenza with 8" Base, Shared 2 L2CFS.  
Module

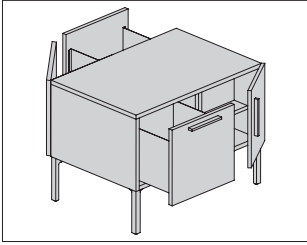

**Product Information**

**Description**

This shared credenza provides 3 configurations of 15"-wide file drawer, cabinet, and medicine cabinet modules on each side of the unit. It can be used freestanding or with a structural support bracket to support the chase. Credenza is available with laminate or veneer case and laminate or veneer fronts and has 8"-high feet with 1/2" leveling glides. Locks are optional.

**Notes**

Shared storage works best with Canvas Vista™ residing underneath the chase or any benching application between two users.

File drawers have full-extension slides and accommodate front-to-back filing.

Actual credenza depth is 21 3/4"; actual width is 29 5/8"; actual height is 22".

Order optional accessories separately:

- Structural support, low storage to chase (FG292.1A)
- Add-on cushion top (FF891.)

Grain direction is vertical on front and side panels.

For keyed-alike locks, order lock plugs separately. See keyed-alike information in appendices.

See planning guide for additional configuration information and dimensions.

**Dimensions**

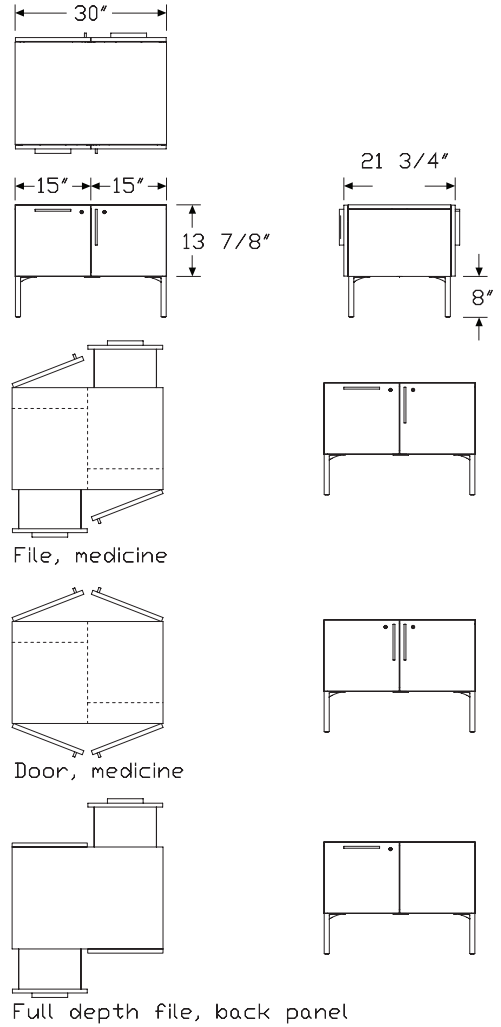

# Credenza with 8" Base, Shared 2 Module *continued*

Specification Information		
Step 1.		
<b>L2CFS.82</b>		
Step 2. Width		
<b>30</b>	30" wide	+\$2266
Step 3. Depth		
<b>22</b>	22" deep	+\$0
Step 4. Base/Foot Height		
<b>8</b>	8" foot	+\$0
Step 5. Configuration		
<b>FX</b>	full depth file, back panel - 15" wide modules	+\$0
<b>FM</b>	file, medicine - 15" wide modules	+\$257
<b>DM</b>	door, medicine - 15" wide modules	+\$85
Step 6. Case Material		
<b>L</b>	laminate case material	+\$0
<b>V</b>	vener case material <b>A</b>	+\$1984
Step 7. Front Material		
<b>L</b>	laminate front material	+\$0
<b>V</b>	vener front material <b>A</b>	+\$628
Step 8. Pull Type		
<b>A</b>	arc pull	+\$0
<b>K</b>	bar pull	+\$0
<b>U</b>	flush pull	+\$0
Step 9. Lock		
<b>L</b>	lock	+\$0
<b>N</b>	no lock	-\$97

Step 10. Case Finish		
<i>For laminate case material (L)</i>		
<b>76</b>	light brown walnut	+\$0
<b>8Q</b>	folkstone grey	+\$0
<b>91</b>	white	+\$0
<b>98</b>	studio white	+\$0
<b>CL</b>	cool grey neutral	+\$0
<b>G1</b>	graphite	+\$0
<b>HM</b>	natural maple	+\$0
<b>HP</b>	light anigre	+\$0
<b>HX</b>	aged cherry	+\$0
<b>HY</b>	walnut on cherry	+\$0
<b>LA</b>	light ash	+\$0
<b>LBA</b>	clear on ash	+\$0
<b>LBB</b>	oak on ash	+\$0
<b>LBC</b>	walnut on ash	+\$0
<b>LBD</b>	dark brown walnut	+\$0
<b>LBF</b>	neutral twill	+\$0
<b>LBG</b>	sarum twill	+\$0
<b>LBH</b>	earthen twill	+\$0
<b>LBJ</b>	graphite twill	+\$0
<b>LBK</b>	pewter mesh	+\$0
<b>LBL</b>	steel mesh	+\$0
<b>LBM</b>	crisp linen	+\$0
<b>LBN</b>	classic linen	+\$0
<b>LBP</b>	casual linen	+\$0
<b>LBQ</b>	white twill	+\$0
<b>LBR</b>	phantom ecru	+\$0
<b>LBS</b>	phantom cocoa	+\$0
<b>LBU</b>	medium matte walnut	+\$0
<b>LBV</b>	warm grey teak	+\$0
<b>LU</b>	soft white	+\$0
<b>WL</b>	sandstone	+\$0
<b>WN</b>	warm grey neutral	+\$0
<i>For veneer case material (V)</i>		
<b>2U</b>	light brown walnut	+\$0
<b>40</b>	dark brown walnut	+\$0
<b>ED</b>	aged cherry	+\$0
<b>EK</b>	medium red walnut	+\$0
<b>ET</b>	clear on ash	+\$0
<b>EU</b>	oak on ash	+\$0
<b>EV</b>	walnut on ash	+\$0
<b>EW</b>	medium matte walnut	+\$0
<b>UL</b>	natural maple	+\$0
<b>UX</b>	walnut on cherry	+\$0

## Credenza with 8" Base, Shared 2 Module *continued*

### Step 11. Front Finish

#### *For laminate front material (L)*

<b>76</b>	light brown walnut	+\$0
<b>8Q</b>	folkstone grey	+\$0
<b>91</b>	white	+\$0
<b>98</b>	studio white	+\$0
<b>CL</b>	cool grey neutral	+\$0
<b>G1</b>	graphite	+\$0
<b>HM</b>	natural maple	+\$0
<b>HP</b>	light anigre	+\$0
<b>HX</b>	aged cherry	+\$0
<b>HY</b>	walnut on cherry	+\$0
<b>LA</b>	light ash	+\$0
<b>LBA</b>	clear on ash	+\$0
<b>LBB</b>	oak on ash	+\$0
<b>LBC</b>	walnut on ash	+\$0
<b>LBD</b>	dark brown walnut	+\$0
<b>LBF</b>	neutral twill	+\$0
<b>LBG</b>	sarum twill	+\$0
<b>LBH</b>	earthen twill	+\$0
<b>LBJ</b>	graphite twill	+\$0
<b>LBK</b>	pewter mesh	+\$0
<b>LBL</b>	steel mesh	+\$0
<b>LBM</b>	crisp linen	+\$0
<b>LBN</b>	classic linen	+\$0
<b>LBP</b>	casual linen	+\$0
<b>LBQ</b>	white twill	+\$0
<b>LBR</b>	phantom ecru	+\$0
<b>LBS</b>	phantom cocoa	+\$0
<b>LBU</b>	medium matte walnut	+\$0
<b>LBV</b>	warm grey teak	+\$0
<b>LU</b>	soft white	+\$0
<b>WL</b>	sandstone	+\$0
<b>WN</b>	warm grey neutral	+\$0

#### *For veneer front material (V)*

<b>2U</b>	light brown walnut	+\$0
<b>40</b>	dark brown walnut	+\$0
<b>ED</b>	aged cherry	+\$0
<b>EK</b>	medium red walnut	+\$0
<b>ET</b>	clear on ash	+\$0
<b>EU</b>	oak on ash	+\$0
<b>EV</b>	walnut on ash	+\$0
<b>EW</b>	medium matte walnut	+\$0
<b>UL</b>	natural maple	+\$0
<b>UX</b>	walnut on cherry	+\$0

### Step 12. Pull Finish

#### *For arc pull (A)*

<b>NH</b>	brushed nickel	+\$0
<b>NK</b>	black nickel	+\$0

#### Smooth Paint

#### *For bar pull (K) or flush pull (U)*

<b>8Q</b>	folkstone grey	+\$0
<b>91</b>	white	+\$0
<b>98</b>	studio white	+\$0
<b>G1</b>	graphite	+\$0
<b>WL</b>	sandstone	+\$0

#### Metallic Paint

#### *For bar pull (K) or flush pull (U)*

<b>CN</b>	metallic champagne	+\$0
<b>MS</b>	metallic silver	+\$0

#### Sand Texture Paint

#### *For bar pull (K) or flush pull (U)*

<b>79</b>	green apple	+\$16
<b>BK</b>	black	+\$16
<b>MY3</b>	yellow oxide	+\$16
<b>RO</b>	red	+\$16
<b>TRQ</b>	turquoise	+\$16

### Step 13. Foot Finish

#### Smooth Paint

<b>8Q</b>	folkstone grey	+\$0
<b>91</b>	white	+\$0
<b>98</b>	studio white	+\$0
<b>CL</b>	cool grey neutral	+\$0
<b>WL</b>	sandstone	+\$0
<b>WN</b>	warm grey neutral	+\$0

#### Metallic Paint

<b>CN</b>	metallic champagne	+\$0
<b>EH</b>	metallic bronze	+\$0
<b>MS</b>	metallic silver	+\$0

#### Sand Texture Paint

<b>BK</b>	black	+\$0
<b>G1</b>	graphite	+\$0

Credenza with 8" Base, Shared 2  
Module *continued*

---

Step 14. Lock Option

*For lock (L)*

<b>KA</b>	keyed alike	+\$0
<b>KC</b>	keyed differently, chrome	+\$0
<b>KD</b>	keyed differently, black	+\$0

Credenza with 8" Base, Shared 2 L2CFS.  
Module - 45" Wide

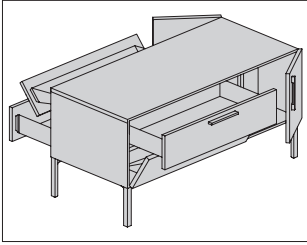

**Product Information**

**Description**

This shared credenza provides 2 configurations of 15"- and 30"-wide box drawer, tip-out tray, cabinet, and tip-out bin modules on each side of the unit. It can be used freestanding or with a structural support bracket to support the chase. Credenza is available with laminate or veneer case and laminate or veneer fronts and has 8"-high feet with 1½" leveling glides. Locks are optional.

**Notes**

Shared storage works best with Canvas Vista™ residing underneath the chase or any benching application between two users.

Box drawers have full-extension slides.

Actual credenza depth is 21¾"; actual width is 44¾"; actual height is 22".

Order optional accessories separately:

- Structural support, low storage to chase (FG292.1A)
- Add-on cushion top (FF891.)

Grain direction is vertical on front and side panels.

For keyed-alike locks, order lock plugs separately. See keyed-alike information in appendices.

See planning guide for additional configuration information and dimensions.

**Dimensions**

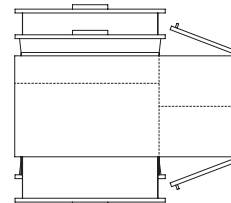
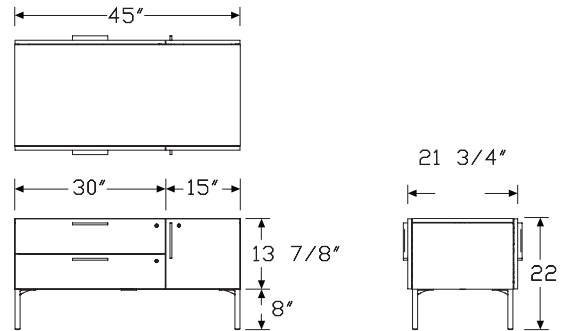

Box/Tip-out tray, half-depth door

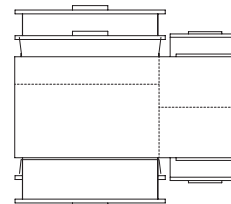

Box/Tip-out tray, tip-out bin

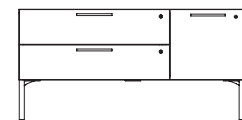
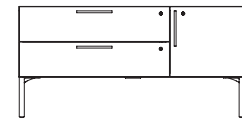

# Credenza with 8" Base, Shared 2 Module - 45" Wide *continued*

Canvas Vista™ Storage - Tu® Wood for Canvas Vista™

Specification Information		
Step 1.		
<b>L2CFS.82</b>		
Step 2. Width		
<b>45</b>	45" wide	+\$3560
Step 3. Depth		
<b>22</b>	22" deep	+\$0
Step 4. Base/Foot Height		
<b>8</b>	8" foot	+\$0
Step 5. Configuration		
<b>1B2</b>	box/tip-out tray with liner - 30" wide module, tip-out bin - 15" wide module	+\$242
<b>1BD</b>	box/tip-out tray with liner - 30" wide module, half-depth door- 15" wide module	+\$0
Step 6. Case Material		
<b>L</b>	laminate case material	+\$0
<b>V</b>	veneer case material <b>A</b>	+\$2245
Step 7. Front Material		
<b>L</b>	laminate front material	+\$0
<b>V</b>	veneer front material <b>A</b>	+\$784
Step 8. Pull Type		
<b>A</b>	arc pull	+\$0
<b>K</b>	bar pull	+\$0
<b>U</b>	flush pull	+\$0
Step 9. Lock		
<b>L</b>	lock	+\$0
<b>N</b>	no lock	-\$145

Step 10. Case Finish		
<i>For laminate case material (L)</i>		
<b>76</b>	light brown walnut	+\$0
<b>8Q</b>	folkstone grey	+\$0
<b>91</b>	white	+\$0
<b>98</b>	studio white	+\$0
<b>CL</b>	cool grey neutral	+\$0
<b>G1</b>	graphite	+\$0
<b>HM</b>	natural maple	+\$0
<b>HP</b>	light anigre	+\$0
<b>HX</b>	aged cherry	+\$0
<b>HY</b>	walnut on cherry	+\$0
<b>LA</b>	light ash	+\$0
<b>LBA</b>	clear on ash	+\$0
<b>LBB</b>	oak on ash	+\$0
<b>LBC</b>	walnut on ash	+\$0
<b>LBD</b>	dark brown walnut	+\$0
<b>LBF</b>	neutral twill	+\$0
<b>LBG</b>	sarum twill	+\$0
<b>LBH</b>	earthen twill	+\$0
<b>LBJ</b>	graphite twill	+\$0
<b>LBK</b>	pewter mesh	+\$0
<b>LBL</b>	steel mesh	+\$0
<b>LBM</b>	crisp linen	+\$0
<b>LBN</b>	classic linen	+\$0
<b>LBP</b>	casual linen	+\$0
<b>LBQ</b>	white twill	+\$0
<b>LBR</b>	phantom ecru	+\$0
<b>LBS</b>	phantom cocoa	+\$0
<b>LBU</b>	medium matte walnut	+\$0
<b>LBV</b>	warm grey teak	+\$0
<b>LU</b>	soft white	+\$0
<b>WL</b>	sandstone	+\$0
<b>WN</b>	warm grey neutral	+\$0
<i>For veneer case material (V)</i>		
<b>2U</b>	light brown walnut	+\$0
<b>40</b>	dark brown walnut	+\$0
<b>ED</b>	aged cherry	+\$0
<b>EK</b>	medium red walnut	+\$0
<b>ET</b>	clear on ash	+\$0
<b>EU</b>	oak on ash	+\$0
<b>EV</b>	walnut on ash	+\$0
<b>EW</b>	medium matte walnut	+\$0
<b>UL</b>	natural maple	+\$0
<b>UX</b>	walnut on cherry	+\$0

## Credenza with 8" Base, Shared 2 Module - 45" Wide *continued*

### Step 11. Front Finish

#### For laminate front material (L)

<b>76</b>	light brown walnut	+\$0
<b>8Q</b>	folkstone grey	+\$0
<b>91</b>	white	+\$0
<b>98</b>	studio white	+\$0
<b>CL</b>	cool grey neutral	+\$0
<b>G1</b>	graphite	+\$0
<b>HM</b>	natural maple	+\$0
<b>HP</b>	light anigre	+\$0
<b>HX</b>	aged cherry	+\$0
<b>HY</b>	walnut on cherry	+\$0
<b>LA</b>	light ash	+\$0
<b>LBA</b>	clear on ash	+\$0
<b>LBB</b>	oak on ash	+\$0
<b>LBC</b>	walnut on ash	+\$0
<b>LBD</b>	dark brown walnut	+\$0
<b>LBF</b>	neutral twill	+\$0
<b>LBG</b>	sarum twill	+\$0
<b>LBH</b>	earthen twill	+\$0
<b>LBJ</b>	graphite twill	+\$0
<b>LBK</b>	pewter mesh	+\$0
<b>LBL</b>	steel mesh	+\$0
<b>LBM</b>	crisp linen	+\$0
<b>LBN</b>	classic linen	+\$0
<b>LBP</b>	casual linen	+\$0
<b>LBQ</b>	white twill	+\$0
<b>LBR</b>	phantom ecru	+\$0
<b>LBS</b>	phantom cocoa	+\$0
<b>LBU</b>	medium matte walnut	+\$0
<b>LBV</b>	warm grey teak	+\$0
<b>LU</b>	soft white	+\$0
<b>WL</b>	sandstone	+\$0
<b>WN</b>	warm grey neutral	+\$0

#### For veneer front material (V)

<b>2U</b>	light brown walnut	+\$0
<b>40</b>	dark brown walnut	+\$0
<b>ED</b>	aged cherry	+\$0
<b>EK</b>	medium red walnut	+\$0
<b>ET</b>	clear on ash	+\$0
<b>EU</b>	oak on ash	+\$0
<b>EV</b>	walnut on ash	+\$0
<b>EW</b>	medium matte walnut	+\$0
<b>UL</b>	natural maple	+\$0
<b>UX</b>	walnut on cherry	+\$0

### Step 12. Pull Finish

#### For arc pull (A)

<b>NH</b>	brushed nickel	+\$0
<b>NK</b>	black nickel	+\$0

#### Smooth Paint

#### For bar pull (K) or flush pull (U)

<b>8Q</b>	folkstone grey	+\$0
<b>91</b>	white	+\$0
<b>98</b>	studio white	+\$0
<b>G1</b>	graphite	+\$0
<b>WL</b>	sandstone	+\$0

#### Metallic Paint

#### For bar pull (K) or flush pull (U)

<b>CN</b>	metallic champagne	+\$0
<b>MS</b>	metallic silver	+\$0

#### Sand Texture Paint

#### For bar pull (K) or flush pull (U)

<b>79</b>	green apple	+\$16
<b>BK</b>	black	+\$16
<b>MY3</b>	yellow oxide	+\$16
<b>RO</b>	red	+\$16
<b>TRQ</b>	turquoise	+\$16

### Step 13. Foot Finish

#### Smooth Paint

<b>8Q</b>	folkstone grey	+\$0
<b>91</b>	white	+\$0
<b>98</b>	studio white	+\$0
<b>CL</b>	cool grey neutral	+\$0
<b>WL</b>	sandstone	+\$0
<b>WN</b>	warm grey neutral	+\$0

#### Metallic Paint

<b>CN</b>	metallic champagne	+\$0
<b>EH</b>	metallic bronze	+\$0
<b>MS</b>	metallic silver	+\$0

#### Sand Texture Paint

<b>BK</b>	black	+\$0
<b>G1</b>	graphite	+\$0

Credenza with 8" Base, Shared 2  
Module - 45" Wide *continued*

---

Step 14. Lock Option

*For lock (L)*

<b>KA</b>	keyed alike	+\$0
<b>KC</b>	keyed differently, chrome	+\$0
<b>KD</b>	keyed differently, black	+\$0

# Credenza with 8" Base, Shared 3 L2CFS. Module

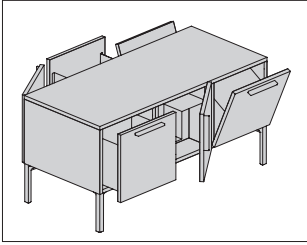

## Product Information

### Description

This shared credenza provides 6 configurations of 15"-wide file drawer, cabinet, tip-out bin, and medicine cabinet modules on each side of the unit. It can be used freestanding or with a structural support bracket to support the chase. Credenza is available with laminate or veneer case and laminate or veneer fronts and has 8"-high feet with 1/2" leveling glides. Locks are optional.

### Notes

Shared storage works best with Canvas Vista™ residing underneath the chase or any benching application between two users.

File drawers have full-extension slides and accommodate front-to-back filing.

Actual credenza depth is 21 3/4"; actual width is 44 1/2"; actual height is 22".

Order optional accessories separately:

- Structural support, low storage to chase (FG292.1A)
- Add-on cushion top (FF891.)

Grain direction is vertical on front and side panels.

For keyed-alike locks, order lock plugs separately. See keyed-alike information in appendices.

See planning guide for additional configuration information and dimensions.

## Dimensions

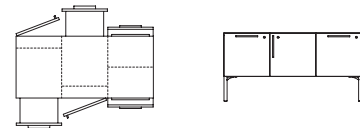
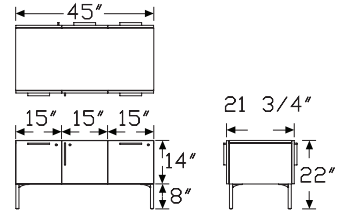

File, Medicine, Tip-Out Bin

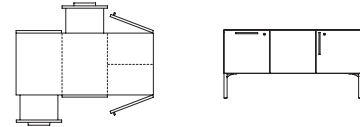

Full-Depth File, Back Panel, Half-Depth Door

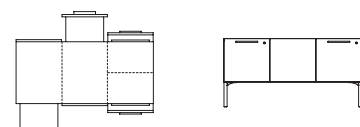

Full-Depth File, Back Panel, Tip-Out Bin

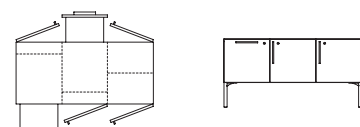

File, Medicine, Half-Depth Door

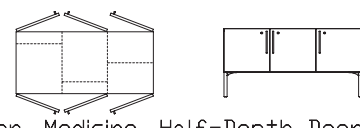

Door, Medicine, Half-Depth Door



Door, Medicine, Tip-Out Bin

# Credenza with 8" Base, Shared 3 Module *continued*

Canvas Vista™ Storage - Tu® Wood for Canvas Vista™

Specification Information		
Step 1.		
<b>L2CFS.83</b>		
Step 2. Width		
<b>45</b>	45" wide	+\$2903
Step 3. Depth		
<b>22</b>	22" deep	+\$0
Step 4. Base/Foot Height		
<b>8</b>	8" foot	+\$0
Step 5. Configuration		
<b>FXD</b>	full-depth file, back panel, half-depth door - 15" wide modules	+\$0
<b>FX2</b>	full-depth file, back panel, tip-out bin - 15" wide modules	+\$242
<b>FMD</b>	file, medicine, half-depth door - 15" wide modules	+\$257
<b>FM2</b>	file, medicine, tip-out bin - 15" wide modules	+\$497
<b>DMD</b>	door, medicine, half-depth door - 15" wide modules	+\$85
<b>DM2</b>	door, medicine, tip-out bin - 15" wide modules	+\$325
Step 6. Case Material		
<b>L</b>	laminate case material	+\$0
<b>V</b>	veneer case material <input type="checkbox"/> A	+\$2245
Step 7. Front Material		
<b>L</b>	laminate front material	+\$0
<b>V</b>	veneer front material <input type="checkbox"/> A	+\$784
Step 8. Pull Type		
<b>A</b>	arc pull	+\$0
<b>K</b>	bar pull	+\$0
<b>U</b>	flush pull	+\$0
Step 9. Lock		
<b>L</b>	lock	+\$0
<b>N</b>	no lock	-\$145

Step 10. Case Finish		
<i>For laminate case material (L)</i>		
<b>76</b>	light brown walnut	+\$0
<b>8Q</b>	folkstone grey	+\$0
<b>91</b>	white	+\$0
<b>98</b>	studio white	+\$0
<b>CL</b>	cool grey neutral	+\$0
<b>G1</b>	graphite	+\$0
<b>HM</b>	natural maple	+\$0
<b>HP</b>	light anigre	+\$0
<b>HX</b>	aged cherry	+\$0
<b>HY</b>	walnut on cherry	+\$0
<b>LA</b>	light ash	+\$0
<b>LBA</b>	clear on ash	+\$0
<b>LBB</b>	oak on ash	+\$0
<b>LBC</b>	walnut on ash	+\$0
<b>LBD</b>	dark brown walnut	+\$0
<b>LBF</b>	neutral twill	+\$0
<b>LBG</b>	sarum twill	+\$0
<b>LBH</b>	earthen twill	+\$0
<b>LBJ</b>	graphite twill	+\$0
<b>LBK</b>	pewter mesh	+\$0
<b>LBL</b>	steel mesh	+\$0
<b>LBM</b>	crisp linen	+\$0
<b>LBN</b>	classic linen	+\$0
<b>LBP</b>	casual linen	+\$0
<b>LBQ</b>	white twill	+\$0
<b>LBR</b>	phantom ecru	+\$0
<b>LBS</b>	phantom cocoa	+\$0
<b>LBU</b>	medium matte walnut	+\$0
<b>LBV</b>	warm grey teak	+\$0
<b>LU</b>	soft white	+\$0
<b>WL</b>	sandstone	+\$0
<b>WN</b>	warm grey neutral	+\$0
<i>For veneer case material (V)</i>		
<b>2U</b>	light brown walnut	+\$0
<b>40</b>	dark brown walnut	+\$0
<b>ED</b>	aged cherry	+\$0
<b>EK</b>	medium red walnut	+\$0
<b>ET</b>	clear on ash	+\$0
<b>EU</b>	oak on ash	+\$0
<b>EV</b>	walnut on ash	+\$0
<b>EW</b>	medium matte walnut	+\$0
<b>UL</b>	natural maple	+\$0
<b>UX</b>	walnut on cherry	+\$0

# Credenza with 8" Base, Shared 3 Module *continued*

## Step 11. Front Finish

### For laminate front material (L)

<b>76</b>	light brown walnut	+\$0
<b>8Q</b>	folkstone grey	+\$0
<b>91</b>	white	+\$0
<b>98</b>	studio white	+\$0
<b>CL</b>	cool grey neutral	+\$0
<b>G1</b>	graphite	+\$0
<b>HM</b>	natural maple	+\$0
<b>HP</b>	light anigre	+\$0
<b>HX</b>	aged cherry	+\$0
<b>HY</b>	walnut on cherry	+\$0
<b>LA</b>	light ash	+\$0
<b>LBA</b>	clear on ash	+\$0
<b>LBB</b>	oak on ash	+\$0
<b>LBC</b>	walnut on ash	+\$0
<b>LBD</b>	dark brown walnut	+\$0
<b>LBF</b>	neutral twill	+\$0
<b>LBG</b>	sarum twill	+\$0
<b>LBH</b>	earthen twill	+\$0
<b>LBJ</b>	graphite twill	+\$0
<b>LBK</b>	pewter mesh	+\$0
<b>LBL</b>	steel mesh	+\$0
<b>LBM</b>	crisp linen	+\$0
<b>LBN</b>	classic linen	+\$0
<b>LBP</b>	casual linen	+\$0
<b>LBQ</b>	white twill	+\$0
<b>LBR</b>	phantom ecru	+\$0
<b>LBS</b>	phantom cocoa	+\$0
<b>LBU</b>	medium matte walnut	+\$0
<b>LBV</b>	warm grey teak	+\$0
<b>LU</b>	soft white	+\$0
<b>WL</b>	sandstone	+\$0
<b>WN</b>	warm grey neutral	+\$0

### For veneer front material (V)

<b>2U</b>	light brown walnut	+\$0
<b>40</b>	dark brown walnut	+\$0
<b>ED</b>	aged cherry	+\$0
<b>EK</b>	medium red walnut	+\$0
<b>ET</b>	clear on ash	+\$0
<b>EU</b>	oak on ash	+\$0
<b>EV</b>	walnut on ash	+\$0
<b>EW</b>	medium matte walnut	+\$0
<b>UL</b>	natural maple	+\$0
<b>UX</b>	walnut on cherry	+\$0

## Step 12. Pull Finish

### For arc pull (A)

<b>NH</b>	brushed nickel	+\$0
<b>NK</b>	black nickel	+\$0

### Smooth Paint

#### For bar pull (K) or flush pull (U)

<b>8Q</b>	folkstone grey	+\$0
<b>91</b>	white	+\$0
<b>98</b>	studio white	+\$0
<b>G1</b>	graphite	+\$0
<b>WL</b>	sandstone	+\$0

### Metallic Paint

#### For bar pull (K) or flush pull (U)

<b>CN</b>	metallic champagne	+\$0
<b>MS</b>	metallic silver	+\$0

### Sand Texture Paint

#### For bar pull (K) or flush pull (U)

<b>79</b>	green apple	+\$16
<b>BK</b>	black	+\$16
<b>MY3</b>	yellow oxide	+\$16
<b>RO</b>	red	+\$16
<b>TRQ</b>	turquoise	+\$16

## Step 13. Foot Finish

### Smooth Paint

<b>8Q</b>	folkstone grey	+\$0
<b>91</b>	white	+\$0
<b>98</b>	studio white	+\$0
<b>CL</b>	cool grey neutral	+\$0
<b>WL</b>	sandstone	+\$0
<b>WN</b>	warm grey neutral	+\$0

### Metallic Paint

<b>CN</b>	metallic champagne	+\$0
<b>EH</b>	metallic bronze	+\$0
<b>MS</b>	metallic silver	+\$0

### Sand Texture Paint

<b>BK</b>	black	+\$0
<b>G1</b>	graphite	+\$0

Credenza with 8" Base, Shared 3  
Module *continued*

---

Step 14. Lock Option

*For lock (L)*

<b>KA</b>	keyed alike	+\$0
<b>KC</b>	keyed differently, chrome	+\$0
<b>KD</b>	keyed differently, black	+\$0

# Suspended Cubby

L2SCF.

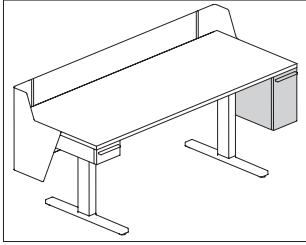

### Product Information

#### Description

This suspended cubby mounts to the underside of a tethered, fixed-height or height-adjustable work surface. It has laminate or veneer case and laminate or veneer fronts. Lock is optional. Felt liner included.

#### Notes

To use the suspended cubby, surface support positions must be inbound.

Suspended cubby is handed, determined from user viewpoint while facing the surface.

When mounting suspended cubby below a height-adjustable table surface, the minimum height of table must be set at a height higher than the components below it.

See planning guide for more information.

#### Dimensions

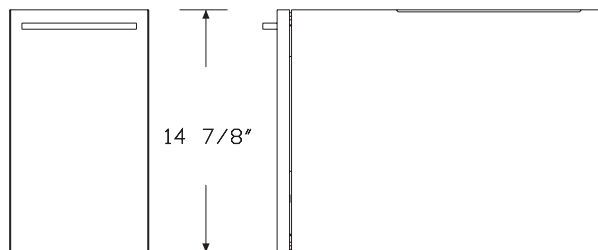
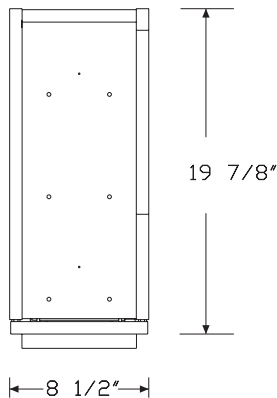

### Specification Information

#### Step 1.

**L2SCF.** [A]

#### Step 2. Type

<b>L</b>	left hand [A]	+\$1081
<b>R</b>	right hand [A]	+\$1081

#### Step 3. Case Material

<b>L</b>	laminate case material [A]	+\$0
<b>V</b>	veneer case material [A]	+\$1160

#### Step 4. Front Material

<b>L</b>	laminate front material [A]	+\$0
<b>V</b>	veneer front material [A]	+\$291

#### Step 5. Pull Type

<b>A</b>	arc pull	+\$0
<b>K</b>	bar pull	+\$0

#### Step 6. Lock

<b>L</b>	lock [A]	+\$0
<b>N</b>	no lock [A]	-\$26

# Suspended Cubby *continued*

## Step 7. Case Finish

### For laminate case material (L)

<b>76</b>	light brown walnut <input type="checkbox"/>	+\$0
<b>8Q</b>	folkstone grey <input type="checkbox"/>	+\$0
<b>91</b>	white <input type="checkbox"/>	+\$0
<b>98</b>	studio white <input type="checkbox"/>	+\$0
<b>CL</b>	cool grey neutral <input type="checkbox"/>	+\$0
<b>G1</b>	graphite <input type="checkbox"/>	+\$0
<b>HM</b>	natural maple <input type="checkbox"/>	+\$0
<b>HP</b>	light anigre <input type="checkbox"/>	+\$0
<b>HX</b>	aged cherry <input type="checkbox"/>	+\$0
<b>HY</b>	walnut on cherry <input type="checkbox"/>	+\$0
<b>LA</b>	light ash <input type="checkbox"/>	+\$0
<b>LBA</b>	clear on ash <input type="checkbox"/>	+\$0
<b>LBB</b>	oak on ash <input type="checkbox"/>	+\$0
<b>LBC</b>	walnut on ash <input type="checkbox"/>	+\$0
<b>LBD</b>	dark brown walnut <input type="checkbox"/>	+\$0
<b>LBF</b>	neutral twill <input type="checkbox"/>	+\$0
<b>LBG</b>	sarum twill <input type="checkbox"/>	+\$0
<b>LBH</b>	earthen twill <input type="checkbox"/>	+\$0
<b>LBJ</b>	graphite twill <input type="checkbox"/>	+\$0
<b>LBK</b>	pewter mesh <input type="checkbox"/>	+\$0
<b>LBL</b>	steel mesh <input type="checkbox"/>	+\$0
<b>LBM</b>	crisp linen <input type="checkbox"/>	+\$0
<b>LBN</b>	classic linen <input type="checkbox"/>	+\$0
<b>LBP</b>	casual linen <input type="checkbox"/>	+\$0
<b>LBQ</b>	white twill <input type="checkbox"/>	+\$0
<b>LBR</b>	phantom ecru <input type="checkbox"/>	+\$0
<b>LBS</b>	phantom cocoa <input type="checkbox"/>	+\$0
<b>LBU</b>	medium matte walnut <input type="checkbox"/>	+\$0
<b>LBV</b>	warm grey teak <input type="checkbox"/>	+\$0
<b>LU</b>	soft white <input type="checkbox"/>	+\$0
<b>WL</b>	sandstone <input type="checkbox"/>	+\$0
<b>WN</b>	warm grey neutral <input type="checkbox"/>	+\$0

### For veneer case material (V)

<b>2U</b>	light brown walnut <input type="checkbox"/>	+\$0
<b>40</b>	dark brown walnut <input type="checkbox"/>	+\$0
<b>ED</b>	aged cherry <input type="checkbox"/>	+\$0
<b>EK</b>	medium red walnut <input type="checkbox"/>	+\$0
<b>ET</b>	clear on ash <input type="checkbox"/>	+\$0
<b>EU</b>	oak on ash <input type="checkbox"/>	+\$0
<b>EV</b>	walnut on ash <input type="checkbox"/>	+\$0
<b>EW</b>	medium matte walnut <input type="checkbox"/>	+\$0
<b>UL</b>	natural maple <input type="checkbox"/>	+\$0
<b>UX</b>	walnut on cherry <input type="checkbox"/>	+\$0

## Step 8. Front Finish

### For laminate front material (L)

<b>76</b>	light brown walnut <input type="checkbox"/>	+\$0
<b>8Q</b>	folkstone grey <input type="checkbox"/>	+\$0
<b>91</b>	white <input type="checkbox"/>	+\$0
<b>98</b>	studio white <input type="checkbox"/>	+\$0
<b>CL</b>	cool grey neutral <input type="checkbox"/>	+\$0
<b>G1</b>	graphite <input type="checkbox"/>	+\$0
<b>HM</b>	natural maple <input type="checkbox"/>	+\$0
<b>HP</b>	light anigre <input type="checkbox"/>	+\$0
<b>HX</b>	aged cherry <input type="checkbox"/>	+\$0
<b>HY</b>	walnut on cherry <input type="checkbox"/>	+\$0
<b>LA</b>	light ash <input type="checkbox"/>	+\$0
<b>LBA</b>	clear on ash <input type="checkbox"/>	+\$0
<b>LBB</b>	oak on ash <input type="checkbox"/>	+\$0
<b>LBC</b>	walnut on ash <input type="checkbox"/>	+\$0
<b>LBD</b>	dark brown walnut <input type="checkbox"/>	+\$0
<b>LBF</b>	neutral twill <input type="checkbox"/>	+\$0
<b>LBG</b>	sarum twill <input type="checkbox"/>	+\$0
<b>LBH</b>	earthen twill <input type="checkbox"/>	+\$0
<b>LBJ</b>	graphite twill <input type="checkbox"/>	+\$0
<b>LBK</b>	pewter mesh <input type="checkbox"/>	+\$0
<b>LBL</b>	steel mesh <input type="checkbox"/>	+\$0
<b>LBM</b>	crisp linen <input type="checkbox"/>	+\$0
<b>LBN</b>	classic linen <input type="checkbox"/>	+\$0
<b>LBP</b>	casual linen <input type="checkbox"/>	+\$0
<b>LBQ</b>	white twill <input type="checkbox"/>	+\$0
<b>LBR</b>	phantom ecru <input type="checkbox"/>	+\$0
<b>LBS</b>	phantom cocoa <input type="checkbox"/>	+\$0
<b>LBU</b>	medium matte walnut <input type="checkbox"/>	+\$0
<b>LBV</b>	warm grey teak <input type="checkbox"/>	+\$0
<b>LU</b>	soft white <input type="checkbox"/>	+\$0
<b>WL</b>	sandstone <input type="checkbox"/>	+\$0
<b>WN</b>	warm grey neutral <input type="checkbox"/>	+\$0

### For veneer front material (V)

<b>2U</b>	light brown walnut <input type="checkbox"/>	+\$0
<b>40</b>	dark brown walnut <input type="checkbox"/>	+\$0
<b>ED</b>	aged cherry <input type="checkbox"/>	+\$0
<b>EK</b>	medium red walnut <input type="checkbox"/>	+\$0
<b>ET</b>	clear on ash <input type="checkbox"/>	+\$0
<b>EU</b>	oak on ash <input type="checkbox"/>	+\$0
<b>EV</b>	walnut on ash <input type="checkbox"/>	+\$0
<b>EW</b>	medium matte walnut <input type="checkbox"/>	+\$0
<b>UL</b>	natural maple <input type="checkbox"/>	+\$0
<b>UX</b>	walnut on cherry <input type="checkbox"/>	+\$0

## Suspended Cubby *continued*

### Step 9. Pull Finish

#### *For arc pull (A)*

<b>NH</b>	brushed nickel	+\$0
<b>NK</b>	black nickel	+\$0

#### Smooth Paint

#### *For bar pull (K)*

<b>8Q</b>	folkstone grey <input type="checkbox"/> A	+\$0
<b>91</b>	white <input type="checkbox"/> A	+\$0
<b>98</b>	studio white <input type="checkbox"/> A	+\$0
<b>G1</b>	graphite <input type="checkbox"/> A	+\$0
<b>WL</b>	sandstone <input type="checkbox"/> A	+\$0

#### Metallic Paint

#### *For bar pull (K)*

<b>CN</b>	metallic champagne <input type="checkbox"/> A	+\$0
<b>MS</b>	metallic silver <input type="checkbox"/> A	+\$0

#### Sand Texture Paint

#### *For bar pull (K)*

<b>79</b>	green apple <input type="checkbox"/> A	+\$16
<b>BK</b>	black <input type="checkbox"/> A	+\$16
<b>MY3</b>	yellow oxide <input type="checkbox"/> A	+\$16
<b>RO</b>	red <input type="checkbox"/> A	+\$16
<b>TRQ</b>	turquoise <input type="checkbox"/> A	+\$16

### Step 10. Lock Option

#### *For lock (L)*

<b>KA</b>	keyed alike	+\$0
<b>KC</b>	keyed differently, chrome	+\$0
<b>KD</b>	keyed differently, black	+\$0

# Suspended Drawer

L2SDF.

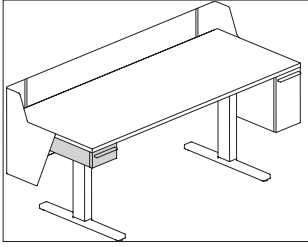

## Product Information

### Description

This suspended drawer mounts to the underside of a tethered, fixed-height or height-adjustable work surface. It has laminate or veneer case and laminate or veneer fronts. Lock is optional. Felt liner included.

### Notes

To use the suspended drawer, surface support positions must be inboard.

Suspended drawer is handed, determined from user viewpoint while facing the surface.

When mounting suspended drawer below a height-adjustable table surface, the minimum height of table must be set at a height higher than the components below it.

See planning guide for more information.

## Dimensions

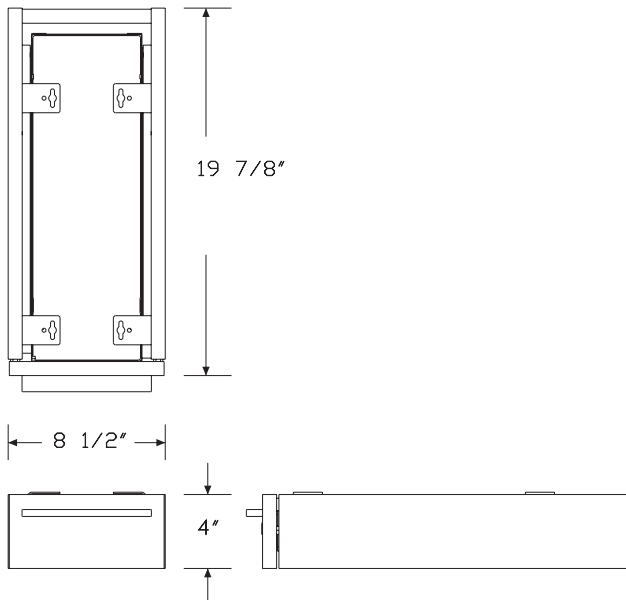

Canvas Vista™ Storage - Tu® Wood for Canvas Vista™

## Specification Information

### Step 1.

**L2SDF.**  A

### Step 2. Type

<b>L</b>	left hand <input type="checkbox"/> A	+\$834
<b>R</b>	right hand <input type="checkbox"/> A	+\$834

### Step 3. Case Material

<b>L</b>	laminate case material <input type="checkbox"/> A	+\$0
<b>V</b>	veneer case material <input type="checkbox"/> A	+\$897

### Step 4. Front Material

<b>L</b>	laminate front material <input type="checkbox"/> A	+\$0
<b>V</b>	veneer front material <input type="checkbox"/> A	+\$212

### Step 5. Pull Type

<b>A</b>	arc pull	+\$0
<b>K</b>	bar pull	+\$0

### Step 6. Lock

<b>L</b>	lock <input type="checkbox"/> A	+\$0
<b>N</b>	no lock <input type="checkbox"/> A	-\$26

# Suspended Drawer *continued*

## Step 7. Case Finish

### *For laminate case material (L)*

<b>76</b>	light brown walnut <input type="checkbox"/>	+\$0
<b>8Q</b>	folkstone grey <input type="checkbox"/>	+\$0
<b>91</b>	white <input type="checkbox"/>	+\$0
<b>98</b>	studio white <input type="checkbox"/>	+\$0
<b>CL</b>	cool grey neutral <input type="checkbox"/>	+\$0
<b>G1</b>	graphite <input type="checkbox"/>	+\$0
<b>HM</b>	natural maple <input type="checkbox"/>	+\$0
<b>HP</b>	light anigre <input type="checkbox"/>	+\$0
<b>HX</b>	aged cherry <input type="checkbox"/>	+\$0
<b>HY</b>	walnut on cherry <input type="checkbox"/>	+\$0
<b>LA</b>	light ash <input type="checkbox"/>	+\$0
<b>LBA</b>	clear on ash <input type="checkbox"/>	+\$0
<b>LBB</b>	oak on ash <input type="checkbox"/>	+\$0
<b>LBC</b>	walnut on ash <input type="checkbox"/>	+\$0
<b>LBD</b>	dark brown walnut <input type="checkbox"/>	+\$0
<b>LBF</b>	neutral twill <input type="checkbox"/>	+\$0
<b>LBG</b>	sarum twill <input type="checkbox"/>	+\$0
<b>LBH</b>	earthen twill <input type="checkbox"/>	+\$0
<b>LBJ</b>	graphite twill <input type="checkbox"/>	+\$0
<b>LBK</b>	pewter mesh <input type="checkbox"/>	+\$0
<b>LBL</b>	steel mesh <input type="checkbox"/>	+\$0
<b>LBM</b>	crisp linen <input type="checkbox"/>	+\$0
<b>LBN</b>	classic linen <input type="checkbox"/>	+\$0
<b>LBP</b>	casual linen <input type="checkbox"/>	+\$0
<b>LBQ</b>	white twill <input type="checkbox"/>	+\$0
<b>LBR</b>	phantom ecru <input type="checkbox"/>	+\$0
<b>LBS</b>	phantom cocoa <input type="checkbox"/>	+\$0
<b>LBU</b>	medium matte walnut <input type="checkbox"/>	+\$0
<b>LBV</b>	warm grey teak <input type="checkbox"/>	+\$0
<b>LU</b>	soft white <input type="checkbox"/>	+\$0
<b>WL</b>	sandstone <input type="checkbox"/>	+\$0
<b>WN</b>	warm grey neutral <input type="checkbox"/>	+\$0

### *For veneer case material (V)*

<b>2U</b>	light brown walnut <input type="checkbox"/>	+\$0
<b>40</b>	dark brown walnut <input type="checkbox"/>	+\$0
<b>ED</b>	aged cherry <input type="checkbox"/>	+\$0
<b>EK</b>	medium red walnut <input type="checkbox"/>	+\$0
<b>ET</b>	clear on ash <input type="checkbox"/>	+\$0
<b>EU</b>	oak on ash <input type="checkbox"/>	+\$0
<b>EV</b>	walnut on ash <input type="checkbox"/>	+\$0
<b>EW</b>	medium matte walnut <input type="checkbox"/>	+\$0
<b>UL</b>	natural maple <input type="checkbox"/>	+\$0
<b>UX</b>	walnut on cherry <input type="checkbox"/>	+\$0

## Step 8. Front Finish

### *For laminate front material (L)*

<b>76</b>	light brown walnut <input type="checkbox"/>	+\$0
<b>8Q</b>	folkstone grey <input type="checkbox"/>	+\$0
<b>91</b>	white <input type="checkbox"/>	+\$0
<b>98</b>	studio white <input type="checkbox"/>	+\$0
<b>CL</b>	cool grey neutral <input type="checkbox"/>	+\$0
<b>G1</b>	graphite <input type="checkbox"/>	+\$0
<b>HM</b>	natural maple <input type="checkbox"/>	+\$0
<b>HP</b>	light anigre <input type="checkbox"/>	+\$0
<b>HX</b>	aged cherry <input type="checkbox"/>	+\$0
<b>HY</b>	walnut on cherry <input type="checkbox"/>	+\$0
<b>LA</b>	light ash <input type="checkbox"/>	+\$0
<b>LBA</b>	clear on ash <input type="checkbox"/>	+\$0
<b>LBB</b>	oak on ash <input type="checkbox"/>	+\$0
<b>LBC</b>	walnut on ash <input type="checkbox"/>	+\$0
<b>LBD</b>	dark brown walnut <input type="checkbox"/>	+\$0
<b>LBF</b>	neutral twill <input type="checkbox"/>	+\$0
<b>LBG</b>	sarum twill <input type="checkbox"/>	+\$0
<b>LBH</b>	earthen twill <input type="checkbox"/>	+\$0
<b>LBJ</b>	graphite twill <input type="checkbox"/>	+\$0
<b>LBK</b>	pewter mesh <input type="checkbox"/>	+\$0
<b>LBL</b>	steel mesh <input type="checkbox"/>	+\$0
<b>LBM</b>	crisp linen <input type="checkbox"/>	+\$0
<b>LBN</b>	classic linen <input type="checkbox"/>	+\$0
<b>LBP</b>	casual linen <input type="checkbox"/>	+\$0
<b>LBQ</b>	white twill <input type="checkbox"/>	+\$0
<b>LBR</b>	phantom ecru <input type="checkbox"/>	+\$0
<b>LBS</b>	phantom cocoa <input type="checkbox"/>	+\$0
<b>LBU</b>	medium matte walnut <input type="checkbox"/>	+\$0
<b>LBV</b>	warm grey teak <input type="checkbox"/>	+\$0
<b>LU</b>	soft white <input type="checkbox"/>	+\$0
<b>WL</b>	sandstone <input type="checkbox"/>	+\$0
<b>WN</b>	warm grey neutral <input type="checkbox"/>	+\$0

### *For veneer front material (V)*

<b>2U</b>	light brown walnut <input type="checkbox"/>	+\$0
<b>40</b>	dark brown walnut <input type="checkbox"/>	+\$0
<b>ED</b>	aged cherry <input type="checkbox"/>	+\$0
<b>EK</b>	medium red walnut <input type="checkbox"/>	+\$0
<b>ET</b>	clear on ash <input type="checkbox"/>	+\$0
<b>EU</b>	oak on ash <input type="checkbox"/>	+\$0
<b>EV</b>	walnut on ash <input type="checkbox"/>	+\$0
<b>EW</b>	medium matte walnut <input type="checkbox"/>	+\$0
<b>UL</b>	natural maple <input type="checkbox"/>	+\$0
<b>UX</b>	walnut on cherry <input type="checkbox"/>	+\$0

## Suspended Drawer *continued*

---

### Step 9. Pull Finish

#### *For arc pull (A)*

<b>NH</b>	brushed nickel	+\$0
<b>NK</b>	black nickel	+\$0

---

#### Smooth Paint

#### *For bar pull (K)*

<b>8Q</b>	folkstone grey <input type="checkbox"/> A	+\$0
<b>91</b>	white <input type="checkbox"/> A	+\$0
<b>98</b>	studio white <input type="checkbox"/> A	+\$0
<b>G1</b>	graphite <input type="checkbox"/> A	+\$0
<b>WL</b>	sandstone <input type="checkbox"/> A	+\$0

---

#### Metallic Paint

#### *For bar pull (K)*

<b>CN</b>	metallic champagne <input type="checkbox"/> A	+\$0
<b>MS</b>	metallic silver <input type="checkbox"/> A	+\$0

---

#### Sand Texture Paint

#### *For bar pull (K)*

<b>79</b>	green apple <input type="checkbox"/> A	+\$16
<b>BK</b>	black <input type="checkbox"/> A	+\$16
<b>MY3</b>	yellow oxide <input type="checkbox"/> A	+\$16
<b>RO</b>	red <input type="checkbox"/> A	+\$16
<b>TRQ</b>	turquoise <input type="checkbox"/> A	+\$16

---

### Step 10. Lock Option

#### *For lock (L)*

<b>KA</b>	keyed alike	+\$0
<b>KC</b>	keyed differently, chrome	+\$0
<b>KD</b>	keyed differently, black	+\$0

# Credenza Cushion Top

FF891.

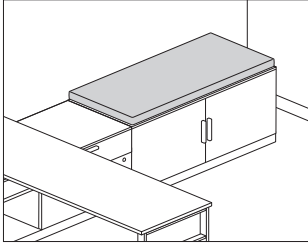

### Product Information

#### Description

This cushion attaches to the top of a metal or wood credenza to provide temporary guest seating. Attachment hardware included.

#### Notes

Cushion accepts Customer's Own Material (COM). Yardage is estimated for nondirectional, 54"-wide fabrics. Order 1 yard of fabric per cushion. For odd number of cushions, round up to next full yard. For information on multiple quantities or directional fabrics, contact COM Department. See Order Information in Appendices.

#### Dimensions

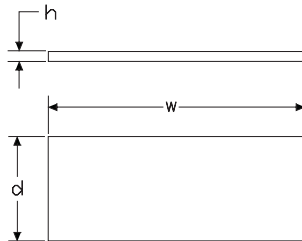

### Specification Information

#### Step 1.

**FF891.**  A

#### Step 2. Height

**01** 1" high  A

**02** 2" high  A

#### Step 3. Depth

**20** 20" deep  A

#### Step 4. Width

**24** 24" wide  A

**30** 30" wide  A

**36** 36" wide  A

**42** 42" wide  A

**48** 48" wide  A

#### Prices for Steps 1-4.

	24	30	36	42	48
<b>FF891. 01 20</b>	\$257	276	296	307	322
<b>02 20</b>	\$308	335	363	385	404

#### Step 5. Fabric

See application chart and textiles list for fabric usage and numbers.

First 2 digits of number indicate fabric line; remaining digit(s) indicate fabric color.

Price Category 1	+\$0
Price Category 2	+\$102
Price Category 3	+\$123
Price Category 4	+\$151
Price Category 5	+\$169
Price Category 7	+\$206
Price Category 8	+\$146
Price Category 9	+\$1425
Price Category (Geiger) 10	+\$1050
Price Category B	+\$71
Price Category C	+\$98
Price Category D	+\$82
Price Category E	+\$150
Price Category F	+\$193
Price Category G	+\$251
Price Category H	+\$305
Price Category I	+\$359
Price Category J	+\$413
Price Category K	+\$310

Credenza Cushion Top *continued*

Step 6. Fabric	
Price Category 1	+\$0
Price Category 2	+\$102
Price Category 3	+\$123
Price Category (Geiger) 3	+\$0
Price Category 4	+\$151
Price Category 5	+\$169
Price Category (Geiger) 5	+\$0
Price Category (Geiger) 6	+\$0
Price Category (Geiger) 7	+\$0
Price Category (Geiger) 8	+\$0
Price Category 9	+\$1425
Price Category (Geiger) 10	+\$1050
Price Category B	+\$71
Price Category C	+\$98
Price Category D	+\$82
Price Category E	+\$150
Price Category F	+\$193
Price Category G	+\$251
Price Category H	+\$305
Price Category I	+\$359
Price Category J	+\$413
Price Category K	+\$310
Price Category L	+\$0
Price Category M	+\$0
Price Category X	+\$0
Price Category Y	+\$0

Step 7. Fabric	
Price Category 1	+\$0
Price Category 2	+\$102
Price Category 3	+\$123
Price Category (Geiger) 3	+\$0
Price Category 4	+\$151
Price Category 5	+\$169
Price Category (Geiger) 5	+\$0
Price Category (Geiger) 6	+\$0
Price Category (Geiger) 7	+\$0
Price Category (Geiger) 8	+\$0
Price Category 9	+\$1425
Price Category (Geiger) 10	+\$1050
Price Category B	+\$71
Price Category C	+\$98
Price Category D	+\$82
Price Category E	+\$150
Price Category F	+\$193
Price Category G	+\$251
Price Category H	+\$305
Price Category I	+\$359
Price Category J	+\$413
Price Category K	+\$310
Price Category X	+\$0
Price Category Y	+\$0

Canvas Vista™ Storage - Tu® Wood for Canvas Vista™

# Index by Product Name

<b>Canvas Vista™</b>	
	page(s)
Bag Hook	109
Cable Management Clip	39
Cable Management Sleeve	41
Cable Manager, Under Chase	40
Café Rectangle	53
Café Round	56
Chase	5
Chase Connector Kit	14
Chase End Cap	6
Chase Shelf	104
Chase to Surface Tether Brackets	59
Chicago Solution	22
Controlled Receptacle, 4-Circuit, 15 Amp (Package of 4)	28
Controlled Receptacle, 20 Amp	30
Credenza Cushion Top	181
Credenza with 2" Base, Individual Box/File	129
Credenza with 2" Base, Individual Box/File + Door	132
Credenza with 2" Base, Shared Box/File	151
Credenza with 2" Base, Shared Box/File + Half-Depth Door	155
Credenza with 8" Base, Individual 1 Module	136
Credenza with 8" Base, Individual 2 Module - 30" Wide	139
Credenza with 8" Base, Individual 2 Module - 45" Wide	143
Credenza with 8" Base, Individual 3 Module	147
Credenza with 8" Base, Shared 1 Module	159
Credenza with 8" Base, Shared 2 Module	163
Credenza with 8" Base, Shared 2 Module - 45" Wide	167
Credenza with 8" Base, Shared 3 Module	171
Data Box, Chase Mounted	33
Display Unit, Chase Attached	66
Flat Edge Screen, Chase Attached	73
Flat Edge Screen, Delineation	102
Flat Edge Screen, Surface Attached	93
Flat Edge Screen, Surface Attached with Modesty	95
Harness with Power + Data Cover	20
Hinged Cable Trough	42
Infeed Cover	32
Infill, Display Unit	69
Laminate Screen, Chase Attached	75
Laminate Screen, Surface Attached	126, 97
Laminate Screen, Surface Attached with Modesty	99
Logic Mini	34
Logic Mini Grommet	36
Magnetic Document Clip	108
Marker Board Screen, Chase Attached	78
Motia® Vista™ Adjustable Base Kit with T-Foot	116
Motia® Vista™ Rectangular Table with T-Foot	111

Moveable Insert	70
Non-Structural Chase Post Leg	10
Open Frame Screen, Chase Attached	65
Open Frame Screen, Surface Attached	82
Pari Screen, Chase Attached	71
Pari Screen, Delineation	101
Pari Screen, Height Adjustable Tables	120
Pari Screen, Surface Attached	89
Pari Screen, Surface Attached with Modesty	91
Peninsula Surface, D-Shaped	47
Peninsula Surface, Round End	50
Power Entry - Ceiling	19
Power Entry, Internal Direct Connect - Floor	15
Power Entry, New York - Floor	17
Power Jumper - Consistent Chase Widths, Chase-to-Chase	23
Power Jumper - Inconsistent Chase Widths, Chase-to-Chase	25
Power Jumper - Within Single Chase	24
Power Plug Strip	37
Receptacle, 4-Circuit, 15 Amp (Package of 4)	27
Receptacle, 20 Amp	29
Receptacle/Data Cover (Package of 2)	31
Rectangular Work Surface	43
Shelf	106
Single Sided Boundary Screen	79
Stiffener	60
Structural Chase A-Leg	7
Structural Chase T-Leg	8
Structural Support, Low Storage to Chase	12
Surface-Attached Screen, Flat Edge	123
Surface Support, A-Leg	61
Surface Support, Post Leg	63
Surface Support, T Leg	62
Suspended Cubby	175
Suspended Drawer	178
T-Light	103
USB Power Module	38
Vista Modesty Screen - Double Sided, Height Adjustable Table	119
Vista Modesty Screen-Double Sided, Surface Attached	87
Vista Modesty Screen-Handed, Surface Attached	83
Vista Privacy + Modesty Screen - Double Sided, Height Adjustable	
Table	118
Vista Privacy + Modesty Screen - Double Sided, Surface Attached	88
Vista Privacy + Modesty Screen - Handed, Surface Attached	85



# Index by Product Number

DV6GTS Motia® Vista™ Rectangular Table with T-Foot	page(s) 111	FG354. Pari Screen, Delineation	101
DV7GT. Motia® Vista™ Adjustable Base Kit with T-Foot	116	FG356. Flat Edge Screen, Surface Attached	93
FF891. Credenza Cushion Top	181	FG357. Flat Edge Screen, Surface Attached with Modesty	95
FG2B1. Surface Support, A-Leg	61	FG358. Flat Edge Screen, Delineation	102
FG2B2. Surface Support, T Leg	62	FG360. Laminate Screen, Surface Attached	97
FG2B3. Surface Support, Post Leg	63	FG361. Laminate Screen, Surface Attached with Modesty	99
FG11A. Structural Chase A-Leg	7	FG430. Moveable Insert	70
FG110. Chase	5	FG491. Infill, Display Unit	69
FG111. Display Unit, Chase Attached	66	FG600. T-Light	103
FG112. Open Frame Screen, Chase Attached	65	FG696. Stiffener	60
FG115. Pari Screen, Chase Attached	71	FGS10. Rectangular Work Surface	43
FG116. Flat Edge Screen, Chase Attached	73	FGS16. Café Round	56
FG117. Non-Structural Chase Post Leg	10	FGS17. Chase Shelf	104
FG118. Marker Board Screen, Chase Attached	78	FGS34. Café Rectangle	53
FG119. Structural Chase T-Leg	8	FGS35. Peninsula Surface, Round End	50
FG120. Laminate Screen, Chase Attached	75	FGS36. Peninsula Surface, D-Shaped	47
FG121. Chase Connector Kit	14	L2CF. Credenza with 2" Base, Individual Box/File	129
FG141. Power Entry, New York - Floor	17	L2CF. Credenza with 2" Base, Individual Box/File + Door	132
FG142. Power Entry - Ceiling	19	L2CF. Credenza with 8" Base, Individual 1 Module	136
FG144. Power Entry, Internal Direct Connect - Floor	15	L2CF. Credenza with 8" Base, Individual 2 Module - 30" Wide	139
FG150. Harness with Power + Data Cover	20	L2CF. Credenza with 8" Base, Individual 2 Module - 45" Wide	143
FG152M Controlled Receptacle, 4-Circuit, 15 Amp (Package of 4)	28	L2CF. Credenza with 8" Base, Individual 3 Module	147
FG152. Receptacle, 4-Circuit, 15 Amp (Package of 4)	27	L2CFS. Credenza with 2" Base, Shared Box/File	151
FG153M Controlled Receptacle, 20 Amp	30	L2CFS. Credenza with 2" Base, Shared Box/File + Half-Depth Door	155
FG153. Receptacle, 20 Amp	29	L2CFS. Credenza with 8" Base, Shared 1 Module	159
FG154. Power Jumper - Consistent Chase Widths, Chase-to-Chase	23	L2CFS. Credenza with 8" Base, Shared 2 Module	163
FG154. Power Jumper - Inconsistent Chase Widths, Chase-to-Chase	25	L2CFS. Credenza with 8" Base, Shared 2 Module - 45" Wide	167
FG154. Power Jumper - Within Single Chase	24	L2CFS. Credenza with 8" Base, Shared 3 Module	171
FG155. Receptacle/Data Cover (Package of 2)	31	L2SCF. Suspended Cubby	175
FG156. Infeed Cover	32	L2SDF. Suspended Drawer	178
FG157. Chicago Solution	22	Y1116. Pari Screen, Height Adjustable Tables	120
FG159. Data Box, Chase Mounted	33	Y1118. Surface-Attached Screen, Flat Edge	123
FG160. Chase End Cap	6	Y1120. Laminate Screen, Surface Attached	126
FG197. Cable Management Clip	39	Y1130. Vista Privacy + Modesty Screen - Double Sided, Height Adjustable Table	118
FG198. Cable Management Sleeve	41	Y1131. Vista Modesty Screen - Double Sided, Height Adjustable Table	119
FG199. Cable Manager, Under Chase	40	Y1300. Hinged Cable Trough	42
FG290. Chase to Surface Tether Brackets	59	Y1412. Logic Mini Grommet	36
FG292. Structural Support, Low Storage to Chase	12	Y1414. Logic Mini	34
FG303. Single Sided Boundary Screen	79	Y1500. Power Plug Strip	37
FG345. Open Frame Screen, Surface Attached	82	YT300. Shelf	106
FG346. Vista Modesty Screen-Handed, Surface Attached	83	YT400. Magnetic Document Clip	108
FG347. Vista Privacy + Modesty Screen - Handed, Surface Attached	85	YT420. USB Power Module	38
FG348. Vista Modesty Screen-Double Sided, Surface Attached	87	YT700. Bag Hook	109
FG349. Vista Privacy + Modesty Screen - Double Sided, Surface Attached	88		
FG351. Pari Screen, Surface Attached	89		
FG353. Pari Screen, Surface Attached with Modesty	91		



# 20-Day or Less/Assigned Lead-Time Order Information

## 20-Day or Less and Assigned Lead-Time Programs

20-day or less and assigned lead-time products are designed for established Herman Miller dealers with pre-approved credit.

Products are distributed from multiple manufacturing facilities across the United States. All products and options not designated by an Assigned Lead-Time icon **A** will ship in 20 business days or less after being acknowledged by Herman Miller. Products and options designated by an **A** are on the assigned lead-time program and will ship in 20 days, less than 20 days, or more than 20 days from order acknowledgement.

## Ordering Procedure

Please place orders through Order Manager. If this is not available to you, place orders through mail or fax. Verbal purchase orders will not be accepted.

Order Entry fax number for Passage®, 5000 Series, and Meridian® Filing and Storage: (616) 846 9236.

Order Entry fax number for all other products:  
(616) 654 3085.

For more information, contact your Customer Care representative at:  
(866) 854 3048 EXT 3400.

## Shipments and Delivery

Per Herman Miller Terms and Conditions.

## Changes and Cancellation

Per Herman Miller Terms and Conditions.



# Keyed-Alike Information

## Keyed-Alike Locks

All components with locks may be specified keyed alike. Products with keyed-alike locks will be shipped with lock chassis installed. Installation of lock cylinders will be on-site according to instructions provided. Herman Miller, Inc., will not be responsible for lock cylinder installation.

When specifying product keyed-alike, include separate lines on your order for the lock cylinders.

**For Action Office®, Ethospace®, Passage®, Quadrant®, Resolve®, and Supplemental products,** list cylinder part number and key number (232092-XXX); select a key number (or numbers) between 226 and 427, excluding numbers 408 and 412.

The following products require a different lock cylinder part number. Specify UKY001-XXX for these products only; select a key number (or numbers) between 226 and 427, excluding numbers 408 and 412.

- A3013.
- A3053.
- G5180.
- G5181.
- G5280.

The keys provided in 232092-XXX and UKY001-XXX kits work with either cylinder type, provided the key numbers match.

**For Tu® Storage, Canvas Office Landscape®, 5000 Series, and Meridian® Storage, see the following charts.**

Keyed-alike locks are field installed.

To order keyed-alike locks for Action Office® Series 1 and 2 door panels, please contact Customer Care.

A master key can be used to open any lock on an attached or freestanding component. In addition, a removal key or lock change tool is required to remove lock plugs. Customers interested in ordering master keys, removal keys, or lock change tools should contact Customer Care.

For Canvas overhead and lower storage units, specify as follows:

Specification Code	Part Number	Color	Lock Series
KA	1B2JK7-XXX <sup>1</sup>	chrome	UM series 226-427

For Canvas Metal Storage, Meridian Storage, Tu Storage, and 5000 Series desk components with pedestals, specify as follows:

Specification Code	Key Number	Color	Lock Series
KA	232092-XXX <sup>1</sup>	black	UM series 226-427
KA	1B2JK7-XXX <sup>1</sup>	chrome	UM series 226-427

For 5000 Series flipper door unit with bezel or credenza storage cabinet with bezel, specify as follows:

Specification Code	Key Number	Color	Lock Series
KA	232092-XXX <sup>1</sup>	black	UM series 226-427

For Canvas Metal Desk overhead units, specify as follows:

Specification Code	Key Number	Color	Lock Series
KA	232092-XXX <sup>1</sup>	black	UM series 226-427
KC	1B2JK7-XXX <sup>1</sup>	chrome	UM series 226-427

### Key Number:

XXX<sup>1</sup> = a key number between 226 and 427 (excluding 408 and 412)

# Vary Easy Program

## Program Overview

Vary Easy is a program designed to help dealers specify standard products with a larger breadth of options. For example, depending on the type of product being specified, choices include additional size, finish, edge types, and cable management features. Vary Easy 3D, specIT, and third-party text-based specification packages support the Vary Easy program. Vary Easy 3D enables designers to create a 3D image, CAD symbols, and a price book page. A Vary Easy product number is assigned for each product as the user selects specific options. Once the product is completely specified, the order can be submitted via Kiosk's Order Manager or a dealer's business system.

## Accessing and Specifying Vary Easy

To view the full product vocabulary, go to the Vary Easy Product Offering on Kiosk. To specify Vary Easy, go to the Vary Easy 3D website on Kiosk, specIT, or your third-party text-based specification package.

Once you've made your product line selection, continue to follow through each option and enter the specific options that represent the product you need. When the product is fully specified, Vary Easy will generate an orderable product number and instantly calculate a price.

*Note: Failure to completely specify a product will cause a delay in order acknowledgements. Be sure to make a selection for all options offered.*

The acknowledgement process for Vary Easy products is the same as for any standard order. Vary Easy products ship with a standardized lead time and are competitively priced.

For more information, contact your Customer Care Line at (866) 854 3048 EXT 3400.

# Proprietary Textiles Application Chart — Workspaces

• Available

**A** Assigned lead-time textile.  
See page 2 for exception notes.

	Action Office® Panels/Connectors	Action Office/Ethospace® B-Style Storage	Action Office B-Style Tackboards	Action Office/Ethospace E-Style Storage	Ethospace Tiles/Connectors	Ethospace/Canvas Office Landscape® Privacy Doors	Canvas Tiles/Extended Width Tiles/Channel Tiles	Canvas B-/E-Style Storage	Canvas Standing Screen and Team Wall Infill	Canvas Tackboards	Canvas Metal Desk Hutch Back Panel	Canvas Vista™ Movable Insert and Display Unit	Layout Studio® Framed Screen	Overlay™ Performance Wall Cladding	Part™ Screens/Flat Edge Screens/Channel Screens	Prospect™ Exterior Acoustic Pad	Public Office Landscape® Screen/Desk Top Divider	Renew™ Link Screens	Exclave® Tackable Boards and Stowage Tackable Backdrop	Exclave Video-Friendly Tackable Boards and Stowage Tackable Backdrop	Personal Side Screen	Tu® Wood Storage Cubby Tackboard	Seating
<b>Price Category 1</b>																							
COM Customer's Own Material <b>A</b>	1	1	1	1	1	1	1	1	1	1	1	1	1	1	1	1	1	1	1	1	1	1	
2V__ Chain	•	•	•	•	•	•	•	•	•	•	•	•	•	•	•	•	•	•	•	•	•	•	
8T__ Crossing (85__)	2	2	2	•	•	•	•	•	•	•	•	•	•	•	•	•	•	•	•	•	•	•	
3DE__ Dex	6	2	2	•	•	•	•	•	•	•	•	•	•	•	•	•	•	•	•	•	•	•	
95__ Gem	2	2	2	•	•	•	•	•	•	•	•	•	•	•	•	•	•	•	•	•	•	•	
2I__ Grasscloth	•	•	•	•	•	•	•	•	•	•	•	•	•	•	•	•	•	•	•	•	•	•	
1MN__ Monologue	2	2	2	•	•	•	•	•	•	•	•	•	•	•	•	•	•	•	•	•	•	•	
5T__ Resonance	•	•	•	•	•	•	•	•	•	•	•	•	•	•	•	•	•	•	•	•	•	•	
2M__ Silkworm	•	•	•	•	•	•	•	•	•	•	•	•	•	•	•	•	•	•	•	•	•	•	
22F__ Slant	6	•	•	•	•	•	•	•	•	•	•	•	•	•	•	•	•	•	•	•	•	•	
235__ Tailored <b>A</b>	•	•	•	•	•	•	•	•	•	•	•	•	•	•	•	•	•	•	•	•	•	•	
1WS__ Whisper	2	2	2	•	•	•	•	•	•	•	•	•	•	•	•	•	•	•	•	•	•	•	
<b>Price Category 2</b>																							
3AR__ Aristo	2	2	2	•	•	•	•	•	•	•	•	•	•	•	•	•	•	•	•	•	•	•	
1CD__ Code	•	•	•	•	•	•	•	•	•	•	•	•	•	•	•	•	•	•	•	•	•	•	
51__ Cord	•	•	•	•	•	•	•	•	•	•	•	•	•	•	•	•	•	•	•	•	•	•	
92__ Crepe	2	•	•	•	•	•	•	•	•	•	•	•	•	•	•	•	•	•	•	•	•	•	
3EP__ Epic	2	2	2	•	•	•	•	•	•	•	•	•	•	•	•	•	•	•	•	•	•	•	
22Q__ Fish Net	•	2	2	•	•	•	•	•	•	•	•	•	•	•	•	•	•	•	•	•	•	•	
57__ Frost	•	•	•	•	•	•	•	•	•	•	•	•	•	•	•	•	•	•	•	•	•	•	
84__ Grosgrain	4	•	•	•	•	•	•	•	•	•	•	•	•	•	•	•	•	•	•	•	•	•	
4N__ Horizon	2	2	2	•	•	•	•	•	•	•	•	•	•	•	•	•	•	•	•	•	•	•	
1LM__ Loom	2	2	2	•	•	•	•	•	•	•	•	•	•	•	•	•	•	•	•	•	•	•	
1HA__ Medley	2	2	2	•	•	•	•	•	•	•	•	•	•	•	•	•	•	•	•	•	•	•	
3RA__ Rain	•	•	•	•	•	•	•	•	•	•	•	•	•	•	•	•	•	•	•	•	•	•	
1RV__ Rivet	2	2	2	•	•	•	•	•	•	•	•	•	•	•	•	•	•	•	•	•	•	•	
3SL__ Sequel	•	2	•	2	•	•	•	•	•	•	•	•	•	•	•	•	•	•	•	•	•	•	
3TW__ Twine	•	•	•	•	•	•	•	•	•	•	•	•	•	•	•	•	•	•	•	•	•	•	
8R__ Twist (5S__)	5	2	2	•	•	•	•	•	•	•	•	•	•	•	•	•	•	•	•	•	•	•	

continued on next page

# Proprietary Textiles Application Chart — Workspaces

continued

	Action Office® Panels/Connectors	Action Office/Ethospace® B-Style Storage	Action Office B-Style Tackboards	Action Office/Ethospace E-Style Storage	Ethospace Tiles/Connectors	Ethospace/Canvas Office Landscape® Privacy Doors	Canvas Tiles/Extended Width Tiles/Channel Tiles	Canvas B-/E-Style Storage	Canvas Standing Screen and Team Wall Infill	Canvas Tackboards	Canvas Metal Desk Hutch Back Panel	Canvas Vista™ Movable Insert and Display Unit	Layout Studio® Framed Screen	Overlay™ Performance Wall Cladding	Pari™ Screens/Flat Edge Screens/Channel Screens	Prospect™ Exterior Acoustic Pad	Public Office Landscape® Screen/Desk Top Divider	Renew™ Link Screens	Exclave® Tackable Boards and Stowage Tackable Backdrop	Exclave Video-Friendly Tackable Boards and Stowage Tackable Backdrop	Personal Side Screen	Tu® Wood Storage Cubby Tackboard	Seating
<b>Price Category 3</b>																							
70__ Bento	2	2	2	•			•	2	•	•	•	•	•	•	•	•	•	•			•	•	
1FC__ Current	•	•	•	•	•	•	•	•	•	•	•	•	•	•	•	•	•	•			•	•	
8Z__ Glaze	•	•	•	•	•	•	•	•	•	•	•	•	•	•	•	•	•	•			•	•	
47__ Ground Cloth®	•	•	•	•	•	•	•	•	•	•	•	•	•	•	•	•	•	•	•	8	•	•	
5D__ Kira 2	2	2	2	•	•	•	•	2	•	•	•	•	•	•	•	•	•	•			•	•	
8L__ Savannah	•	20	•	•	•	•	•	•	•	•	•	•	•	•	•	•	•	•			•	•	
8W__ Strands	•	•	•	•	•	•	•	•	•	•	•	•	•	•	•	•	•	•			•	•	
22V__ String Plaid	2	2	2	•	•	•	•	2	•	•	•	•	•	•	•	•	•	•			•	•	
<b>Price Category 4</b>																							
2X__ Glisten	•	•	•	•	•	•	•	•	•	•	•	•	•	•	•	•	•	•			•	•	
22L__ Loft <sup>A</sup>		2	2	•	•	•	•	2	•	•	•	•	•	•	•	•	•	•	•	8	•	•	
6S__ Quilty	2	2	2	•	•	•	•	2			•	•	•	•	•	•	•	•			•	•	
<b>Price Category 5</b>																							
14A__ Hopsak	2	2	2	•	•	•	•	2	•	•	•	•	•	•					•			•	
<b>Price Category 6</b>																							
No fabrics available at this time.																							

- 1 Refer to price book appendices and Omni for COM information.
- 2 Available on all products except 54" and 60" wide.
- 4 Not available on Action Office (AO) acoustical panels.
- 5 (8R\_\_), (8T\_\_), (85\_\_), and (5S\_\_ ) not available on AO acoustical panels and not available on 54"- or 60"-wide products.
- 6 Not available on Action Office (AO) connectors, cable management, and spacers.
- 8 Available in select colors. See the "Proprietary Textile Colors — Workspaces" appendix.
- 18 Available on seating products in select colors. See the "Proprietary Textile Colors — Seating" appendix.
- 19 Not available in Grosgrain (84\_\_ ) fabric colors 8401, 8405, and 8413.
- 20 Available only on Ethospace B-Style.
- 21 Not available on Ethospace connectors and cable management tiles.
- 22 Not available as railroaded application option for Chain (2Voo) on Canvas Extended Width Tiles.

Application Note: Herman Miller cannot guarantee material/pattern alignment in adjacent products. For example, a fabric's pattern may not align from one screen to the next, or from one panel to the next.

# Proprietary Textile Colors — Workspaces

## Price Category 1

### Customer's Own Material

See Order Information in Appendices.  
Assigned lead-time textile. A

### Chain

66" wide	
100% recycled polyester	
2V01	Pearl
2V02	Oyster
2V03	Wheat
2V04	Linen
2V05	Wicker
2V06	Bamboo
2V07	Sage
2V08	Spring Wood
2V09	Iceberg

### Crossing

54" wide	
86% antimony-free polyester	
14% polyester	
8T03	Wicker *
8T04	Porcelain *
8T05	Warm Grey *
8T06	Sepia
8T07	Pumpkin
8T08	Copper
8T09	Cranberry
8T10	Tomato
8T11	Mulberry
8T12	Plum
8T13	Green Apple
8T14	Loden
8T15	Spruce
8T16	Periwinkle
8T17	Cerulean
8T18	Indigo
8T19	Shale *
8T20	Brownstone
8T21	Bark
8T22	Tin *
8T23	Graphite
8T24	Black

### Crossing

For workspaces products only.  
54" wide  
86% antimony-free polyester  
14% polyester  
8501 Ivory \*  
8502 Oyster \*  
  
\* Colors available on Exclave®  
Video-friendly Tackable  
Boards and Stowage Tackable  
Backdrop

### Dex

54" wide	
50% recycled polyester	
50% polyester	
3DE01	Frost
3DE02	Silver Pine
3DE03	Stone
3DE04	Shale
3DE05	Charcoal

### Gem

54" wide	
100% antimony-free polyester	
9502	Tangerine
9503	Red
9507	Twilight
9508	Bayou
9510	Berry Blue
9511	Aqua Green
9512	Green Apple
9514	Black
9515	Slate Grey
9516	Fog

### Grasscloth

66" wide	
100% recycled polyester	
2I01	Silver Birch
2I02	Pampas
2I03	Sedge
2I07	Lea
2I08	Taro
2I09	Steam Grey
2I10	Cayenne
2I11	Bottle Green
2I12	Surf
2I13	Gravel

### Monologue

54" wide	
56% recycled polyester	
44% polyester	
1MN01	Linen
1MN02	Alabaster
1MN03	Truffle
1MN04	Folkstone
1MN05	Silver Pine
1MN06	Slate
1MN07	Seed
1MN08	Yellow Oxide
1MN09	Persimmon
1MN10	Tundra
1MN11	Meadow
1MN12	Blue Sky
1MN13	Blue Spruce
1MN14	Deep Sea

### Resonance

66" wide	
100% polyester	
5T04	Greige
5T05	Porcelain
5T06	Alabaster
5T15	Iris
5T28	Sugar
5T47	Tobacco
5T54	Saltbush
5T57	Seed
5T58	Sepia
5T60	Iceberg
5T65	Red
5T67	Boysenberry
5T68	Pistachio
5T69	Green Apple
5T71	Jade
5T72	Blue Green
5T74	Twilight

### Silkworm

66" wide	
58% recycled polyester	
42% polyester	
2M01	Cocoon
2M02	Pongee
2M03	Saffron
2M04	Tussah
2M05	Ceylon
2M06	Jasmine
2M07	Shale
2M08	Monsoon

Price category 1 continued on next page

# Proprietary Textile Colors — Workspaces

continued

## Price Category 1

continued

Appendix: Proprietary Textile Colors — Workspaces

Slant	
66" wide	
51% polyester	
49% recycled polyester	

22F04	Pesto
22F06	Neptune
22F07	Blueberry
22F10	Pumpkin
22F12	Silver Birch
22F13	Bluestone
22F15	Shale

Tailored	
Assigned lead-time textile. <span style="border: 1px solid black; padding: 0 2px;">A</span>	
54" wide	
56% polyester	
44% recycled polyester	

23501	Studio White *
23502	Sugar
23503	Tomato
23504	Orchid
23505	Boysenberry
23506	Chive
23507	Bluegrass
23508	Cobalt
23509	Cadet
23510	Fog
23511	Graphite
23512	Black
23513	Coffee

\* Color not available on Canvas Tiles.

Whisper	
54" wide	
73% recycled polyester	
27% polyester	

1WS01	Sand Dollar
1WS02	Pebble
1WS03	Silver Birch
1WS04	Iceberg
1WS05	Silver Pine
1WS06	Carbon
1WS07	Cumin
1WS08	Adobe
1WS09	Strawberry
1WS10	Blush
1WS11	Eggplant
1WS12	Willow
1WS13	Sea Grass
1WS14	Pool
1WS15	Blueberry

## Price Category 2

Aristo	
54" wide	
88% recycled polyester	
12% polyester	

Acrylic backing	
3AR01	Forest Moss
3AR02	Light Brindle
3AR03	Mink
3AR04	Copper
3AR05	Adobe
3AR06	Cherry
3AR07	Lilac
3AR08	Green Apple
3AR09	Surf
3AR10	Waterfall
3AR11	Cadet
3AR12	Tin
3AR13	Pewter
3AR14	Grey Brindle
3AR15	Grey Black

Code	
66" wide	
100% Repreve recycled polyester	

1CD01	Linen
1CD02	Khaki
1CD03	Iceberg
1CD04	Zinc
1CD05	Blue Black

Cord	
66" wide	
51% antimony-free polyester	
49% polyester	

5101	Ivory
5102	White Ash
5103	Linen
5104	Bamboo
5105	Sepia
5106	Wicker
5107	Sesame
5108	Kiwi Green
5109	Bayou
5110	Shade
5111	Spring Wood
5112	Summer White

Crepe	
54" wide	
100% recycled polyester	

9201	Licorice
9203	Smoke
9207	Cherry
9209	Claret
9212	Raisin
9218	Aquamarine
9223	Cadet
9241	Beachglass
9243	Midnight
9244	Artichoke
9248	Warm White *
9249	Stone *
9250	Earth
9251	Fog *
9252	Slate Grey
9253	Yellow Dark
9254	Coral
9255	Blush Grey *
9256	Wild Berry
9257	Clover
9258	Caribbean
9259	Cerulean
9260	Brownstone
9261	Shale
9262	Graphite
9263	Tomato
9264	Green Apple

\* Colors available on Exclave® Video-friendly Tackable Boards and Stowage Tackable Backdrop.

Price category 2 continued on next page

# Proprietary Textile Colors — Workspaces

continued

## Price Category 2

continued

Epic	
54" wide	
56% recycled polyester	
44% polyester	
Acrylic backing	
3EP01	Alabaster
3EP02	Smoke
3EP03	Falcon
3EP04	Citrus Spring
3EP05	Copper
3EP06	Urban Orange
3EP07	Poppy
3EP08	Wild Plum
3EP09	Sugar Plum
3EP10	Clover
3EP11	Loden
3EP12	Everglade
3EP13	Mist
3EP14	Peacock
3EP15	Cadet
3EP16	Indigo
3EP17	Spring Wood
3EP18	Grey Brindle
3EP19	Seed
3EP20	Carbon Dark

Fish Net	
55" wide	
100% recycled polyester	
22Q01	Oyster
22Q02	Stone
22Q03	Citrus
22Q04	Curry
22Q05	Chipotle
22Q06	Cherry
22Q07	Fuschia
22Q08	Claret
22Q09	Purple
22Q10	Clover
22Q11	Pesto
22Q12	Peacock
22Q13	Lagoon
22Q14	Twilight
22Q15	Bluestone
22Q16	Storm
22Q17	Black
22Q18	Cocoa

Frost	
66" wide	
100% recycled polyester	
5703	Porcelain
5704	Honey
5705	Iceberg
5706	Sage
5710	Sable Grey

Grosgrain	
66" wide	
100% recycled polyester	
8401	Pearl * **
8402	White Ash
8403	Warm Grey
8404	Khaki
8405	Oyster *
8406	Celadon
8408	Spa Blue
8409	Bud
8410	Kiwi Green
8411	Bayou
8412	Tin
8413	Iceberg *

\* Colors not available on Canvas Dock Mounted Screens, Locale® Workbase Screen, Public Office Landscape® Screen/Desk Top Divider, and Thrive® Personal Side Screen.

\*\* Color not available on Canvas Tiles.

Horizon	
54" wide	
65% antimony-free polyester	
35% polyester	
4N01	Rye Grass
4N02	Sugar Pine
4N03	Silver Pine
4N04	White Ash
4N05	Spring Wood
4N06	Tamarack
4N07	Mushroom
4N08	Haystack
4N09	Oat Grass
4N10	Forest Moss
4N11	Hickory
4N12	Beech Nut
4N13	Pine Cone
4N14	Poplar
4N15	Elderberry

Loom	
54" wide	
100% polyester	
1LM01	Linen
1LM02	Brown Sugar and Spice
1LM03	Brick and Mortar
1LM04	Salt and Pepper
1LM05	Black
1LM06	Lemongrass
1LM07	Poppy
1LM08	Wild Berry
1LM09	Loden
1LM10	Jade
1LM11	Deep Sea

Medley	
54" wide	
100% polyester	
1HA01	Stone *
1HA02	Trail
1HA03	Charcoal
1HA04	Cinder
1HA05	Citrus
1HA06	Papaya
1HA07	Chutney
1HA08	Tundra
1HA09	Feather Grey *
1HA10	Chartreuse
1HA11	Loden
1HA12	Peacock
1HA13	Bayou *
1HA14	Blue Grotto
1HA15	Blueberry
1HA22	Khaki
1HA23	Pewter
1HA24	Yellow Oxide
1HA25	Vintage Rose
1HA26	Raspberry
1HA27	Acai Berry

\* Colors available on Exclave® Video-friendly Tackable Boards and Stowage Tackable Backdrop

Price category 2 continued on next page

# Proprietary Textile Colors — Workspaces

continued

## Price Category 2

continued

### Rain

66" wide	
100% recycled polyester	
3RA01	Iceberg
3RA02	Frost
3RA03	Pewter
3RA04	Graphite
3RA05	Warm White
3RA06	Linen
3RA07	Rye
3RA08	Light Brindle

### Rivet

54" wide	
100% recycled polyester	
1RV01	Twig
1RV02	Deep Clay
1RV03	Woodrose
1RV04	Otter
1RV05	Hemlock
1RV06	Olive
1RV07	Lagoon
1RV08	Deep Sea
1RV09	Charcoal
1RV10	Grey Brindle

### Sequel

54" wide	
100% vinyl	
100% polyester knit backing	
Resilience® finish	
3SL01	White
3SL02	Pebble
3SL03	Mushroom
3SL04	Stone
3SL05	Chestnut
3SL06	Rattan
3SL07	Black Cherry
3SL08	Tundra
3SL09	Seal
3SL10	Blue Fog
3SL11	Folkstone
3SL12	Shale
3SL13	Slate Grey
3SL14	Charcoal
3SL15	Carbon Dark

### Twine

66" wide	
100% recycled polyester	
3TW01	Silver Birch
3TW02	Ivory
3TW03	Alabaster
3TW04	Bamboo
3TW05	Iceberg
3TW06	Charcoal
3TW07	Feather Grey
3TW08	Shale

### Twist

54" wide	
80% antimony-free polyester	
13% recycled polyester	
7% polyester	
8R05	Wicker
8R10	Poppy
8R14	Tin
8R15	Shale
8R16	Graphite
8R17	Birch
8R18	Sepia
8R22	Blueberry
8R23	Green Apple
8R26	Gunmetal
8R27	Cinder
8R28	Citrus
8R29	Pekoe
8R30	Tangerine
8R31	Red Plum
8R32	Wisteria
8R33	Forest
8R34	Jade Dark
8R35	Waterfall
8R36	Midnight Blue
8R37	Carbon Dark

### Twist

For workspaces products only.	
54" wide	
80% antimony-free polyester	
13% recycled polyester	
7% polyester	
5S01	Pearl
5S02	Ivory
5S03	Oyster

## Price Category 3

### Bento

54" wide	
100% antimony-free polyester	
7001	Frost
7002	Linen
7003	Khaki
7004	Truffle
7005	Grey Black
7006	Pumpkin
7007	Cranberry
7008	Everglade
7009	Cobalt

### Current

66" wide	
100% antimony-free polyester	
1FC1	Oyster
1FC2	Linen
1FC3	Iceberg
1FC4	Silver Pine
1FC5	Apricot
1FC6	Cumin
1FC7	Green Apple
1FC8	Slate Blue
1FC9	Metal

### Glaze

66" wide	
100% recycled polyester	
8Z01	Wicker
8Z02	Honey
8Z03	Porcelain
8Z04	Celadon
8Z06	Rye
8Z07	Frost
8Z08	Silver Birch

Price category 3 continued on next page

# Proprietary Textile Colors — Workspaces

continued

## Price Category 3

continued

Ground Cloth®	
66" wide	
100% polyester	
4701	Vapor Grey
4721	Warm White *
4722	Fog *
4723	Straw *
4724	Red Orange *
4725	Wild Berry *
4726	Green Apple *
4727	Caribbean *
4728	Midnight *
4729	Cappuccino *

\* Colors available on Exclave®  
Video-friendly Tackable Boards  
and Stowage Tackable Backdrop

Kira 2	
54" wide	
100% recycled polyester	
5D11	Flaxen
5D12	Papyrus
5D13	Oasis
5D14	Incense
5D15	Ash
5D16	Falcon

Savannah	
66" wide	
76% recycled polyester	
24% polypropylene	
8L01	Pearl
8L02	Oyster
8L03	Wheat
8L04	Jute
8L05	Bamboo
8L06	Metal
8L07	Linen
8L08	Celadon
8L09	Moss
8L10	Frost
8L11	Shale
8L12	Pewter

Strands	
66" wide	
100% recycled polyester	
8W01	Pebble
8W02	Porcelain
8W03	Taupe
8W04	Honey
8W05	Khaki
8W06	Rye
8W07	Wicker
8W08	Tin
8W09	Cool Grey

String Plaid	
54" wide	
100% recycled polyester	
22V01	Warm White on Khaki
22V02	Mint on Yellow Green
22V03	Mist on Blue Grey
22V04	Sky Blue on Red
22V05	Lime on Magenta
22V06	Bright Green on Green
22V07	Aqua Blue on Cerulean
22V08	Ivory on Black

## Price Category 4

Glisten	
66" wide	
84% polyester	
16% recycled polyester	
2X02	Rye
2X05	Iceberg
2X09	Pewter
2X10	Ash

Loft	
Assigned lead-time textile. <a href="#">A</a>	
54" wide	
100% wool	
22L01	Heathered Light Green
22L02	Heathered Dark Green
22L03	Heathered Turquoise
22L04	Heathered Navy
22L08	Heathered Grey *
22L09	Heathered Blue *
22L11	Heathered Dark Grey

\* Colors available on Exclave®  
Video-friendly Tackable  
Boards and Stowage Tackable  
Backdrop

Quilty	
56" wide	
100% antimony-free polyester	
GreenShield	
6S03	Khaki
6S04	Straw
6S07	Brick
6S10	Mink
6S11	Green Apple
6S13	Indigo
6S14	Zinc
6S15	Slate
6S16	Beachwood
6S17	Paprika
6S18	Plum
6S19	Juniper
6S20	Grey Black

## Price Category 5

Hopsak	
56" wide	
100% recycled polyester	
14A20	Black
14A22	Raw Umber Dark
14A26	Grey Blue Dark
14A30	Sepia Dark
14A38	Emerald Dark
14A39	Yellow Dark
14A40	Orange
14A41	Sienna
14A42	Olive Green Dark
14A43	Crimson
14A44	Crimson Dark Dark
14A45	Violet Dark
14A46	Pink Dark Dark
14A47	Ultramarine Dark
14A48	Cobalt Blue
14A49	Terra Cotta
14A50	Ochre Dark

For more information about our products and services or to see a list of dealers, please visit us at [HermanMiller.com](http://HermanMiller.com) or call (800) 851 1196.

© 2020 Herman Miller, Inc., Zeeland, Michigan

#### Distribution Rights

Working together since 1956, Herman Miller and Vitra are the authentic sources of designs by Charles and Ray Eames, Alexander Girard, and George Nelson. All the designs shown in this book are protected by law. Herman Miller has obtained all rights to make and sell these designs. Also, Herman Miller holds exclusive worldwide manufacturing and distribution rights for these products with the following exceptions:

Charles and Ray Eames, George Nelson, and Alexander Girard—Worldwide distribution rights for furniture in all areas except Europe and the Middle East. For those areas, please contact Vitra.

Isamu Noguchi—Worldwide distribution rights for the Noguchi Rudder Table. Distribution rights for the Noguchi Table in North America and Central America only. For all other areas, please contact Vitra.

Magis—Exclusive distribution rights in the US and Canada. For all other areas, please contact Magis.

Mattiazzi—Exclusive distribution rights in the US and Canada. For all other areas, please contact Mattiazzi.

® **HermanMiller**, ●, 3D Intelligent, AO, Action Office, Aeron, ArcSpan, Aside, Avall, Bubble Lamps, Canvas Office Landscape, Caper, Celle, Co/Struc, Daisyone, Distil, Eames, Eco-Dematerialized, Embody, Envelop, Ethospace, Exclave, Fine-Tune, FlexFront, Flo, Formcoat, Formwork, Ground Cloth, Herman Miller for the Home, Herman Miller for Healthcare, Intersect, Kinemat, Layout Studio, Lifework, Limerick, Live Unframed, Living Office, Locale, Maharam, Meridian, Mirra, Motia, Pellicle, Perspectives, Plex, PostureFit, Public Office Landscape, Resolve, Rodney, Sayl, Setu, Thrive, Tu, Wishbone, and Y-Tower are among the registered trademarks of Herman Miller, Inc., and its owned subsidiaries.

™ 8Z Pellicle, About Face, AireWeave, Albert, Backfit, Bubbletack, Burdick Group, Butterfly Back, Cellular Suspension, Clam, Commend, Compass, Connect, Cosm, DOT, Duracare, Durawrap, Eames Soft Pad, EnhancedAccess, Everywhere, Flex-Edge, Flute, Harmonic, Headway, Herman Miller Select, Hopsak 2, Intent, Iota, Jaw, Keyless Entry, Keyn Chair Group by Herman Miller, Latitude, Lino, Locale, Logic Mini, Logic Power Access Solutions, Live Platform, Loop, Lyris, Lyris 2, Made-to-Measure Storage, Mora, Multiscrim, Nelson, Nevi, Overlay, Pari, Pixelated Support, PostureFit SL, Prospect, Renew, Sense, Soft Pad, Stackable, Stackable Storage, Striad, Swoop, Tone, TriFlex, Twist, Ubi, Valor, Verus, Vista and Wireframe are among the trademarks of Herman Miller, Inc., and its owned subsidiaries.

SM Herman Miller Options is among the service marks of Herman Miller, Inc.

AAP™ is a trademark of Extron Electronics.

Alexander Girard® is a registered trademark of The Alexander Girard Estate.

Chemsur® is a registered trademark of Wilsonart International.

Corian® is a registered trademark of E. I. du Pont de Nemours and Company Corporation.

Crypton® is a registered trademark of Crypton, Inc.

DACRON® is a registered trademark of INVISTA S.a r.l.

Danzer® is a registered trademark of Danzer Holding AG.

Decora® is a registered trademark of Leviton Manufacturing Co., Inc.

Edelman® Leather is a registered trademark of Edelman Leather, Inc.

Extron® is a registered trademark of RGB Systems, Inc.

FENIX NTM® is a registered trademark of Arpa Industriale S.p.A.

FLEXNET™ is a trademark of Milliken & Company.

Floor Saver Glide® is a registered trademark of Carpin Manufacturing, Inc.

Geiger® is a registered trademark, and Bumper™, Saiba™, and Ward Bennett™ are trademarks, of Geiger International.

Goetz™ is a trademark of Mark W. Goetz.

Hang-It-All® is a registered trademark of Lucia Eames Demetrios, d.b.a. Eames Office.

Holophane® is a registered trademark of Holophane.

Ingeo™ is a trademark of Cargill Dow LLC.

iPad® is a registered trademark of Apple, Inc.

Leviton® is a registered trademark of Leviton Manufacturing Co., Inc.

LifeSize® is a registered trademark of LifeSize Communications, Inc.

Magis®, Bombo®, and Me Too® are registered trademarks of Magis S.p.A.

Microsoft® and Natural® Keyboard are registered trademarks of Microsoft Corporation.

Noguchi® and the Noguchi table configuration (trade dress) are registered trademarks, and Rudder Table™ is a trademark, of The Isamu Noguchi Foundation and Garden Museum.

Place Textiles® is a registered trademark of Place Textiles.

SuperSeat™ is a trademark of Dahti Seating, a division of ITW.