

SQUARE, ROUND AND MOBILE TABLE ASSEMBLY

TOOLS REQUIRED: 3/4" HEX SOCKET
RATCHET WRENCH
TORQUE WRENCH
#3 PHILLIPS SCREWDRIVER
(POWER SCREWDRIVER IS RECOMMENDED)

PROCEDURE:

NOTICE
Make sure fasteners are torqued to specified values.

1. INVERT TABLE TOP ON A CLEAN, PADDED SURFACE.
2. REMOVE TABLE BASE CASTING FROM TOP CASTING, IF ASSEMBLED, BY REMOVING SHORT SHIPPING BOLT AND WASHER. DISCARD CARDBOARD OR WOOD WASHER AND SHORT SHIPPING BOLT.
3. FOR TABLE TOP THAT DOES NOT HAVE TOP CASTING PRE-ATTACHED, CENTER TOP CASTING ON TABLE TOP. INSERT (4) SCREWS AND TIGHTEN.
4. THREAD JAM NUT COMPLETELY ONTO ONE END OF THREADED ROD.
5. INSERT ROD, JAM NUT DOWN, AND THREAD COMPLETELY INTO TOP CASTING. TIGHTEN JAM NUT AGAINST TOP CASTING. PLACE TUBE OVER ROD ONTO TOP CASTING.
6. FOR MOBILE TABLE ONLY, INSERT CASTERS INTO BASE.
7. FOR UNIVERSAL BASE ONLY-PLACE STEEL BUSHING OVER ROD INTO TUBE.
8. INVERT TABLE BASE CASTING, CASTERS/GLIDES UP, AND PLACE OVER TUBE, MAKING SURE THAT BASE CASTING LEGS ARE ALIGNED APPROXIMATELY WITH TOP CASTING ARMS.
9. ASSEMBLE WASHER AND LOCK WASHER ONTO THREADED ROD. TORQUE JAM NUT TO MINIMUM OF 40 FT-LBS.
10. PLACE TABLE IN UPRIGHT POSITION AND RETURN TO SERVICE.

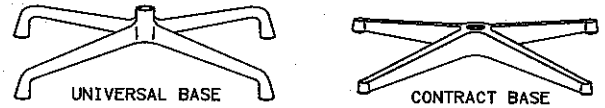

BASE TYPES

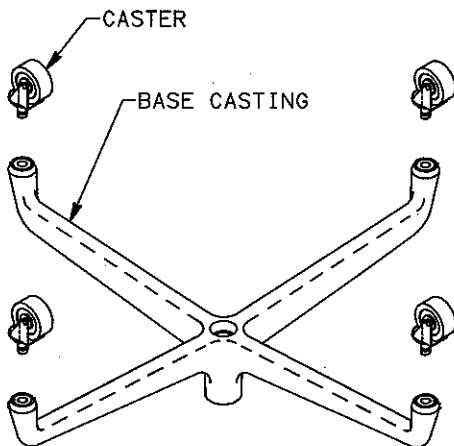
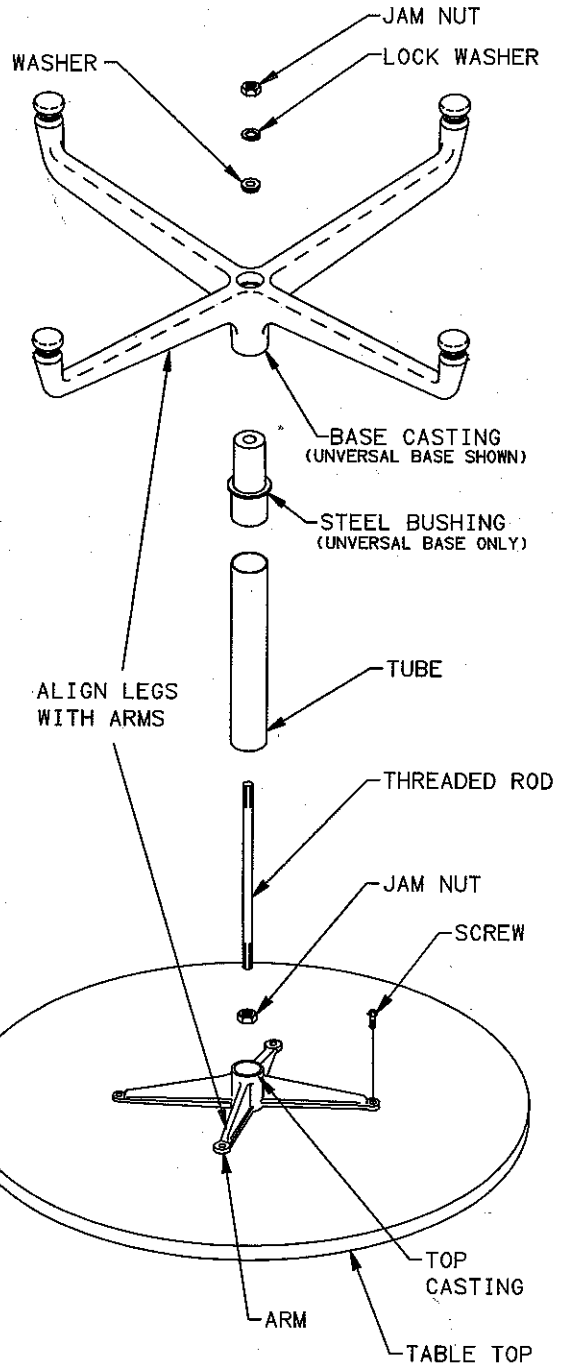

FOR MOBILE TABLE ONLY

108445 REV H