

Eames® Segmented-Base Tables  
Round Table  
ET122  
ET123  
ET124  
ET125

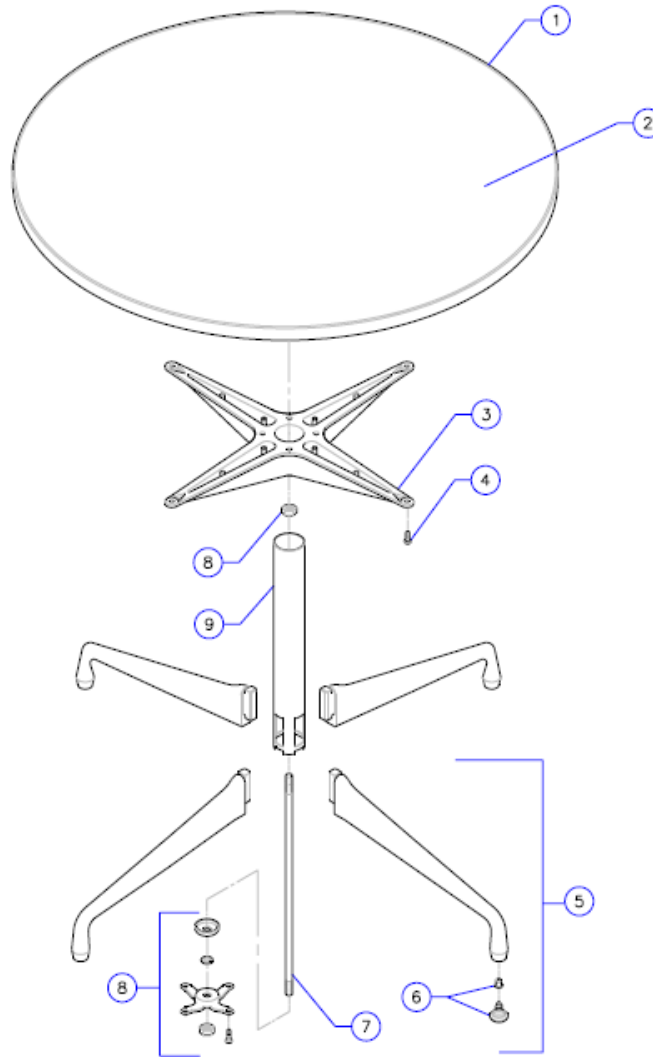

A few key points to assembly of these bases:

1. Tighten the threaded rod (#7) into the spider (#3) first
2. Make sure the legs are hooked firmly into the column before installing the hardware (#8)
3. Make sure the hardware (#8) is installed in the order shown. The four pronged "chicken foot" must be installed with the open cupped portion facing the floor.
4. All fasteners must be tight.

Here are all the available assembly instructions for the ET Eames Segmented Base Table. The following picture and assembly instructions are those that go out with the product. They are generic and only show a two column base not a single column but the assembly order is the same for both bases. The Service parts sheet above is a better representation of the assembly order.

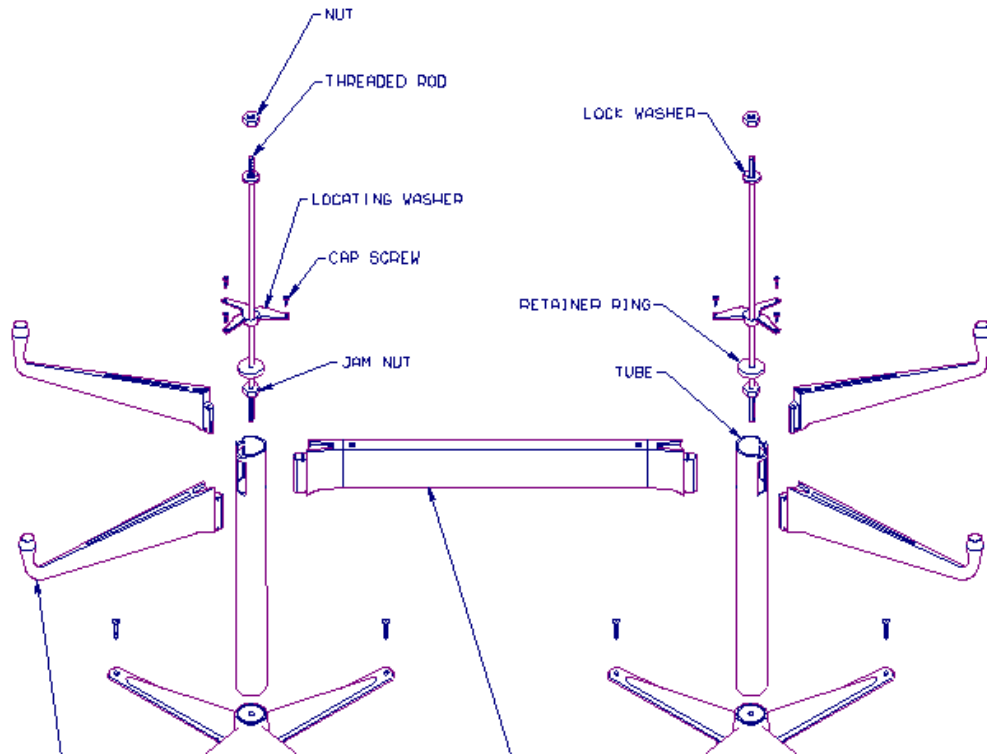

# TABLE ASSEMBLY

TOOLS REQUIRED: 3/4" SOCKET HEAD WRENCH  
1/4" ALLEN WRENCH  
#3 PHILLIPS SCREWDRIVER  
(POWER SCREWDRIVER IS RECOMMENDED)

PROCEDURE:

1. REMOVE PARTS FROM CARTON USING CARE TO AVOID DAMAGING TABLETOP. REMOVE CARDBOARD FILLERS AND DISCARD.
2. INVERT TABLE TOP ON A CLEAN PADDED SURFACE.
3. REMOVE SHIPPING RAIL, WHEN ATTACHED, BEFORE ATTACHING TOP CASTING(S).
4. POSITION TOP CASTING(S) ON TABLE TOP AS FOLLOWS:
  4. POSITION TOP CASTING(S) ON TABLE TOP AS FOLLOWS:
    - FOR TABLE TOP WITH PREDRILLED HOLES, ALIGN HOLES IN TOP CASTING(S) WITH HOLES IN TABLE TOP.
    - FOR ROUND TABLE TOP WITHOUT PREDRILLED HOLES, CENTER TOP CASTING ON TABLE TOP.
    - FOR OVAL OR RECTANGULAR TABLE TOP WITHOUT PREDRILLED HOLES, PLACE TOP CASTINGS ON TABLE TOP AS SHOWN USING SPECIFIED DIMENSIONS FOR INDIVIDUAL SIZES. SEE FIGURE 1 AND CHART 1.
  5. INSERT (4) SCREWS AND TIGHTEN. SEE FIGURE 2.
  6. REMOVE THREADED ROD AND TUBE FROM CARDBOARD CONTAINER.
  7. THREAD JAM NUT ON ONE END OF THREADED ROD UNTIL JAM NUT STOPS. SEE FIGURE 2.
  8. THREAD ROD END WITH JAM NUT ALL THE WAY INTO THE TOP CASTING. TIGHTEN JAM NUT AGAINST TOP CASTING. SEE FIGURE 2.



**A**

1  
(

-----

9. PLACE TUBE OVER ROD ONTO THE TOP CASTING. SEE FIGURE 2.
10. PLACE SPREADER ASSEMBLY INTO SLOT IN TUBES, WHEN APPLICABLE. SEE FIGURE 2.
11. INSERT LEGS INTO SLOTS IN THE TUBES AND PLACE RETAINER RING IN SLOT ON THE LEGS AND SPREADER ASSEMBLY. SEE FIGURE 2.

NOTE: RETAINER RING FITS INSIDE OF TUBE.

12. PLACE LOCATING WASHER OVER LEGS AND SPREADER ASSEMBLY AND FASTEN WITH CAP SCREWS. SEE FIGURE 2.
13. PLACE LOCK WASHER ON THREADED ROD. THREAD NUT ON ROD AND TIGHTEN. SEE FIGURE 2.

